

DEPARTMENT OF MINES AND ENERGY
SOUTH AUSTRALIA

REPORT OF INVESTIGATIONS

THE ENGINEERING GEOLOGY
OF THE LITTLE PARA
DAM SITE

W.R.P. BOUCAUT

AND

J.C. BEAL

Rept. Bk. No. 79/2
G.S. No. 6121
D.M. No. 846/74
Eng. No. 64/38

October, 1979

CONTENTS

SUMMARY

ACKNOWLEDGEMENT AND TERMS OF REFERENCE

PART I: INTRODUCTION, EARLY INVESTIGATION AND DAM DESIGN

Engineering Statement

Early Investigation

Site Assessment and Dam Design

PART II: MATERIAL TESTS

Introduction and Summary

Rock Tests

Soil Tests and Clay Mineralogy

PART III: DESIGN AND CONSTRUCTION

Geology, Dam Design & Construction

The Abutments

Grout Caps & Parapet Wall

The Grout Curtain

Outlet Structures

The Spillway

The Quarry

Main Access Road

PART IV: THE GROUTING PROGRAMME AND GROUT CURTAIN INVESTIGATION

Introduction

The Grouting Programme

Investigation of the Grout Curtain

Water pressure tests on the Grout Curtain

Discussion and Summary

PART V: SURVEILLANCE PROGRAMME AND PROJECT EVALUATION

REFERENCES

APPENDIX I: Report on Grouting and Water Pressure testing.

APPENDIX 2: Report on the Instrumentation of Little Para Dam.

APPENDIX 3: Report on Slope Stability Investigations.

APPENDIX 4: Summary of Material Tests.

APPENDIX 5: Reference Data.

LIST OF FIGURES

<u>Fig. No.</u>	<u>Title</u>	<u>Drawing No.</u>
Fig. 1	Little Para Dam, South Australia. Locality Map.	S12319
Fig. 2	Little Para Reservoir and Mannum Pipeline - Regional Locality Map.	74-903
Fig. 3	Little Para Rockfill Dam, Outlet Tower and Reservoir.	
Fig. 4	Chosen Dam Site. Looking Downstream.	
Fig. 5	Regional Geology Map.	S13102
Fig. 6	Stratigraphic Column and Construction Features.	S13399
Fig. 7	Location of Dam, Spillway and Quarry in Relation to major Geological Features.	77-770
Fig. 8	Grout Cap Alignment Geological Cross Section.	78-402
Fig. 9	Grout Cap Alignment. Geological Plan.	73-929
Fig. 10	The Left Abutment and Outlet Duct.	
Fig. 11	The Right Abutment.	
Fig. 12	Dam cross-section showing Rockfill zones.	S12070
Fig. 13	Cavity exposed in the Right Abutment Inspection trench.	
Fig. 14	Prediction of Piping failure in Earth Dams.	S13400
Fig. 15	Correlation of field performance of Earth Dams in Australia.	S13401
Fig. 16	Embankment. Zone 1, Zone 2 and Zone 6.	
Fig. 17	Embankment. Sluicing of Rockfill.	
Fig. 18	Treatment of geological features during dam construction.	77-475
Fig. 19	Location of Grout Cap Blocks and outcrop of completely weathered dolomitic siltstone, right abutment.	78-385

Fig. 20	Excavation of dolomitic siltstone and location of filter trenches.	76-688
Fig. 21	Left Bank Grout Cap Excavation.	
Fig. 22	Right Bank Grout Cap Excavation.	
Fig. 23	Outlet Tower Foundation Investigation. Geological Cross Section.	S13409
Fig. 24	Left Abutment and Outlet Duct.	
Fig. 25	Control House Foundation Investigation - Geological Cross Section.	S13410
Fig. 26	Seismic Refraction Survey. Spillway Discharge area.	75-462
Fig. 27	Spillway Geological Log.	76-929
Fig. 28	Spillway Ski Jump - Channel Wall.	
Fig. 29	Quarry and Water Treatment Works.	
Fig. 30	Right Bank Grout Curtain. Self Potential and Point Resistance readings.	76-756
Fig. 31	Water Pressure Testing on Grout Cap Block 'S' with Rhodamine B Dye.	
Fig. 32	Right Bank Grout Curtain. Isotopic Grouting. Scintillometer recordings.	76-757
Fig. 33	Summary of Water Connections during water pressure Tests (Plan).	S12684
Fig. 34	Summary of Grout connections during Isotopic Grouting Tests (Plan).	S12685
Fig. 35	Geiger Probe readings on grout hole SP116.	S12682
Fig. 36	Grout summary sheet SP116 Stage. 3. (Plan and vertical section).	77-473
Fig. 37	Water test summary sheet. SP116 Stage. 1. (Plan and vertical section).	77-472
Fig. 38	Surveillance Programme. Observation Wells and Groundwater Contours.	79-59

APPENDIX 1

Fig. 39	Downstage grouting without packer.	
Fig. 40	Drilling sequence for downstage grouting.	
Fig. 41	Right Abutment Drilling and Grouting Procedures.	
Fig. 42	Grout take Summary - Geological Cross Section.	77-1001
Fig. 43	Grout~take Summary - Plan.	77-474
Fig. 44	Lugeon Tests - check hole on DH 24.	S13885
Fig. 45	Lugeon Test calculation sheet.	S13886

APPENDIX 2

Fig. 46	Arrangement of Instrumentation.	76-729
Fig. 47	Stress distribution in Outlet Duct reinforcement.	S13403
Fig. 48	Embankment Settlement verses time.	S13402
Fig. 49	Stress on the Outlet Duct during embankment construction.	S13404
Fig. 50	Embankment settlement results of Hydraulic Gauge No. 2.	S13405

APPENDIX 3

Fig. 51,52,53,54:	Shear Box Test Results.	
Fig. 55	Quarry: Stereogram of field data prior to excavation.	S12763
Fig. 56	Quarry: Stereogram of field data after excavation.	S12762
Fig. 57	Quarry: Stereographic representation of Fracture Poles, Fracture planes and Quarry Batter Planes.	S12761
Fig. 58	Quarry: Regime locations	S12760
Fig. 59	Quarry: Stereographic failure analysis (EASTERN REGIME).	S12764
Fig. 60	Quarry: Stereographic failure analysis (CENTRAL REGIME).	S12765
Fig. 61	Quarry: Stereographic failure analysis (WESTERN REGIME).	S12766

Fig. 62	Stability assessment; Quarry Profile.	77-595
Fig. 63	Spillway Fracture Survey.	S13408
APPENDIX 4		
Fig. 64	Mechanical Analysis of soil road fill.	S12069
Fig. 65	Mechanical Analysis of weathered dolomitic siltstone. Right Abutment Inspection trench	S12068
Fig. 66	Mechanical Analysis of weathered dolomitic siltstone. Parapet wall and 'Block E', left bank grout cap.	S12067
Fig. 67	Ring Density Test and Zone 1 grading envelope.	S12680

SUMMARY

Geological investigations proved a suitable site for a 53 m high decked rockfill dam. The reservoir has a capacity of 2 100 megalitres and is built in the Little Para River, 22 km northeast of Adelaide, South Australia. Also included in the investigations are a combined quarry and water treatment works site and a spillway and spillway discharge site. The reservoir acts as a balancing storage for Murray River water and helps existing reservoirs to cope with increasing summertime demands.

The dam is founded on quartzite and dolomitic siltstone. The presence of dispersive clay in discontinuous weathered dolomitic siltstone seams in the dam foundation, necessitated establishment of an effective 21 m deep grout curtain. This curtain was checked using point resistivity, self potential and isotopic grout methods and was proved satisfactory. Isotopic grout in conjunction with a geiger probe proved the most successful method of checking the location of grouted strata. Apart from an isolated area on the right bank grout curtain which gave losses of up to 20 lugeons, water pressure testing of the completed grout curtain gave overall lugeon values of 4 to 7.

Slope stability analyses carried out over the spillway and quarry batters indicate stable rock mass conditions although falls of individual blocks are to be expected. The quarry berms will provide suitable foundations for the water treatment works.

Post-construction surveillance of the dam includes measurements of seepage values at a downstream discharge weir and groundwater level measurements in two observation bores placed adjacent to the downstream toe of the dam. No unexpected changes have yet been recorded. Total discharge was initially about 1.0 litres per minute, at 15 m head of water, mainly from springs which existed beneath the embankment prior to the construction of the dam.

Maximum total discharge measurements (Sept. 1979) taken with 37 metres of water in the reservoir indicate a total discharge of 10 litres/sec.

Instrumentation showed early settlement during construction in the lower third of the embankment of 500 mm caused by insufficient saturation of the fill during compaction. Total post construction settlement at January 1979 was 20 mm. The maximum measured pressure of the embankment upon the outlet duct is 970 MPa which is within the design limits of the duct.

ACKNOWLEDGEMENT AND TERMS OF REFERENCE

The Engineering and Water Supply Department has co-operated in the compilation of this report by making available all useful data collected during the investigation, design and construction stages of the Little Para Dam Project.

The Department of Mines and Energy provided a full time resident site geologist who reported on a daily basis to the resident site engineer. The resident geologist relied heavily on the experience of the site engineer and the advice provided by the Dam Project Committee.

During all stages of dam design and construction progress of the Little Para Dam Project was supervised by members of the Dam Project Committee. Permanent members of the Committee included from the Engineering and Water Supply Department, Engineer for Construction; Engineer for Design; Supervising Designing Engineer; Engineer for Water Supply; Senior Resident Engineer by invitation; and the Chief Geologist from the Department of Mines and Energy.

The Committee were called together whenever any change was proposed to the original designed dam and its specified method of construction. It was also required to confirm the suitability of all foundations. Other involved persons were also invited, as required, to attend the Committee meetings.

INTRODUCTION, EARLY INVESTIGATION AND DAM DESIGN

ENGINEERING STATEMENT

The State of South Australia has always been heavily dependant upon the River Murray for a continued water supply. This supply is augmented by seven reservoirs founded on river systems largely confined within a 50 km radius from Adelaide. (Figures 1 and 2). A comparison between Little Para Dam and two other South Australian Dams (Kangaroo Creek Dam and Myponga Dam) is shown in Table 1.

By 1979 it was calculated that the water supply to the Northern Plains area of Adelaide would be inadequate to meet demands and therefore to help meet these a concrete faced rock fill dam on the Little Para River located 22 km northeast of Adelaide and approximately 7 km due east of the City of Salisbury has been constructed by the Engineering and Water Supply Department of South Australia (Figure 3).

Apart from impounding natural waters the reservoir may receive River Murray water from a branch off the existing Mannum-Adelaide pipeline. Included in the design is a water treatment works sited 300 metres downstream from the dam.

Site work began on 18th April, 1974. Storage of water commenced in August, 1977. A summary of the Construction Schedule for Little Para Dam is shown in Table 2.

The principal statistics of the dam and reservoir are:

Height of dam above stream bed	53 metres
Crest length of dam	255 metres
Maximum width at base of dam	140 metres
Spillway crest length	71 metres
Reservoir capacity	21 000 megalitres
Reservoir waterspread	125 hectares
Elevation of reservoir at Full Supply Level	EL 149.30

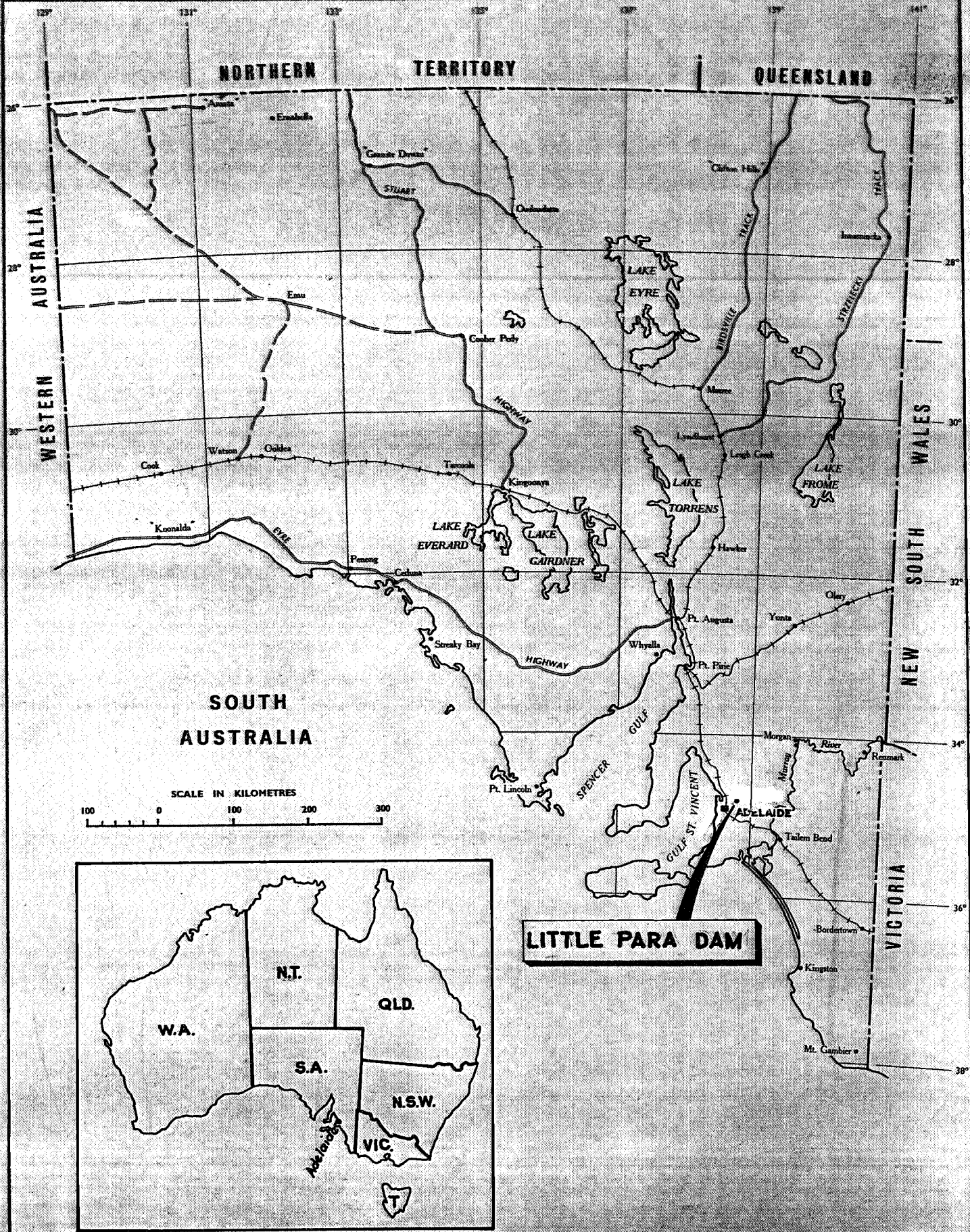


FIG. 1

DEPARTMENT OF MINES AND ENERGY
SOUTH AUSTRALIA

**LITTLE PARA DAM
LOCALITY MAP**

Compiled.	J.C.B.
Drn. L.C.	Ckd.

Date:	AUGUST '76
Drp. No.	S12319

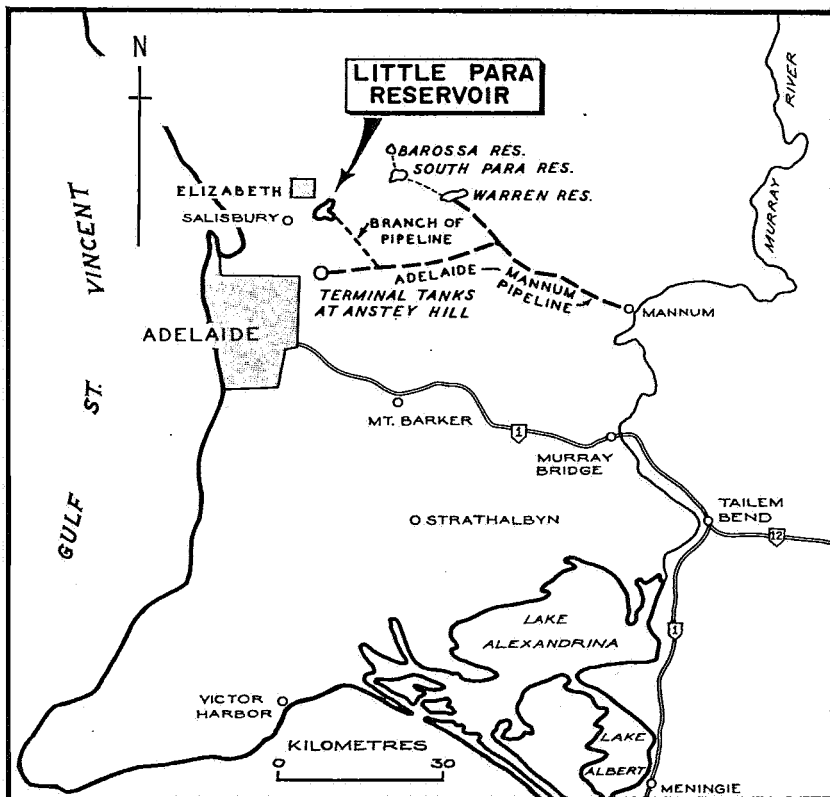
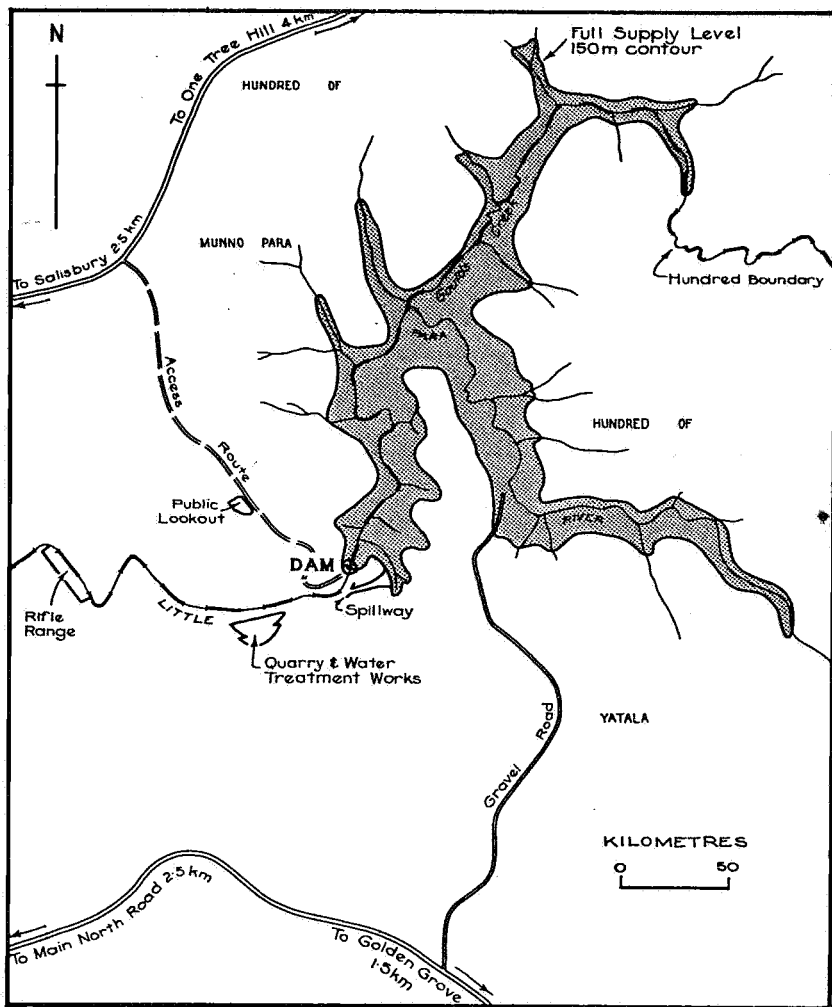


FIG. 2

DEPARTMENT OF MINES AND ENERGY
SOUTH AUSTRALIA

SCALE: —

LITTLE PARA RESERVOIR
MANNUM ADELAIDE PIPELINE
REGIONAL LOCALITY MAP

DATE: 25-10-79

PLAN NUMBER
S14393

COMPILED: J.C. Beal

DRN N.S. CKD

1064



SLIDE NO. 13609 - Jan. 1978
LITTLE PARA ROCK FILL DAM,
TOWER AND RESERVOIR.
First filling of the
reservoir.

FIG. 3

Area of catchment	80 square kilometres
Area of Reservoir Reserve	1 300 hectares (approx)

For most of the year the reservoir will be less than full in its main role as a balancing storage for River Murray water from the Mannum-Adelaide Pipeline. This factor will, of course, greatly increase the flood control capability of the dam.

Reservoir discharge, during periods of high natural recharge, can be regulated by flood control measures incorporated into the design of the dam.

These measures consist of a spillway and a 1 500 mm outlet pipe through the base of the dam to the river, bifurcating at the downstream end into two 750 mm pipes, each controlled by a fixed cone energy dispersion regulating valve. Constructed into the spillway lip are two notches with one 0.8 metres deep and the other 0.52 metres, each 1.5 metres wide. For water supply operations the reservoir is designed to be at full supply level when the water level reaches the bottom of the lower notch. A further overall water depth of 0.8 metres is thus provided for the pondage of floodwaters in the reservoir. The discharge of this pondage will be regulated by the notch sizes, which will restrict the outflow, and reduce the flood peak. To provide additional pondage when the likelihood of an extreme flood is apparent, or to restore the flood control capacity after the spillway has been overtopped by an unexpected extreme flood, the river outlet valves can be used to lower the level of the reservoir at a controlled rate which will be well within the capacity of the lower channels of Little Para River in the northern suburbs of Salisbury and Elizabeth.

TABLE I
COMPARISON OF LITTLE PARA DAM
 WITH
KANGAROO CREEK DAM AND MYPONGA DAM

	LITTLE PARA ROCKFILL 1978	KANGAROO CREEK ROCKFILL 1969	MYPONGA CONCRETE 1957
Capacity	21 000 megalitres	24 400 megalitres	27 300 megalitres
Years of Const- ruction	1974-77	1966-69	1958-62
Actual Cost (includes land acquisition)	\$11.0 million	\$5.3 million	\$6.3 million
Cost on December 1973 basis	\$5.6 million	\$7.9 million	\$12.0 million
Cost per 1 000 megalitres on October 1973 basis	\$267 000	\$324 000	\$440 000
Height above Stream Bed	53 metres	60.95 metres	47.55 metres
Quantity of Rockfill in the Dam	288 000 c.metres	354 000 c.metres	
Quantity of Concrete in Dam, Spillway, Tower etc.	14 000 c.metres	17 860 c.metres	57 380 c.metres
Area of Waterspread	126 hectares	130 hectares	260 hectares
El. of Stream Bed	El. 100	El. 183.947	El. 156.659
El. of Full Supply level	El. 149.30	El. 241.859	El. 211.379
El. of Top of Dam	El. 153	El. 244.907	El. 213.208
Length of Crest	225 metres	131 metres	226 metres
Catchment Area	82.5 sq. kilom.	290 sq. kilom. (shared with Mill- brook reservoir)	116 sq. kilom.

TABLE 2

SCHEDULE OF CONSTRUCTION OPERATIONS

		1974	1975	1976	1977	1978
GROUT CAPS AND ABUTMENT EXCAVATION	Access Roads. Works Area Services Concrete Batch Plant	90% Complete 20% Excavated Telephone Site Selected	Completed Completed All Services Connected Completed	Extended to down Stream toe of dam		
GROUT CAPS AND GROUT CURTAIN, POURING, DRILLING AND GROUTING	Excavation Left Grout Cap Excavation Right Grout Cap Clean-up Left Abutment Clean-up Right Abutment Grout Curtain	Commenced & completed Commenced Cleaned Up As	Embankment Placed Completed Drilling & grouting comm.		Completed and tested	
OUTLET TOWER	Tower Base Excavation Blanket and Curtain Grouting Beneath Tower Tension Bars Beneath Tower Tower Floor Walls	Commenced & completed Commenced & completed 53 Bars Placed	Bars tensioned Floor completed Wall commenced	Walls completed to EL111.5 rest Contract	Tower completed mid 1977	
OUTLET DUCT AND CONTROL HOUSE	Duct Floor Duct Arch Control House	Excavation Comm & Comp.	Floor Extend to control House Commenced	Completed Wing walls formed		Completed
RIVER DIVERSION AND CAUSEWAY	Temporary Diversion Tunnel Coffer Dam Permanent Diversion Tunnel Permanent Causeway	Commenced & completed Completed Commenced	Commenced	Completed Completed		
SPILLWAY	Excavation and Concrete Anchoring Spillway Lip labyrinth	Overburden stripped	Channel Exc. Comp. First Rockfill Nov.	Flip Bucket Excavation complete 80% rockfill placed	} Completed	
EMBANKMENT	Placement of Rockfill			Commenced	Zones 1,2,3,4,6.	Zone 5 completed
CONCRETE FACE AND PARAPET WALL				Commenced	Dec. completed	
QUARRY AND WATER TREATMENT WORKS	Haul Roads Excavation Design of Water Works Construction of Water Works					Investigation of stability not commenced main berm & batter.
MAIN OUTLET PIPE					Commenced	Completed March.

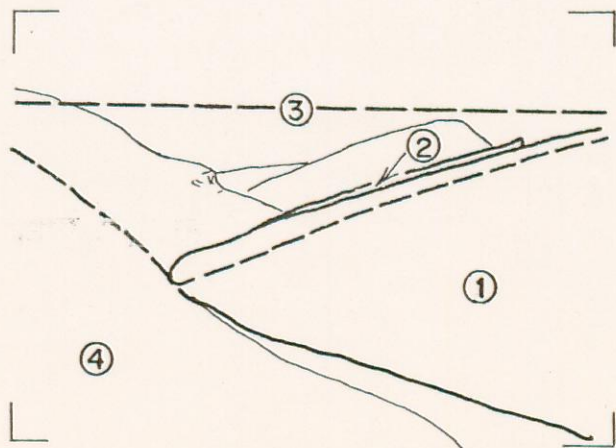
PARLIAMENTARY APPROVAL TO BUILD THE DAM AND WATER TREATMENT WORKS MAY 1974

SITE WORK COMMENCED APRIL 1974

RESERVOIR IN OPERATION AUGUST 1977

ROCKFILL DAM AND PIPELINES COMPLETED MARCH 1978

SUPPLIED WITH PUMPED MURRAY RIVER WATER JUNE - NOVEMBER 1978



NEGATIVE NO. 13066 - July 1973
CHOSEN DAM SITE

1. Quartzite stratum (UNIT 12)
forming dip slope on right
abutment.
2. Spoil from exploration trench.
3. Dam axis.
4. Dolomitic siltstone, left
abutment.

FIG. 4

EARLY INVESTIGATION

Between 1959 and 1961 several rivers to the north of Adelaide were briefly investigated for potential dam sites by the Department of Mines and Energy, and different dam types discussed with the Engineering and Water Supply Department. In 1964 it was decided to restrict investigations to the Little Para River, and the Department of Mines and Energy carried out a hydrogeological survey of the Little Para River; investigating its role in the recharge of aquifers downstream of the reservoir and lying beneath the North Adelaide Plains (Kingstone, D., Shepherd R.G.).

By the end of 1972 from five alternative sites, a rockfill dam site was chosen (Figure 4) on the basis of geologically suitable foundations and abutments.

A decision against building a concrete gravity dam on this site was influenced by the unsuitable topography of the abutments, the identification of a shear zone traversing the left abutment and the presence of cavities in the rock exposed in an inspection trench on the right abutment. These cavities and the presence of associated seams of completely weathered dolomitic siltstone* proved foundations unacceptable for a concrete gravity dam.

In 1973-1974 the Engineering and Water Supply Department carried out an ecological survey of the water catchment area and the Little Para River which concluded that although the catchment area had been extensively modified by man the river has remained little changed and should be left intact as much as possible during the construction of the dam.

Detailed geological investigation of the site commenced in 1973. This included geological mapping, diamond drilling, geophysical surveys and high pressure water sluicing along the grout cap alignments. Suitable sitings for the spillway and quarry were investigated.

* See Appendix 5 for definition of descriptive terms.

ECOLOGICAL SURVEY

A limited ecological survey of the Little Para River catchment by the Engineering and Water Supply Department (Miller D.J.) was undertaken to outline the biology in the Little Para Reservoir district.

Stream flows in the Little Para River catchment are extremely variable both on an annual and daily basis. The median average rainfall is between 450 mm and 700 mm.

With the exception of some 650 hectares along the eastern boundary of the watershed the plant associations have been extensively and irreversibly modified by man's activity. In the region of the proposed reservoir, modification, due to clearing of certain Eucalypt associations, has led to the local extinction of all but approximately twenty-five of the native plants and their replacement by aliens and noxious weeds. Of these twenty-five species, ten are confined to the stream communities and five to the refuge habitats of a quartzite scarp (Fig. 7).

The stream communities differ markedly from the terrestrial communities in that little modification due to human occupation seems to have occurred. In the stream below the dam site a diverse aquatic fauna exists, apparently undisturbed by introduced fauna. It is from this region that the first occurrence of a particular species of psephenid beetle larvae in South Australia was established during the course of the survey.

The recommendations arising from the study are concerned primarily with protection of water quality and the preservation of ecologically significant areas.

Requirements for the management of the reserve, precautions to be taken during the construction and operation of the dam and recommendations for further studies are as follows:-

1. Afforestation of the reservoir reserve over a ten year period.
2. A programme of seed collection from Eucalypts species in the district and their germination for an afforestation programme.
3. Rejuvenation of two small swamp areas downstream of the dam.
4. Formulation of a noxious weed control programme.
5. Selection of the point of discharge of supplementary Murray River water into the Little Para River should have regard for erosion and siltation effects. These affects should be further minimised by the use of baffle weirs and suitable biological communities.
6. Protection of the downstream aquatic communities by the maintenance of flow in the Little Para River and by the careful siting of ancillary structures to the dam. Protection during construction, by diversions of stream flow around areas likely to contribute silt downstream and by exclusion from the stream of water from sluicing operations.
7. Retention of as many quartzite outcrops as possible.
8. Investigation of the Little Para River estuary to determine the effect of winter discharge on the mangrove communities.

HYDROLOGICAL SURVEY

An investigation of the aquifers of the Northern Adelaide Plains was required to assess the affect of impounding water by the Little Para Reservoir on the intake to the groundwater of the aquifers.

For approximately five years from 1968 to 1973 flow measurements have been made at several points along the Little Para River and, in addition, groundwater levels have been taken

on a monthly basis from observation bores entering the Northern Adelaide Plains aquifers.

In the Northern Adelaide Plains growers rely on the continued use of groundwater for irrigation of their market gardens. Had the hydrological survey shown that building the dam would dangerously affect the quantity of groundwater available for recharge of the aquifers, then serious consideration would have been given to abandoning the Little Para Dam project.

Hydrographs of bores adjacent to the Little Para River show that it is an important source of recharge to aquifers of the Salisbury area. Recharge takes place via shallow aquifers and then to deeper aquifers through semi-confining beds and possibly through the Para Fault Zone (Figure 5).

On the basis of change in storage of the shallow aquifers, average annual recharge is estimated to be 2 350 megalitres. It has been estimated on the basis of stream flow measurements in the Little Para River, (Kingstone, D., and Shepherd, R.G., 1973), that a total annual flow below the dam site of 3 320 megalitres is required to maintain the status quo, the difference being the water lost by evaporation and transpiration.

This requirement of 3 320 megalitres, will be met as far as is practicable by discharging water into the stream from the reservoir, with regard being given to upstream inflows and water running out to sea at the river's mouth.

Urban and rural run-off entering the Little Para River below the proposed dam is estimated to be 1 000 megalitres per year of which 600 megalitres may be conserved by appropriate works. If this were done then the quantity which must be released from the dam could be reduced to 2 700 megalitres per year.

SITE GEOLOGY

The dam is located on rocks of the Adelaide System (Burra Group) of Proterozoic Age (Figure 5), with a regional strike of 005° and dip 25° - 30° E.

The geological sequence in the vicinity of the dam site is interbedded quartzite (beds up to 12 metres thick) and dolomitic siltstone beds (up to 80 metres thick) (Figure 6).

The thickest quartzite stratum (Unit 12) is 12-15 metres thick, the lower 3 to 5 metres grading into the underlying dolomitic siltstone, with thin interbeds of quartzite and dolomitic siltstone. This gradational contact between two major rock types has its own weathering and grouting characteristics and is referred to as: transitional strata.

At the dam site the geology has controlled the formation of an asymmetric valley. On the left bank of the river the dolomitic siltstone forms a steep hillside with a prominent cliff at river level where the 12 metre thick quartzite bed (Unit 12) outcrops. On the right bank this same quartzite unit forms a dip slope hillside and is the main foundation for the rockfill dam.

Regional folding is observed downstream of the dam site, where quartzite beds are folded into shallow anticlines and synclines. However, the less competent dolomitic siltstone adjacent to these folds only exhibit multiple low angled shearing, frequently associated with lens shaped vuggy quartz veins. Unlike the quartzite the siltstone is fissile, splitting along a well formed cleavage which departs from the original bedding plan by only two or three degrees. Shearing commonly follows the cleavage planes but two shear zones, the major tectonic features in the area of the dam site, cut across the cleavage at approx. 45° .

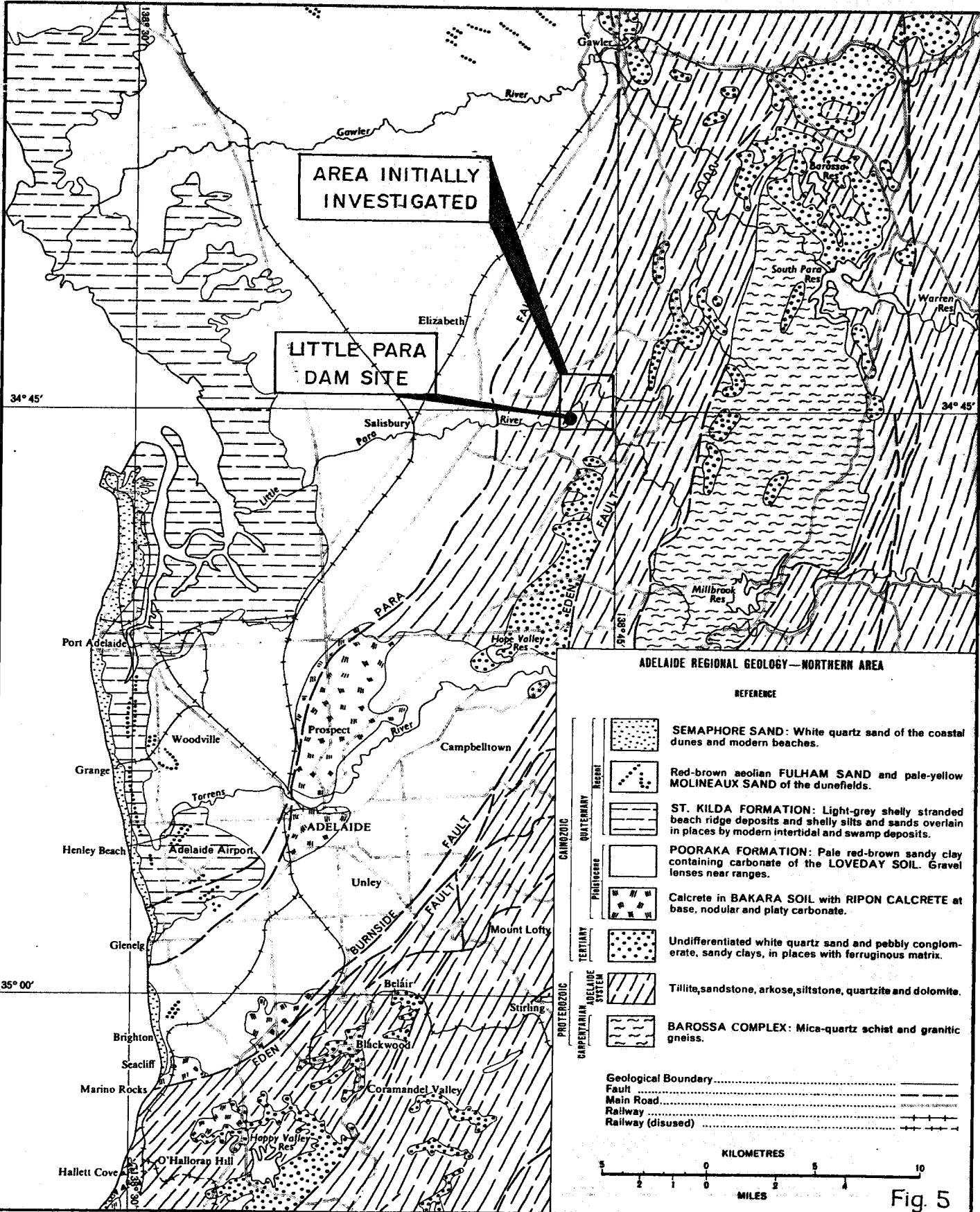


Fig. 5

ENGINEERING GEOLOGY SECTION	DEPARTMENT OF MINES—SOUTH AUSTRALIA	Scale: 1:250 000
Compiled: <i>J.C. Beal</i>	<h1>LITTLE PARA DAM SITE</h1> <h2>LOCATION AND REGIONAL GEOLOGY</h2>	Date: <i>24.10.77</i>
Drn. <i>J.W.W.</i> Ckd.		Drg. No. SI3102
Geology from Adelaide and Barker 1:250 000 Geological Atlas Series		

1126

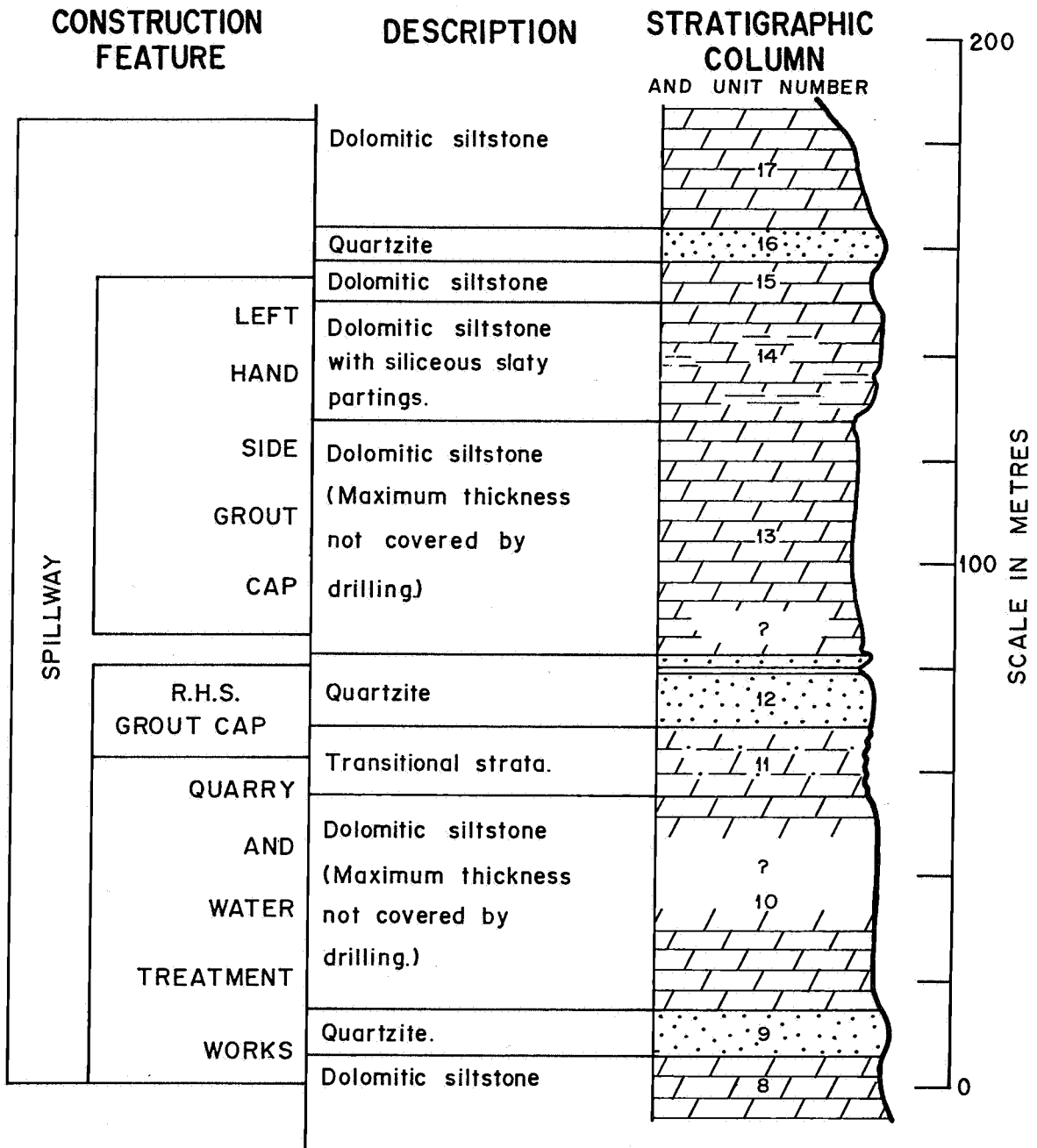


FIG. 6

		DEPARTMENT OF MINES AND ENERGY SOUTH AUSTRALIA	SCALE Diagrammatic
COMPILED: J.C.Beal.		LITTLE PARA DAM STRATIGRAPHIC COLUMN AND CONSTRUCTION FEATURES	DATE 8-5-78
DRN: G.J.T.	CKD:		PLAN NUMBER
			S13399

6711

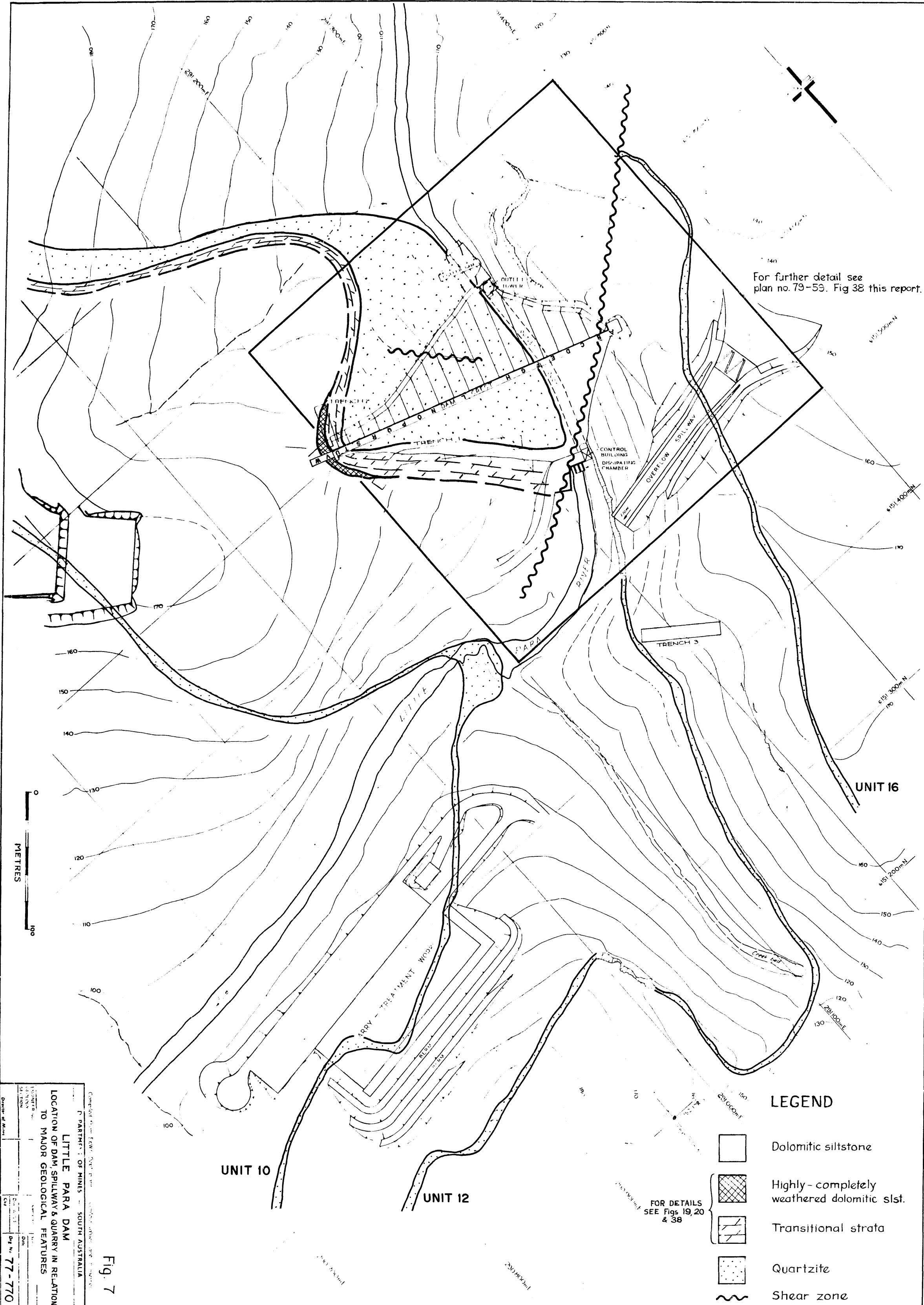
One of these shear zones runs from the bottom of the left bank hillside to the top striking at 045° and dips approximately 50° eastwards (Fig. 10). The quartzite cliff in the left bank abruptly terminates at river level against the shear zone. (Figure 7). The zone is probably related to transverse faulting initiated during Palaeozoic times. Some of these early faults have been re-activated during and since the Tertiary period, but there is no evidence of this later movement on the shear zone under discussion, the zone is tight and dry and without clay development.

The presence of a second shear zone, almost vertical only became evident during clean up of the right abutment (Figure 7). Although there is no surface evidence, downstream projection of this second shear zone would meet the first zone, described above, at about creek level, beneath the Control House foundations. Excavation of these foundations exposed no evidence of the two zones.

The dominant joint directions for both rock types fall into three main groups:- 025° , 080° , 120° . The joints are vertical to 70° dipping north and south but more frequently, northwards. The joints intersect to form large blocks in the quartzite (up to $2.0 \times 1.0 \text{ m} \times 1.0 \text{ m}$) and smaller blocks in the dolomitic siltstone (up to $1.0 \text{ m} \times 0.05 \text{ m} \times 0.03 \text{ m}$).






Small hillside cavities were exposed in dolomitic siltstone close to the axis of the dam at the top of the right bank hillside. Completely weathered seams of dolomitic siltstone, up to 100-500 mm thick, occur in the left abutment.

The zone of saturation and aeration of successive groundwater tables in the right abutment has formed a highly weathered zone of varying thickness in the dolomitic siltstone.



For further detail see plan no. 79-59. Fig 38 this report.

LEGEND

-  Dolomitic siltstone
-  Highly-completely weathered dolomitic slt.
-  Transitional strata
-  Quartzite
-  Shear zone

FOR DETAILS SEE Figs 19, 20 & 38

Completed under E.A.W. Dept. of Mines, South Australia
 LITTLE PARA DAM
 LOCATION OF DAM, SPILLWAY & QUARRY IN RELATION
 TO MAJOR GEOLOGICAL FEATURES

Scale: 1:50,000
 Date: 1977
 Drawing No: 77-770

Fig. 7

The zone is 3.0 m thick where it outcrops at the top of the right abutment gradually thinning downhill. Section and plan of the geology of the dam site along the grout cap alignment is shown in Figures 8 & 9 respectively.

The criteria used for definition of rock terms are those in current use in the Engineering Division of the Department of Mines and Energy (see Appendix 5). The scale of weathering grades of a rock mass is diagnosed by visual (colour) change and loss of original rock strength and rock fabric compared to other systems (Dearman 1976) which use visual (colour) change and the ratio of rock to soil and breakdown of rock fabric.

Consideration was given during the early geological appraisal of the dam site to assessing the rock by giving values to parameters which describe rock strength and rock weathering (Burgess 1975) but this was abandoned because there were only two rock types and the condition of these could be easily assessed using current criteria already familiar to the site engineers.

SITE ASSESSMENT AND DAM DESIGN

A summary of the major geological investigations is given in Table 3.

THE RESERVOIR

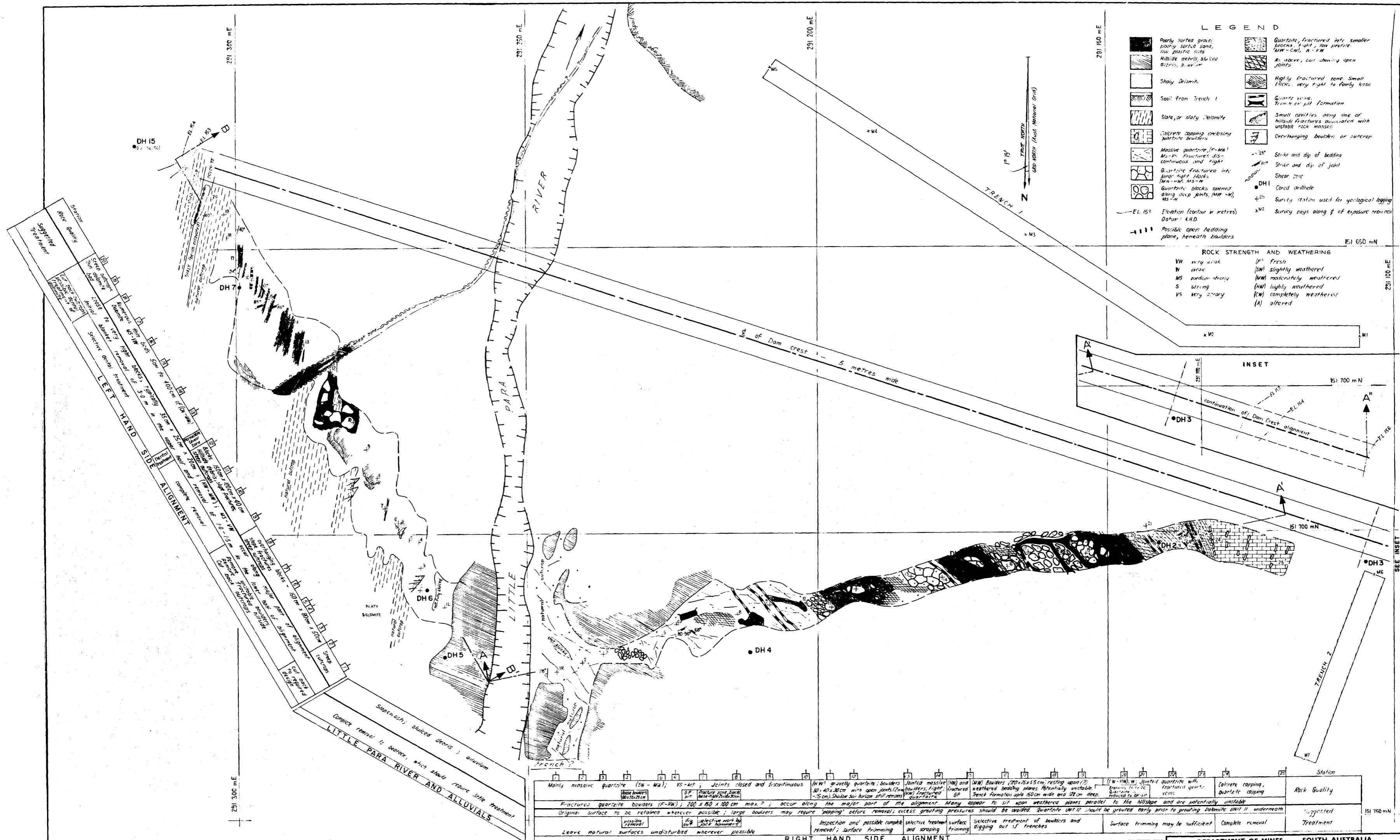
Mapping of the rim geology showed no areas of potential leakage and any of the five dam sites initially chosen for investigation would have impounded water within a watertight reservoir. It was therefore not necessary to modify in any way the natural state of the reservoir site.

THE DAM SITE

The building of a concrete arch dam across the Little Para River at the present site was originally considered but soon dismissed owing to the obvious poor rock quality of the abutments.

TABLE 3. LITTLE PARA RESERVOIR - SUMMARY OF INVESTIGATION

	ITEM INVESTIGATED	DESCRIPTION	SOLUTION ADOPTED	
RESERVOIR AND RIVER	1. Rim geology.	GEOLOGY: Regional mapping of reservoir area	No leakage anticipated.	
	2. Siltation of reservoir at Murray River Water Pipeline outlet.	ECOLOGY: Low level concrete 'Barrage' to hold silt and encourage growth of plant life.	Recommendation accepted.	
	3. Siltation of river downstream of dam site.	Detrimental to fauna and flora in perennial rock pools and swamp habitats.	River will by-pass construction work via Coffey Dam and outlet duct; silty water prior to this inevitable.	
	4. Discharge downstream of cold de-oxygenated dam water.	Suggested standing pool to allow outlet water to warm and oxygenate.	Reservoir Water to be taken from high outlet tower level. Standing pool not necessary.	
	5. Preservation of native fauna and flora and aesthetic appeal of reservoir area.	Some rare eucalyptus and a rare species of beetle discovered. Suggested seed collection and germination programme.	Planting of reservoir reserve; limiting excavation of quartzite scarp habitats; rehabilitation of excavated faces; avoid siltation of beetle rock pool habitat.	
	6. Recharge of North Adelaide Plains aquifers.	HYDROGEOLOGY: Four year borehole and stream gauge study along Little Para River. 3,320 Ml per year recommended.	Recommended discharge figures accepted.	
DAM SITE - FOUNDATIONS	7. Unstable cliff boulders above outlet pipe alignment.	GEOLOGY: Removal or rock bolting of boulders or protection of pipe suggested.	Resiting of pipeline to filter works not possible, opposite bank to be used as access road.	
	8. Uncertain foundation conditions beneath downstream toe of dam and control house.	GEOPHYSICAL: Seismic refraction survey shows bedrock at max. 5 m with possible cavities. Presence of shear zone may be indicated.	Bedrock conditions remain uncertain. Complete excavation of alluvials recommended.	
	9. Artesian aquifer beneath dam site intercepted in one borehole.		Insignificant compared to water head of reservoir.	
	10. Completely weathered dolomite.	MINERALOGY: Clays examined for expansive properties.	Tests show dominant quantities of Montmorillonite. Specific gravity of weathered dolomite : 1.74.	
	<u>Left Bank</u>			
DAM SITE - ABUTMENTS AND GROUT CAP ALIGNMENTS	11. Grout cap - hillside fractures	GEOLOGY: High pressure water sluicing reveals hillside fractures. (Tectonic or pressure relief fractures?).	Produces unstable hillside rock masses and complete removal advised.	
	12. Grout cap - highly weathered phyllitic dolomite and sheared bedding planes.	Occurs parallel to bedding of strata in upper half of grout cap.	Removal of upper 3.0 metres along grout cap advised plus selective dental treatment where necessary.	
	13. Alignment of shear zone behind left bank. Possible hillside failure.	GEOPHYSICAL: Very low frequency (VLF) traverse indicates surface expression of shear zone.	Shear zone exhibits properties of wet tabular body. Zone considered a possible leakage path. Dental treatment where zone crosses grout cap advised.	
		<u>Right Bank</u>		
	14. Grout cap open joints in quartzite.	GEOLOGY: In upper half of grout cap sluicing reveals trenchlike infilled joints and loose quartzite boulders.	Selective cleaning of open joints with jack hammers advised and removal of loose boulders.	
	15. Weathering of strata in upper third of grout cap to a depth of 4.0 m.	MAPPING: Grout cap shows weathered dolomite beneath calcrete capping.	Complete excavation of upper part of grout cap down to 3.0 m.	
	16. Possible cavities beneath quartzite.	Drillhole gives core loss beneath base of quartzite at 11.5 m from surface.	Inspection by borehole TV camera suggests cavity. Downstage grouting techniques for grout curtain advised.	
17. Grouting Procedure.	Above data must be taken into consideration.	Downstage grouting techniques to a depth of 21-22 metres.		
SPILLWAY	18. Spillway batters and rock type.	GEOLOGY: Detailed mapping suggests preferred orientation of spillway centre line.	Analysis of rock discontinuities to determine angle of batters. Bulk of spillway excavation will go into zone 3 of rock fill dam.	
	19. Unstable boulders beneath spillway discharge lip.	Flip bucket of spillway terminates above jointed quartzite cliff face. Falls could possibly undermine flip bucket.	Rock bolting and guniting of quartzite face recommended.	
	20. Spillway water discharge upon river alluvials on right bank.	GEOPHYSICS: Max. depth of alluvials 5.2 m upon sound bedrock. No cavities or shear zone indicated.	Ponding of discharge water may possibly affect downstream toe of dam (see below).	
	21. Spillway design and water discharge.	HYDRAULICS: Engineering design: Model to simulate 10,000 year flood frequency.	Model tests indicate that the damming up of discharge water is not expected after erosion has removed alluvials.	
	22. Spray from spillway onto right bank and access road.	GEOLOGY: Saturation of opposite hillside may lead to slope movement on to access road or main outlet pipe.	Hillside monitor pegs along slope and placement of main outlet pipe along left bank recommended.	
	QUARRY	23. Quarry site.	GEOLOGY: Data on joints and bedding planes give stability report. Shear tests indicate frictional angles for quartzite bedding planes: 45° - 50°.	Quarry to be used as water treatment works site. Safe batters can be achieved during nearly all excavation work, particularly after removal of folded quartzite.
24. Quarry rock fill material.		MATERIALS LABORATORY: Drilling shows quartzite and dolomite with some siliceous siltstone.	Rock types tested for strength, porosity, permeability, sulphate soundness, Los Angeles abrasion, water absorption, slaking test and clay mineral content.	



LEGEND

- Poorly sorted gravel, poorly sorted sand, low plastic silts
- Hillside debris, silty debris, siltstone
- Shaly dolomite
- Soil from Trench 1
- Slate, or slaty dolomite
- Calcrete capping enclosing massive boulders
- Massive quartzite (F-MN)
- Fractured quartzite (F-MN)
- Quartzite fractured into large light blocks (MN-WN, MS-N)
- Quartzite blocks opened along deep joints (MN-WN, MS-N)
- Quartzite, fractured into smaller blocks, tight, low plastic (MN-WN, N-FW)
- As above, but showing open joints
- Highly fractured zone, small blocks, very tight to fairly loose
- Quartz veins, Trench or pit formation
- Small cavities along line of hillside fractures associated with unstable rock masses
- Overhanging boulders or outcrop
- 20° Strike and dip of bedding
- 30° Strike and dip of joint
- Shear zone
- DH 1 Core drill hole
- + 25 Survey station used for geological logging
- Survey pegs along fl. of exposure trenches
- Possible open bedding plane, beneath boulders

ROCK STRENGTH AND WEATHERING

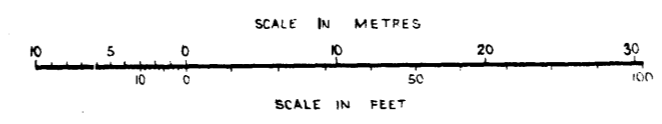
VW	very weak	(F)	Fresh
W	weak	(SW)	slightly weathered
MS	medium strong	(MW)	moderately weathered
S	strong	(HW)	highly weathered
VS	very strong	(CW)	completely weathered
		(A)	altered

LEFT HAND SIDE ALIGNMENT

Station	Rock Quality	Suggested Treatment
1	Massive quartzite (SW-MN)	Complete removal
2	Massive quartzite (SW-MN)	Complete removal
3	Massive quartzite (SW-MN)	Complete removal
4	Massive quartzite (SW-MN)	Complete removal
5	Massive quartzite (SW-MN)	Complete removal
6	Massive quartzite (SW-MN)	Complete removal
7	Massive quartzite (SW-MN)	Complete removal
8	Massive quartzite (SW-MN)	Complete removal
9	Massive quartzite (SW-MN)	Complete removal
10	Massive quartzite (SW-MN)	Complete removal
11	Massive quartzite (SW-MN)	Complete removal
12	Massive quartzite (SW-MN)	Complete removal
13	Massive quartzite (SW-MN)	Complete removal
14	Massive quartzite (SW-MN)	Complete removal
15	Massive quartzite (SW-MN)	Complete removal
16	Massive quartzite (SW-MN)	Complete removal
17	Massive quartzite (SW-MN)	Complete removal
18	Massive quartzite (SW-MN)	Complete removal
19	Massive quartzite (SW-MN)	Complete removal
20	Massive quartzite (SW-MN)	Complete removal
21	Massive quartzite (SW-MN)	Complete removal
22	Massive quartzite (SW-MN)	Complete removal
23	Massive quartzite (SW-MN)	Complete removal
24	Massive quartzite (SW-MN)	Complete removal
25	Massive quartzite (SW-MN)	Complete removal
26	Massive quartzite (SW-MN)	Complete removal
27	Massive quartzite (SW-MN)	Complete removal
28	Massive quartzite (SW-MN)	Complete removal
29	Massive quartzite (SW-MN)	Complete removal
30	Massive quartzite (SW-MN)	Complete removal
31	Massive quartzite (SW-MN)	Complete removal
32	Massive quartzite (SW-MN)	Complete removal
33	Massive quartzite (SW-MN)	Complete removal
34	Massive quartzite (SW-MN)	Complete removal
35	Massive quartzite (SW-MN)	Complete removal
36	Massive quartzite (SW-MN)	Complete removal
37	Massive quartzite (SW-MN)	Complete removal
38	Massive quartzite (SW-MN)	Complete removal
39	Massive quartzite (SW-MN)	Complete removal
40	Massive quartzite (SW-MN)	Complete removal
41	Massive quartzite (SW-MN)	Complete removal
42	Massive quartzite (SW-MN)	Complete removal
43	Massive quartzite (SW-MN)	Complete removal
44	Massive quartzite (SW-MN)	Complete removal
45	Massive quartzite (SW-MN)	Complete removal
46	Massive quartzite (SW-MN)	Complete removal
47	Massive quartzite (SW-MN)	Complete removal
48	Massive quartzite (SW-MN)	Complete removal
49	Massive quartzite (SW-MN)	Complete removal
50	Massive quartzite (SW-MN)	Complete removal
51	Massive quartzite (SW-MN)	Complete removal
52	Massive quartzite (SW-MN)	Complete removal
53	Massive quartzite (SW-MN)	Complete removal
54	Massive quartzite (SW-MN)	Complete removal
55	Massive quartzite (SW-MN)	Complete removal
56	Massive quartzite (SW-MN)	Complete removal
57	Massive quartzite (SW-MN)	Complete removal
58	Massive quartzite (SW-MN)	Complete removal
59	Massive quartzite (SW-MN)	Complete removal
60	Massive quartzite (SW-MN)	Complete removal
61	Massive quartzite (SW-MN)	Complete removal
62	Massive quartzite (SW-MN)	Complete removal
63	Massive quartzite (SW-MN)	Complete removal
64	Massive quartzite (SW-MN)	Complete removal
65	Massive quartzite (SW-MN)	Complete removal
66	Massive quartzite (SW-MN)	Complete removal
67	Massive quartzite (SW-MN)	Complete removal
68	Massive quartzite (SW-MN)	Complete removal
69	Massive quartzite (SW-MN)	Complete removal
70	Massive quartzite (SW-MN)	Complete removal
71	Massive quartzite (SW-MN)	Complete removal
72	Massive quartzite (SW-MN)	Complete removal
73	Massive quartzite (SW-MN)	Complete removal
74	Massive quartzite (SW-MN)	Complete removal
75	Massive quartzite (SW-MN)	Complete removal
76	Massive quartzite (SW-MN)	Complete removal
77	Massive quartzite (SW-MN)	Complete removal
78	Massive quartzite (SW-MN)	Complete removal
79	Massive quartzite (SW-MN)	Complete removal
80	Massive quartzite (SW-MN)	Complete removal
81	Massive quartzite (SW-MN)	Complete removal
82	Massive quartzite (SW-MN)	Complete removal
83	Massive quartzite (SW-MN)	Complete removal
84	Massive quartzite (SW-MN)	Complete removal
85	Massive quartzite (SW-MN)	Complete removal
86	Massive quartzite (SW-MN)	Complete removal
87	Massive quartzite (SW-MN)	Complete removal
88	Massive quartzite (SW-MN)	Complete removal
89	Massive quartzite (SW-MN)	Complete removal
90	Massive quartzite (SW-MN)	Complete removal
91	Massive quartzite (SW-MN)	Complete removal
92	Massive quartzite (SW-MN)	Complete removal
93	Massive quartzite (SW-MN)	Complete removal
94	Massive quartzite (SW-MN)	Complete removal
95	Massive quartzite (SW-MN)	Complete removal
96	Massive quartzite (SW-MN)	Complete removal
97	Massive quartzite (SW-MN)	Complete removal
98	Massive quartzite (SW-MN)	Complete removal
99	Massive quartzite (SW-MN)	Complete removal
100	Massive quartzite (SW-MN)	Complete removal

RIGHT HAND SIDE ALIGNMENT

Station	Rock Quality	Suggested Treatment
1	Massive quartzite (SW-MN)	Complete removal
2	Massive quartzite (SW-MN)	Complete removal
3	Massive quartzite (SW-MN)	Complete removal
4	Massive quartzite (SW-MN)	Complete removal
5	Massive quartzite (SW-MN)	Complete removal
6	Massive quartzite (SW-MN)	Complete removal
7	Massive quartzite (SW-MN)	Complete removal
8	Massive quartzite (SW-MN)	Complete removal
9	Massive quartzite (SW-MN)	Complete removal
10	Massive quartzite (SW-MN)	Complete removal
11	Massive quartzite (SW-MN)	Complete removal
12	Massive quartzite (SW-MN)	Complete removal
13	Massive quartzite (SW-MN)	Complete removal
14	Massive quartzite (SW-MN)	Complete removal
15	Massive quartzite (SW-MN)	Complete removal
16	Massive quartzite (SW-MN)	Complete removal
17	Massive quartzite (SW-MN)	Complete removal
18	Massive quartzite (SW-MN)	Complete removal
19	Massive quartzite (SW-MN)	Complete removal
20	Massive quartzite (SW-MN)	Complete removal
21	Massive quartzite (SW-MN)	Complete removal
22	Massive quartzite (SW-MN)	Complete removal
23	Massive quartzite (SW-MN)	Complete removal
24	Massive quartzite (SW-MN)	Complete removal
25	Massive quartzite (SW-MN)	Complete removal
26	Massive quartzite (SW-MN)	Complete removal
27	Massive quartzite (SW-MN)	Complete removal
28	Massive quartzite (SW-MN)	Complete removal
29	Massive quartzite (SW-MN)	Complete removal
30	Massive quartzite (SW-MN)	Complete removal
31	Massive quartzite (SW-MN)	Complete removal
32	Massive quartzite (SW-MN)	Complete removal
33	Massive quartzite (SW-MN)	Complete removal
34	Massive quartzite (SW-MN)	Complete removal
35	Massive quartzite (SW-MN)	Complete removal
36	Massive quartzite (SW-MN)	Complete removal
37	Massive quartzite (SW-MN)	Complete removal
38	Massive quartzite (SW-MN)	Complete removal
39	Massive quartzite (SW-MN)	Complete removal
40	Massive quartzite (SW-MN)	Complete removal
41	Massive quartzite (SW-MN)	Complete removal
42	Massive quartzite (SW-MN)	Complete removal
43	Massive quartzite (SW-MN)	Complete removal
44	Massive quartzite (SW-MN)	Complete removal
45	Massive quartzite (SW-MN)	Complete removal
46	Massive quartzite (SW-MN)	Complete removal
47	Massive quartzite (SW-MN)	Complete removal
48	Massive quartzite (SW-MN)	Complete removal
49	Massive quartzite (SW-MN)	Complete removal
50	Massive quartzite (SW-MN)	Complete removal
51	Massive quartzite (SW-MN)	Complete removal
52	Massive quartzite (SW-MN)	Complete removal
53	Massive quartzite (SW-MN)	Complete removal
54	Massive quartzite (SW-MN)	Complete removal
55	Massive quartzite (SW-MN)	Complete removal
56	Massive quartzite (SW-MN)	Complete removal
57	Massive quartzite (SW-MN)	Complete removal
58	Massive quartzite (SW-MN)	Complete removal
59	Massive quartzite (SW-MN)	Complete removal
60	Massive quartzite (SW-MN)	Complete removal
61	Massive quartzite (SW-MN)	Complete removal
62	Massive quartzite (SW-MN)	Complete removal
63	Massive quartzite (SW-MN)	Complete removal
64	Massive quartzite (SW-MN)	Complete removal
65	Massive quartzite (SW-MN)	Complete removal
66	Massive quartzite (SW-MN)	Complete removal
67	Massive quartzite (SW-MN)	Complete removal
68	Massive quartzite (SW-MN)	Complete removal
69	Massive quartzite (SW-MN)	Complete removal
70	Massive quartzite (SW-MN)	Complete removal
71	Massive quartzite (SW-MN)	Complete removal
72	Massive quartzite (SW-MN)	Complete removal
73	Massive quartzite (SW-MN)	Complete removal
74	Massive quartzite (SW-MN)	Complete removal
75	Massive quartzite (SW-MN)	Complete removal
76	Massive quartzite (SW-MN)	Complete removal
77	Massive quartzite (SW-MN)	Complete removal
78	Massive quartzite (SW-MN)	Complete removal
79	Massive quartzite (SW-MN)	Complete removal
80	Massive quartzite (SW-MN)	Complete removal
81	Massive quartzite (SW-MN)	Complete removal
82	Massive quartzite (SW-MN)	Complete removal
83	Massive quartzite (SW-MN)	Complete removal
84	Massive quartzite (SW-MN)	Complete removal
85	Massive quartzite (SW-MN)	Complete removal
86	Massive quartzite (SW-MN)	Complete removal
87	Massive quartzite (SW-MN)	Complete removal
88	Massive quartzite (SW-MN)	Complete removal
89	Massive quartzite (SW-MN)	Complete removal
90	Massive quartzite (SW-MN)	Complete removal
91	Massive quartzite (SW-MN)	Complete removal
92	Massive quartzite (SW-MN)	Complete removal
93	Massive quartzite (SW-MN)	Complete removal
94	Massive quartzite (SW-MN)	Complete removal
95	Massive quartzite (SW-MN)	Complete removal
96	Massive quartzite (SW-MN)	Complete removal
97	Massive quartzite (SW-MN)	Complete removal
98	Massive quartzite (SW-MN)	Complete removal
99	Massive quartzite (SW-MN)	Complete removal
100	Massive quartzite (SW-MN)	Complete removal



DEPARTMENT OF MINES - SOUTH AUSTRALIA

LITTLE PARA RIVER - GEOLOGICAL INVESTIGATION
GROUT CAP ALIGNMENT - GEOLOGICAL PLAN

ENGINEERING GEOLOGY SECTION: J.C. BIRD, D.M. GLOUGHER, D.M. GLOUGHER
 Director of Mines: J.C. BIRD
 SCALE: 1:250
 No. 73-979
 DATE: 14th Dec 1973

However, a mass concrete dam was considered. Geological investigations showed that the shear zone had displaced the thick quartzite stratum (unit 12) from the left hillside onto the right hillside giving an apparently sound right abutment bank suitable for a mass concrete dam.

The dolomitic siltstone on the left bank was however considered too fractured and too poor a quality to support a mass concrete dam. Another reason for abandoning the idea of building a mass concrete dam was because of the asymmetrical topography of the valley at this site.

A concrete decked rock fill dam was chosen and its layout together with other associated works is shown in Figure 7. The upstream grout cap and base of the decking was constructed as a series of blocks labelled from 'A' at the top of the left abutment to 'W' at the top of the right abutment (Figure 7).

The Outlet Pipe passes beneath the spillway lip on the left hand side of Little Para River and connects the outlet duct via the Control House to the Water Treatment Works.

Originally it was planned to run the Outlet Pipe along the right river bank but spillway discharge spray could saturate the bank leading possibly to a soil-slip failure of the hillside and dislocation of the outlet pipe. Because of this possibility, pegs were placed along the hillside and monitored over a period of eighteen months. The results showed no hill side movement and although the outlet-pipe was finally located on the left bank the knowledge was useful in assessing the potential stability of the hillside above the batters of the permanent access road located along the right bank on a similar route to that initially proposed for the outlet pipe.

THE GROUT CAP AND GROUT CURTAIN

Diamond core drilling and water pressure testing down to 20.0 m along the grout cap alignment showed rock conditions suitable for the formation of a grout curtain.

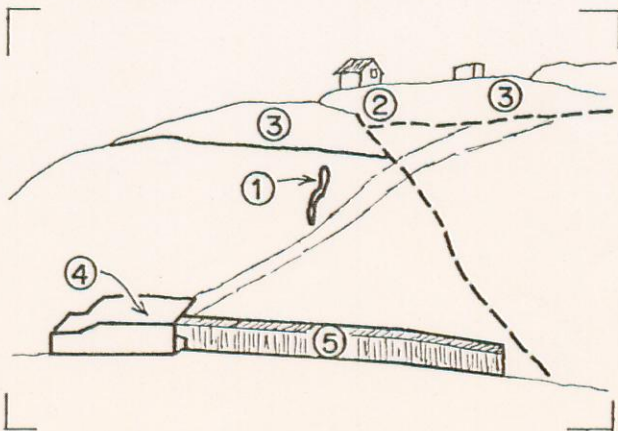
The left bank grout cap (Figure 10) traverses dolomitic siltstone (Unit 13) and the right bank grout cap (Figure 11) traverses for most of its length massive quartzite (Unit 12). Where the grout cap passes into the parapet wall, at the top of the right bank, it traverses dolomitic siltstone (Unit 11).

High pressure water sluicing along the left bank alignment exposed: hillside stress relief fractures; seams of completely weathered dolomitic siltstone; vuggy-shattered quartz veins; open joints; and a shear zone. All these features were examined during the mapping of the alignment and some required adjustment, during construction, of the grout cap design.

Water sluicing along the right bank alignment exposed: large blocks of massive quartzite separated by wide infilled joints; quartz veins; zones of closely jointed quartzite and weathered quartzite; weathered dolomitic siltstone and calcrete. None of these geological features required specific design treatment but constant assessment was required during grout cap excavation.

THE SPILLWAY

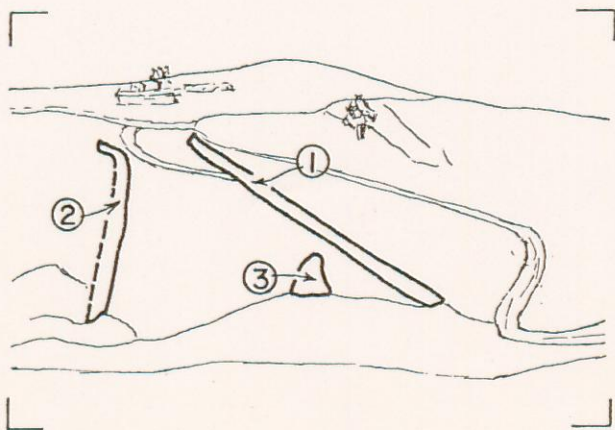
Two locations for the spillway were originally considered. One to be excavated into the left bank hillside adjacent to the rockfill dam and another - the final choice - to breach the hillside on the left bank, 100 m downstream of the dam. The first site considered was unacceptable mainly because the relatively shallow excavations for the spillway would have been in dolomitic siltstone already known to show hillside pressure relief fractures and seams



NEGATIVE NO. 26761 - Sept. 1974
 THE LEFT ABUTMENT AND OUTLET
 DUCT

1. Hillside stress relief fracture.
2. Shear Zone.
3. Displacement of slaty dolomitic siltstone.
4. Base of outlet Tower.
5. Outlet Duct.

FIG. 10



NEGATIVE NO. 27417 - Dec. 1976
THE RIGHT ABUTMENT
1. Right bank grout cap.
2. Early investigation trench.
3. Excessive excavation along
a minor shear zone back-
filled with Zone 1 material.

FIG. 11

completely weathered to some considerable depth - both features which would require extensive treatment. Also, work on a spillway located along the left bank hillside would interfere with construction of the dam immediately below. To be capable of discharging flood water into the river at a safe distance away from the downstream toe of the dam such a spillway would have required the design of a sharp bend. Although this would have been possible to design it was not favoured.

THE QUARRY

The basic initial requirements in the search for the main materials quarry was to find sufficient quantities of Zone 2, Zone 3 and Zone 4 rockfill (Figure 12). Because Zones 2 & 4 require strong, fresh rock the investigations for a quarry site were restricted to areas where good quartzite could be extracted.

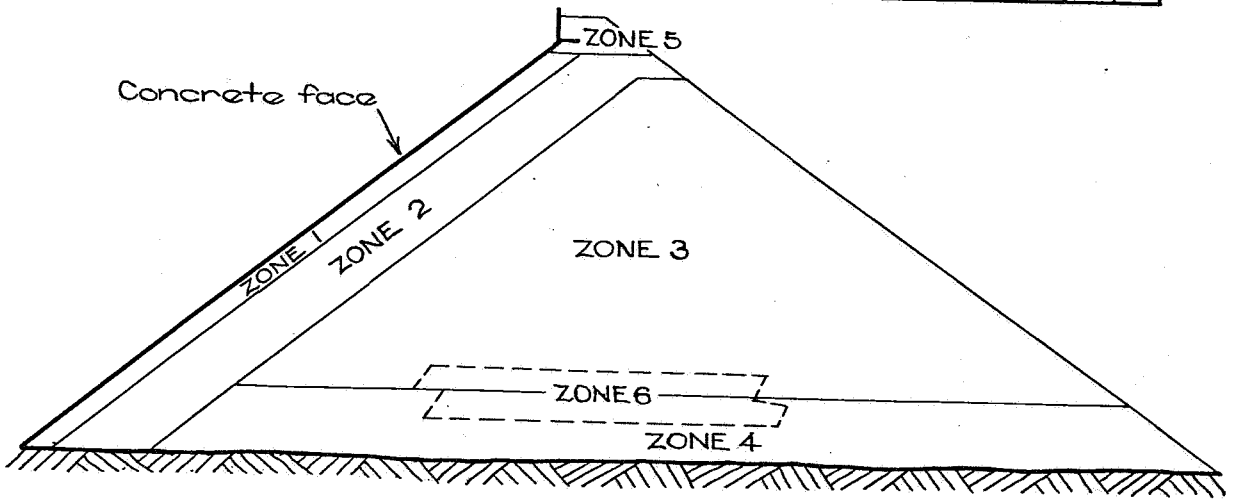
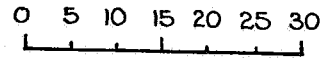
However the final site was chosen (Figure 7) so as the final excavation could be used for the construction of a water treatment works.

ACCESS ROADS, AND OTHER WORKS

Location of the access roads and the site office was governed by topography and location of the dam and appurtenant structures. Excavation through strong quartzite was unavoidable and at some locations road-side batters adjacent to the offices needed to be assessed for possible slope instability. Although all road batters are stable, individual falls of small boulders will occur during the lifetime of the batter faces.

General site safety involved removal of all obviously unstable and doubtfully stable boulders lying on steep hillsides above all access roads, offices and construction areas.

METRES



DESIGN CRITERIA FOR ROCKFILL ZONES

- ZONE 1 of well graded durable rock compacted in horizontal layers not exceeding 0.5 m. in thickness when compacted and graded as specified.
- ZONE 2 of up to 1000 mm rock with not greater than 20% passing a 26.5 mm sieve, compacted in horizontal layers not exceeding 1.0m in thickness when compacted.
- ZONE 3 of up to 1000 mm rock with not greater than 30% passing a 26.5 mm sieve. Compacted in horizontal layers not exceeding 1.0 m thickness when compacted.
- ZONE 4 of up to 1300 mm rock with not greater than 20% passing a 26.5 mm sieve. Compacted in horizontal layers not exceeding 1.3m in thickness when compacted
- ZONE 5 of up to 500 mm. rock with not greater than 40% passing a 26.5 mm sieve. Compacted in horizontal layers not exceeding 0.5 m in thickness when compacted.
- ZONE 6 of up to 300 mm rock with not more than 40% passing a 26.5 mm sieve. Compacted parallel to the duct centre line in horizontal layers approx. 2.0m. thick when compacted.

Fig. 12

		DEPARTMENT OF MINES — SOUTH AUSTRALIA	Scale :
Compiled : J. C. B.		LITTLE PARA DAM CROSS SECTION SHOWING ROCKFILL ZONES	Date : 15 - 1 - 76
Drn. J.W.	Ckd		Drq. No.
			SI2070

II MATERIAL TESTS

INTRODUCTION AND SUMMARY

Table 4: Summary of Main Rock Types

ROCK TESTS

Physical Properties

Shear Tests

Assessment for Rockfill zones and concrete aggregate

SOIL TESTS AND CLAY MINERALOGY

Road Fill

Weathered Dolomitic Siltstone

Table 5: Occurrence of cavities and weathered seams

Mineralogy

Table 6: Mineralogy of weathered dolomitic siltstone

Dispersion Tests

Permeability Tests

Ring Density Tests

INTRODUCTION AND SUMMARY

Testing of rock, clay seams and soil in the vicinity of the dam site was carried out during the detailed geological investigation of the dam site and the construction period.

Of major importance was the assessment of the various rock types for possible inclusion in the several rockfill zones of the dam embankment and the suitability of some rock aggregate for on site concrete. A total of twenty nine diamond cored holes were drilled during the investigation and construction periods and core was taken from some of these holes and used for testing.

The material investigation included the petrographic description of rock types; analyses of clay; concrete aggregate testing; rock strength testing of quartzite and dolomitic siltstone; ring density tests and permeability tests on weathered seams of dolomitic siltstone. The results of material testing are summarised below:-

.... Two main rock types occur over the dam site and quarry area, namely quartzite and dolomitic siltstone. The quartzite is felspathic and the dolomitic siltstone shows a variable carbonate content also it is more siliceous when occurring beneath the base of the quartzite.

.... Only the quartzite is suitable for concrete aggregate.

.... The quartzite and the siliceous dolomitic siltstone are suitable for rockfill in the dam Zones 1 and 4.

.... Fresh to weathered dolomitic siltstone is suitable for Zone 3.

.... Breakdown of the dolomitic siltstone due to weathering produces a sandy silt with a 10-20 percent clay content.

The clay may be nearly all montmorillonite or montmorillonite and vermiculite.

- The quartzite shows an unconfined compressive strength within the range 85-296 MPa.
- Unconfined compressive strength values for the dolomitic siltstone fall within the range 30 MPa - 105 MPa.
- Axial and diametral point load tests on the dolomitic siltstone give values of 1.7 - 13.8 MPa.
- Permeability tests on samples of completely weathered dolomitic siltstone give values 1×10^{-5} - 5×10^{-7} cm/sec.
- Dry densities from Ring Density Tests carried out on the dam embankment gave values of 1840-2150 kg/m³ which is mainly within the required specifications.

Results of the petrological descriptions of the two major rock types are summarised in Table 22 Appendix 4 and in Table 4 below.

TABLE 4

SAMPLE	ANALYSIS	PETROLOGICAL DESCRIPTION
QUARTZITE	Quartz 55%-95%	
	Feldspars 5%-45%	Quartzite to Metamorphosed
	Opaques)	arkosic sandstone
	Sericite) Traces only	
	Chlorite)	
DOLOMITE	Dolomite 90%-95%	Dolomitic Siltstone
	Quartz 3%-6%	(Phyllitic dolomite, foliated
	Opaques 2%-4%	with Schistose texture)

ROCK TESTS

Physical Properties

A summary of the physical tests carried out on specimens of dolomitic siltstone and quartzite is shown in Tables 24 & 26, Appendix 4, which also includes Table 25, showing some values of unconfined compressive and point load strengths related to drilling speed in the quarry site. (Definitions of rock strengths are given in Appendix 5).

Drilling rates appear to vary from 10.0-20.0 metres per hour in quartzite to 25.0 - 35.0 metres per hour in fresh to moderately weathered dolomitic siltstone and up to 78.0 metres per hour in highly weathered dolomitic siltstone.

The axial point load strength index for some of the samples of dolomitic siltstone taken close to the base of the quartzite where it becomes siliceous, show values in the extremely high rock strength range.

Low values (0.5 MPa) for diametral point load strength indices are considered to be due to the high fissillity of the dolomitic siltstone in a direction approaching normal to the axis of the core tested. Owing to this fissillity true diametral tests are very difficult to carry out. Unconfined compressive strength tests for moderately weathered to strongly weathered dolomitic siltstone fall within the range 30 MPa to 105 MPa. Values for highly weathered dolomitic siltstone were not taken.

Low unconfined compressive strength values for the quartzite are accounted for by the high felspar content of some of the samples. The felspar is rarely fresh and shows breakdown into kaolin and sericite.

It was noted during core testing that as weathering decreases with depth, core samples at depth showed an increase in their unconfined compressive strength.

Shear Tests

Using the Hoeck portable shear testing machine, peak and residual angles of friction were derived in the laboratory for bedding planes in the quartzite and dolomitic siltstone on samples taken from the proposed quarry site. (Attewell et al., 1976; Hoek and Bray 1974). The work was carried out by the Consulting Engineers, Coffey and Partners Proprietary Ltd. Results of the tests are included in Appendix 3.

Folding of the quartzite has caused the bedding plane to dip into the quarry at approximately 22° and samples taken were tested across this plane. Values for the shearing angle of 45° - 50° were recorded for the quartzite thus reflecting the interlocking nature of the surface of the bedding planes. Bedding planes within the dolomitic siltstone are far smoother than in the quartzite and angles of friction of 25° - 30° were recorded. These values of friction were useful as a guide when assessing batter safety (See Hazeldene 1975) during excavation of access roads and the quarry (Appendix 3).

Assessment for Rockfill zones and concrete aggregate

Samples of quartzite, and dolomitic siltstone were tested at the Engineering and Water Supply Department's Ottoway Laboratory for their suitability for use in the free draining zones of the rock-fill dam (Zones 1,2 and 4) and for use as on-site concrete aggregate. The results of these tests and petrological descriptions are summarised in Appendix 4.

Accelerated weathering test results (Table 25, Appendix 4) show that the dolomitic siltstone is acceptable for rockfill Zone 3, the fines produced from these tests having low plastic clay properties. However, the petrological examination carried out by the Australian Mineral Development Laboratories, (Appendix 4) showed that the phyllosilicates, reactive silica, dolomite and pyrite content of the dolomitic siltstone disallowed their use as concrete aggregate. Only the quartzite and some siliceous dolomitic siltstone proved acceptable for use in both the rockfill zones and as aggregates but because of the economics of assembling an on-site crusher, aggregate was bought from a nearby commercial supplier. On site quality control for quartzite aggregate would have been difficult owing to the wide range in feldspar content of the quartzite and its associated variably weathered nature.

Moderately weathered to slightly weathered dolomitic siltstone was used only in the main mass of the dam, Zone 3. The mineralogy of the completely weathered dolomite is discussed under Soil Tests.

SOIL TESTS AND CLAY MINERALOGY

Road Fill

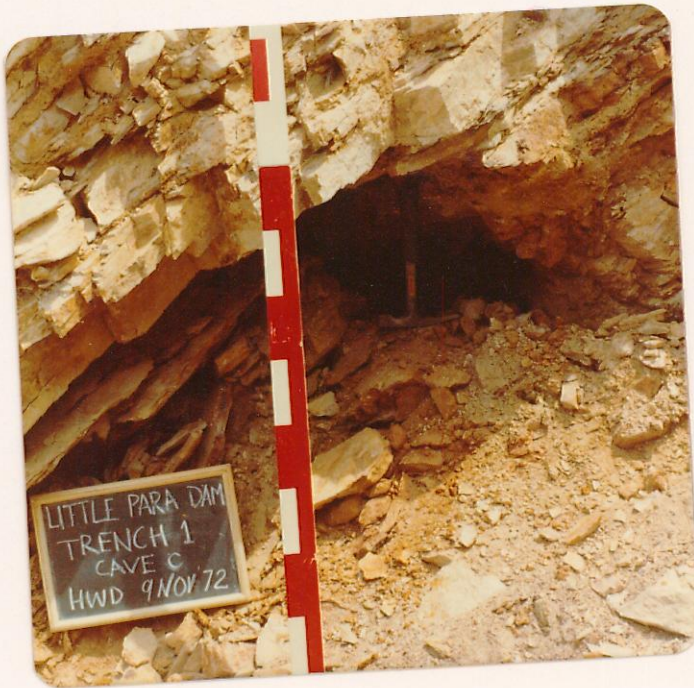
Hillside colluvium from the foot of the quarry and water treatment works site was analysed with respect to using the colluvium as fill for temporary access roads. The analysis (Figure 64, Appendix 4) shows a soil comprised of approximately fifty percent gravel, forty percent silt and clay and ten percent sand. This is a very poorly graded gravel. The fines give a plasticity index of 32.7. The colluvium was considered most unsuitable for use as road fill, satisfactory compaction being extremely difficult to achieve without the addition of sand sized material.

Fill material for temporary roads was obtained on site from any conveniently located excavation into weathered bedrock. Permanent roads were formed of crushed broken quartzite placed beneath a graded base brought onto the site from a nearby commercial gravel quarry.

Weathered Dolomitic Siltstone

Completely to highly weathered seams of dolomitic siltstone passing beneath the grout cap alignment and across the grout curtain could have led to water leakage and possible piping and would therefore have been detrimental to these structures had they been left undiscovered and untreated. The occurrence on the dam site of seams of weathered dolomitic siltstone is shown in Table 5. Samples were taken from the seams and forwarded to the Australian Mineral Development Laboratories for petrographic description. The on site treatment of completely weathered dolomitic siltstone is discussed in Part III: Design and Construction.

Seams of completely weathered dolomitic siltstone and associated cavities (Figure 13) occur within the gradational strata between the base of the quartzite and top of the dolomitic siltstone. These strata are referred to in the field as transitional strata and were first exposed in an early inspection trench running down the right abutment. In earlier reports on the site they were variously described as flaggy quartzite, quartz-sericite meta-siltstones or phyllitic dolomite or foliated dolomitic siltstone and indicate the varying nature of the transitional strata. Samples of moderately weathered to completely weathered transitional strata were forwarded to the Soils and Foundations Laboratory Netley, of the Engineering & Water Supply Department. Grading curves from their mechanical analysis (Figure 65) show the weathered samples to be: 10% clay; 55% silt and 35% fine to medium grained sand.



NEGATIVE NO. 23112 - Nov. 1972
CAVITY EXPOSED IN THE RIGHT
ABUTMENT INSPECTION TRENCH
Looking downstream.

FIG. 13

TABLE 5

OCCURRENCE	INVESTIGATION	DESCRIPTION	TREATMENT*
RIGHT ABUTMENT 1. Early investigation trench down right abutment.	Trench 2.0 m - 3.0 m deep excavated downstream of dam axis from EL.145 m to EL.110 m.	Three cavities in transitional strata; all approx. 1.0 m x 0.5 m wide; min 2.5 m lateral extent. Assoc. weathered seams.	Samples adjacent to cavities analysed by A.M.D.E.L. (See Appendix). No treatment. Backfilled with rockfill.
2. Trench for parapet wall foundation Blocks T,U,V,W.	Trench 3.0 m - 4.0 m deep at top of right abutment. Exposure of Transitional Strata.	+ (CW) dolomitic siltstone seam up to 3.0 m ² thick. Three small holes (2 cm ² area: min 100 mm deep). Solution - piping feature?	Samples analysed (see Appendix 4). Trench infilled with construction concrete as parapet wall foundation. (Increase of potential leakage path).
3. Outcrops upstream and downstream of the dam axis with 100 m of the dam.	Eight back hoe pits 2.0 m deep located outcrops of the transitional strata.	(CW) seams from 0.3 m to 2.80 m thick exposed.	No treatment of upstream outcrops; exposures used for mapping. (CW) seam assumed to pass beneath the right abutment. Reverse sand filter placed in downstream outcrop.
4. Beneath the grout cap.	(a) Early Investigation Core Hole DH1 (EL.130) (b) Early Investigation Core Hole DH2 (EL.144) (c) Grout curtain cored check hole DH24 (EL.122).	80 cm core loss 11.55-12.35 m. 20 cm core loss 9.10-0.30 m. 25 m core loss 10.25-10.50 m. At intersection of a shear zone and weathered seam (see Fig.42).	No treatment. No treatment. Hole grouted following a water pressure test.
LEFT ABUTMENT 5. Grout Cap.	Excavation of group cap foundation and batters.. (a) Block A/B (b) Block E	0.50 m thick at EL.140. 0.70 m thick at EL.120. Both seams persisted to depth and laterally.	Excavated down to approx. 1.0 m across width of grouting and filled with dental concrete. Samples forwarded to AMDEL.
SPILLWAY 6. Behind wall slabs R1, R2, L2, L3 and partly beneath floor slabs FR1, FL2.	Excavation of spillway channel wall and spillway floor.	Occurs beneath a quartzite station; 0.50 m thick, continuous.	Dental treatment.
7. Passing behind wall slabs FR6, FL7 and beneath floor slab F7.	As for 6 above.	Associated with a vuggy quartz vein. Discontinuous.	Dental treatment.

* Methods of treatment is summarised in Figure
+ (CW) Completely weathered, see Appendix

LITTLE PARA DAM
OCCURRENCE OF CAVITIES AND SEAMS OF COMPLETELY WEATHERED DOLOMITIC SILTSTONE

Mineralogy

Because the cavities found beneath the right abutment were associated with the dolomitic siltstone and because the main mass of the dam, Zone 3, is constructed of dolomitic siltstone, knowledge other than its physical properties was required on the nature of the breakdown of the siltstone. Three samples thought to represent progressive breakdown of the dolomitic siltstone were therefore forwarded to the Australian Mineral Development Laboratories for petrological analysis and mineralogical descriptions. Details of their report are summarised in Table 6 below.

TABLE 6
MINERALOGY OF WEATHERED
DOLOMITIC SILTSTONE: SUMMARY

SAMPLE NO.	DESCRIPTION	CONDITION	PERCENT		
			QUARTZ MICA FELDSPAR	DOLOMITE	VERMICUL-MONTMORILL- ITE ONITE
1	Moderately foliated phyllitic dolomitic siltstone.	least weathered rock of the three samples.	30-40	60-70	
2	Quartz-sericite Metasiltstone	highly weathered	90-95	Traces (assoc. with limonite)	5-10
3	Quartz-sericite Metasiltstone	completely weathered (ML-CL)*	55-70 (sericite 15-25)	Nil ⁺	15-20

* UNIFIED SOIL CLASSIFICATION (Appendix 5)

+ PROBABLY NEVER AS MUCH PRESENT AS IN SAMPLE NO. 1.

Examination of the clay products found within the weathered seams show that for most samples the clay fraction is dominant with sub-dominant to accessory range quantities of kaolin type clays and vermiculite. This was also true for ten clay samples taken from thin seams adjacent to the cavities found within the transitional strata. Dolomite occurred in only one out of the ten samples as a dominant mineral. In all other nine samples dolomite was completely absent, calcite occurring in eight of them, in three of these in dominant quantities, elsewhere appearing as an accessory or a trace mineral with montmorillonite and mica. Samples of low plastic-clay taken from infilled joints in the quartzite beneath the grout caps on the right bank show quartz as the dominant mineral.

The low dolomite content of the above samples compared to the high dolomite content of the unweathered parent rock indicate a breakdown of the dolomite into calcite and in some cases limonite, the dolomite being slightly ferroan. The magnesium ions released from the dolomite are relocated to form vermiculite and montmorillonite and possibly also the formation of sericite and to a lesser extent chlorite. It appears unlikely that the vermiculite is an intermediate product in the formation of montmorillonite from sericite, the decisive factors in whether vermiculite or montmorillonite forms being related to the concentration of magnesium ions and to the degree of drainage (intensity of leaching).

In dolomite free horizons, where a relative paucity of magnesium ions could be anticipated during weathering, kaolinite may be expected to form rather than montmorillonite and vermiculite.

Because the vermiculite has a high cation exchange capacity and may be present in weathered dolomitic siltstone laying adjacent to the grout curtain, consideration was given to the possible long term reaction between the cement of the grout curtain and the vermiculite. Fortunately this capacity of the vermiculite is only continuously active in areas of water circulation and in fact the cement in the grout curtain has a high free lime content which should help to stabilize dispersive clays as the calcium replaces the sodium.

Permeability values of weathered dolomitic siltstone containing vermiculite are low and the effect of the vermiculite upon the cement of the grout curtain is not considered a problem.

Dispersion Tests

Seams of completely weathered dolomitic siltstone occur in the right abutment at the base of the quartzite (Unit 10) in the transitional strata (Unit 11) and towards the top of the left abutment predominantly as thin seams. Because of possible leakage of reservoir water through the grout curtain via these seams a study was made of their dispersive nature.

A grading of samples taken from the main occurrence of weathered dolomitic siltstone, at the top of the right abutment, beneath the parapet wall, show a composition in the region 30% sand, 50% silt and 10% clay (See Figure 66, Appendix 4). The clay is dominantly montmorillonite and vermiculite.

Dispersion Factors

The cause of dispersion (Perry 1973) can be summarised as:

1. Concentration of cations in the dilution (reservoir) water
2. Type of clay
3. The exchangeable sodium percentage (ESP). That is, the ratio of single valence cations (sodium is the main concern) to the total exchangeable cations (Cation Exchange

Capacity. CEC). This ratio may also be referred to as the Sodium Adsorption Ratio (SAR) when only double valence cations are considered when calculating the cation exchange capacity.

$$\text{ESP} = \frac{\text{Na}^+}{\text{Na}^+ + \text{Ca}^{++} + \text{Mg}^{++} + \text{K}^+ + \text{M}^+}$$

$$\text{SAR} = \frac{\text{Na}}{0.5 (\text{Ca} + \text{Mg})} = \frac{\text{Na}^+}{0.5 (\text{Ca}^{++} + \text{Mg}^{++})^{\frac{1}{2}}}$$

both express values of a cation
in milli equivalents/litre

(milliequivalent = $\frac{\text{milligrams of cation} \times \text{valence of cation}}{\text{Atomic weight}}$)

4. Total concentration of exchangeable monovalent and divalent cations in the double layer surrounding clay particles.

Test Results

It is advisable that both the crumb test and pin-hole test be used as physical tests to check the dispersive nature of a clay sample. Unfortunately the pin-hole test was not carried out on Little Para Dam samples owing to unavailability of the equipment.

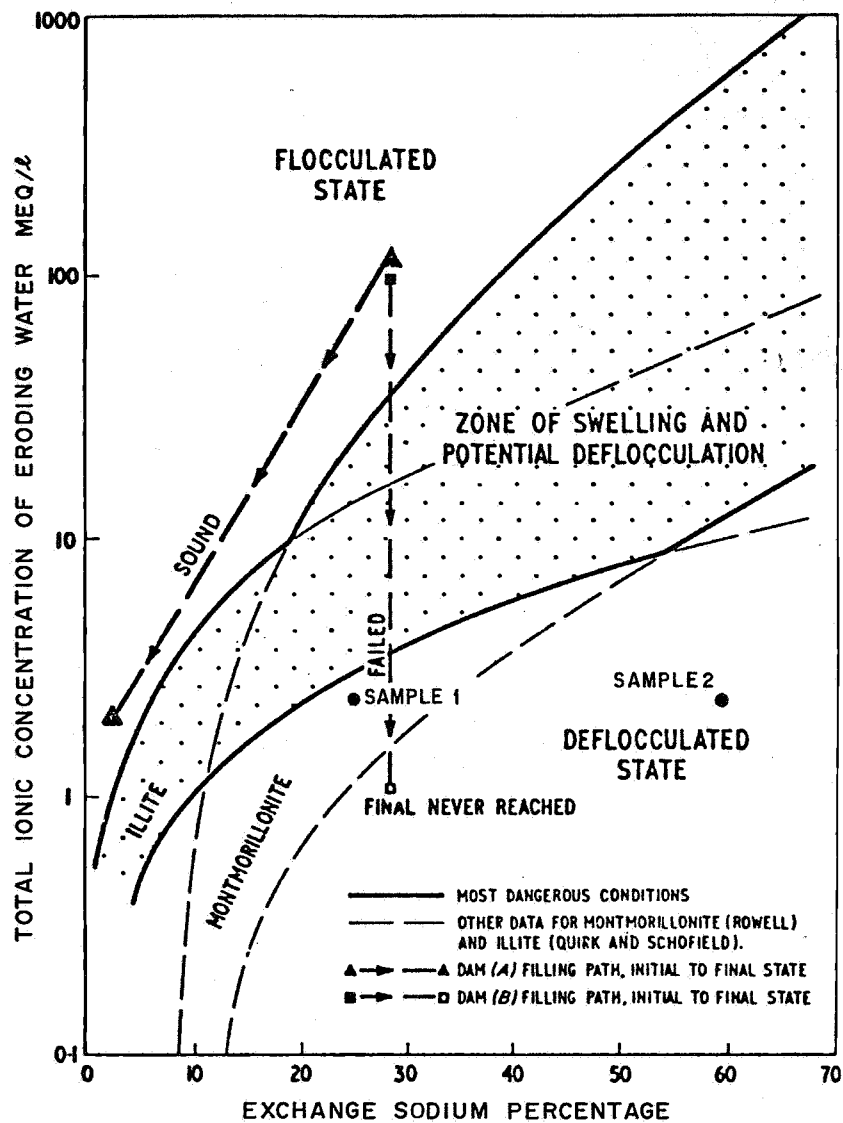
An extract analysis was carried out on two samples of completely weathered dolomitic siltstone. Sample 1 was taken from the early inspection trench on the right abutment, (possibly leached) and sample 2 from the Spillway Channel wall (Construction Block WL3). The latter sample is considered typical of unleached weathered dolomitic siltstone.

Results of Extract Analysis
on Samples of Completely Weathered Dolomitic Siltstone
(Netley Laboratory)

	Sample 1		Sample 2	
	Milli-Gms/Litre	Milli-equi/litre	Milli-Gms/litre	Milli-equi/litre
Na	43	1.87	710	30.87
Ca	90	4.5	202	10.1
Mg	23	1.9	138	11.4
		-----		-----
Total		7.3		52.4
%Na =	Na	27%		59%
	----- Na+Mg+Ca			
<hr/>				
Sodium Absorption Ratio:				
(SAR)		1.05		9.4

The lowest likely cation content of Adelaide water is 3 Milli-equivalents/ litre (Information from Bolivar Laboratories, Engineering and Water Supply Dept.). According to Figures 14 and 15 the clay fraction in Sample 2 is a dispersive clay, and Sample 1 may be dispersive (Sherard et al. 1976).

It has been assumed that the weathered materials in Sample 1 and Sample 2 were originally similar. This seems likely because of the similarity of rock type from which they were formed. The difference in cation content would be due to rain water percolating through the material and leaching out the cations. The leaching process removes monovalent in preference to di-valent atoms which would explain the lower sodium percentage in Sample 1. The rain water would also tend to disperse the clay in its natural state and this would assist the erosion process. Small holes might be enlarged by the percolating rain water even under low heads. This is a possible cause of the cavities exposed in the early inspection trench excavated into the weathered dolomitic siltstone on the right abutment.



Sample 1 — Taken from Inspection Trench.
Little Para Dam.

Sample 2 — Taken from Spillway Channel Wall.
Little Para Dam.

* (see Penny 1973)

FIG. 14

DEPARTMENT OF MINES AND ENERGY
SOUTH AUSTRALIA

SCALE Diagrammatic

COMPILED: J.C. Beal.

LITTLE PARA DAM

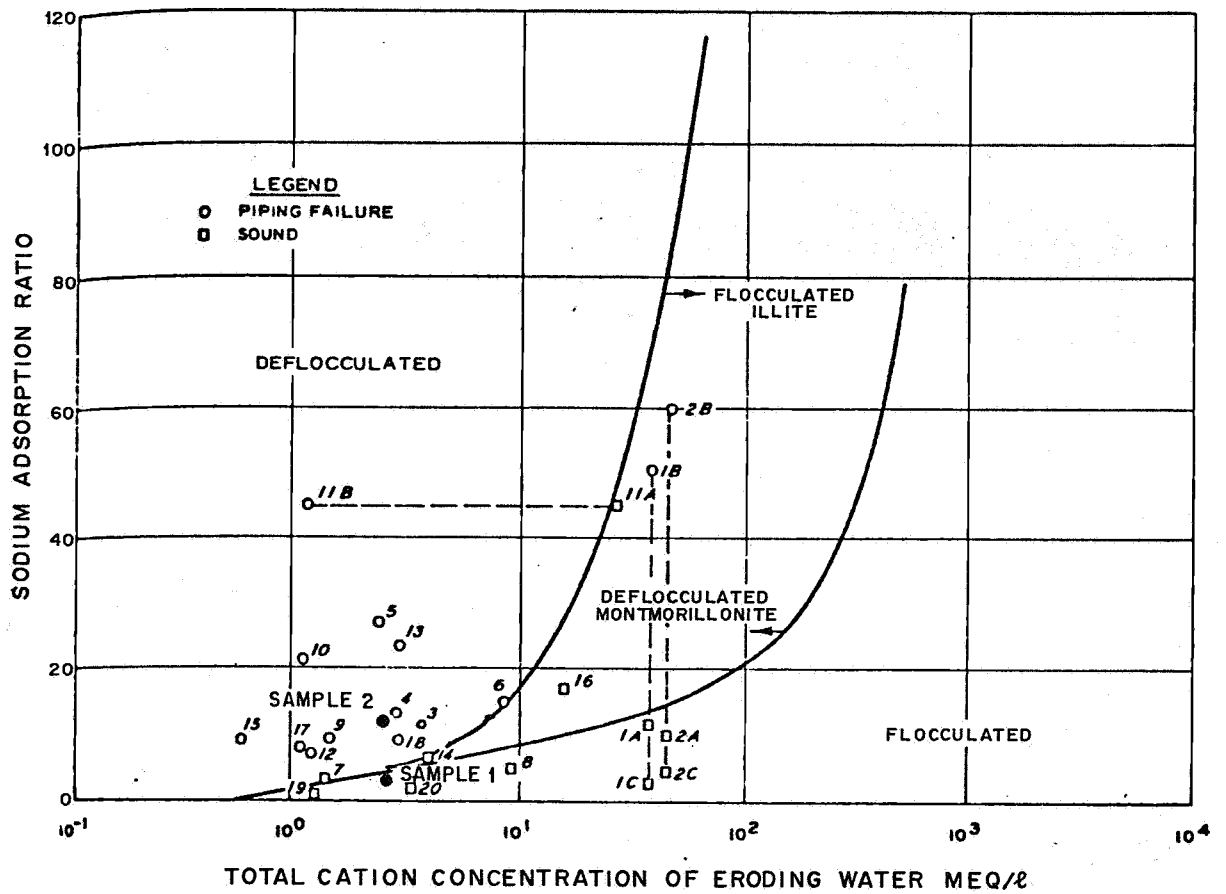
DATE 8-5-78

DRN: G.J.T. CKD.

PREDICTION OF PIPING FAILURE
IN EARTH DAMS *

PLAN NUMBER

S13400



Sample 1 — Taken from Inspection Trench, Right Abutment, Little Para Dam.

Sample 2 — Taken from Spillway Channel Wall, Little Para Dam.

* (see Penny 1973)

FIG 15

DEPARTMENT OF MINES AND ENERGY
 SOUTH AUSTRALIA

SCALE: Diagrammatic

COMPILED: J.C. Beal.

DATE: 8-5-78

DRN: G.J.T. CKD:

LITTLE PARA DAM
 CORRELATION OF FIELD PERFORMANCE
 OF EARTH DAMS IN AUSTRALIA*

PLAN NUMBER

S13401

1126

Possibility of Grout Curtain Failure.

With a dispersive clay, small water paths may be rapidly enlarged by water, under quite low heads as the clay deflocculates and disperses into particles small enough to be carried by the flow.

It is unlikely that the water pressure cleaning and grouting operations have removed all erodible material from the area of the grout curtain and that in sections of the curtain a dispersion failure caused by the diluting waters of the initial drilling of the reservoir is possible (Stapledon 1977). However, it is believed that the following factors will reduce the likelihood of curtain failure in the right abutment:

1. The clay in samples taken near the outcrop of the seam is already leached, as in Sample 1, and is therefore less likely to give a future dispersion failure.
2. Clay makes up only 10% of the weathered product. Silt and sand which make up most of the remaining material act as filters and should hold the dispersing clay (Perry 1973). This appears to have been observed on samples tested by the Soil Section of the Engineering and Water Supply Dept.
3. The cement in the grout has a high free lime content which should help to stabilize dispersive clays as the calcium replaces the sodium.
4. A clay dispersion test (crumb test) was done on the leached sample and no dispersion was noticed.

Nevertheless two precautionary measures to reduce and keep a check on the effects of curtain leakage have been carried out downstream of weathered seams known to occur within the right bank grout curtain.

Firstly, two interconnecting reverse sand filter trenches have been put into the right bank immediately downstream of the parapet wall. These have been excavated into the full thickness of the outcrop of the weathered seam and backfilled with washed concrete sand and are intended to block any dispersion path that may form. The trench terminates downstream and away from the rockfill of the dam in a concrete trough to allow visual observation of any discharge.

A second precaution has been to drill two observation bores on the right abutment adjacent to the downstream toe, one downstream of the parapet wall, another at the same elevation as the shear zone which runs beneath grout cap Block M. They will allow measurement of potentiometric levels immediately downstream of the dam. The observation bores will be read daily until it is established that the grout curtain is performing satisfactorily then they will be read on a weekly basis to monitor long term safety (See Section V: Surveillance Programme and Project Evaluation).

Permeability Tests

The Left Bank Grout Cap

A sample of completely weathered dolomitic siltstone taken from the base of a stress relief fracture on the left bank grout cap alignment was forwarded to the Engineering and Water Supply Department's Soils and Foundation Testing Laboratory. Grading curves, specific gravity and permeability tests were requested and the results are included in Appendix 4. The sample showed traces of rock fabric and immediately decomposed after being placed in distilled and mains water. Examination by binocular microscope revealed the presence of many voids up to 1.5 times the diameter of the silty grains. A mechanical

analysis for this sample is given in Figure 66 Appendix 4.

A permeability test on this sample (specific gravity 2.87) gave an approximate value of 1.15×10^{-5} m/sec.

Although the permeability of low permeable foundations may be further reduced by embankment pressure (Londe 1977 and Stapleton 1976) these values of permeability are for isolated seams of completely weathered dolomitic siltstone which may occur at depth below the embankment. It is believed that the permeability of this material will not be altered by the overlying 50 metre high rockfill embankment. The treatment of seams completely weathered is discussed in Part III; DESIGN AND CONSTRUCTION.

The Right Bank Grout Cap

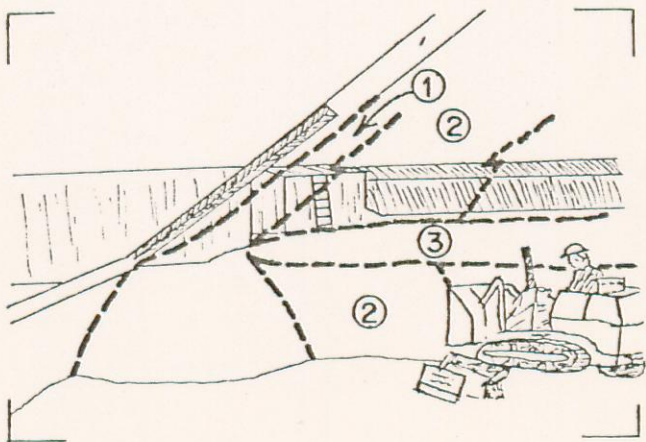
Three tube samples taken from the sides of the parapet wall foundation trench excavated into the seam of completely weathered dolomitic siltstone at the top of the right bank grout cap gave a permeability value of 5×10^{-7} m/sec. The two values of permeability give a range of values of water movement from approximately 3 metres to 15 metres per year (slightly permeable: see Appendix 5) indicating that leakage through the grout curtain, initiated by piping within the completely weathered dolomitic siltstone is not likely.

Quality control on Embankment Rockfill

Six ring density tests were carried out on the embankment in rockfill zones 1,2,3,4 and 6 by resident soil laboratory assistants. Each test included the full thickness of the lift (1.0 metres) where the compacted rockfill was excavated by manual pick and carefully weighed ensuring no loss of fines. Volume was calculated by lining the excavated hole with an impermeable membrane and filling with water. A summary of the ring density tests is shown in Table 27 and Figure 67, Appendix 4.

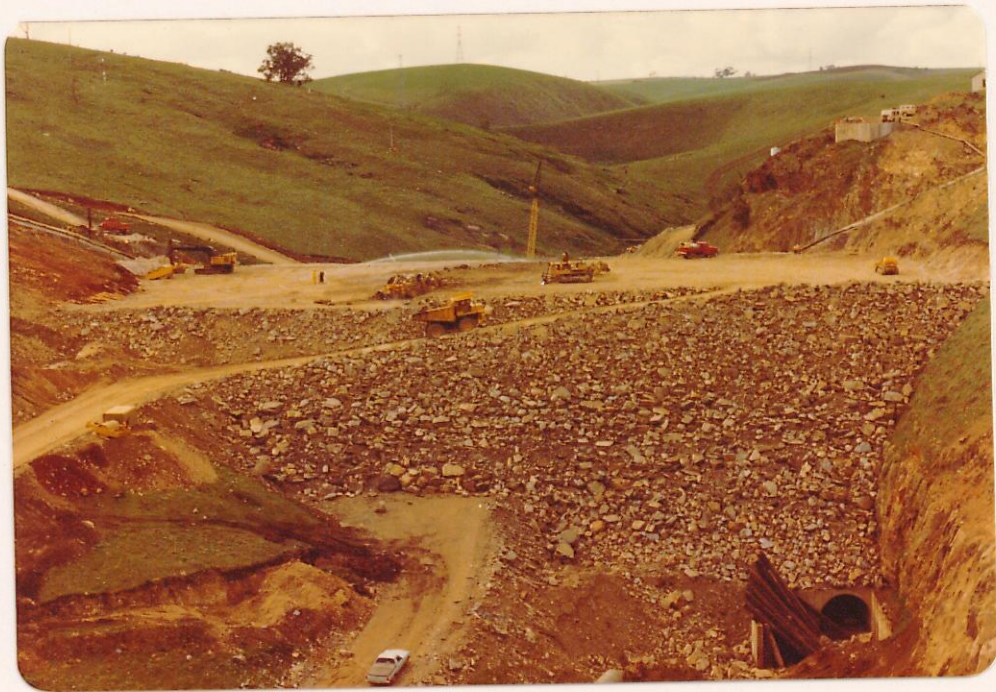
Average results gave dry densities in the range 2 010 kg/m³ (125.41b/cu ft) - 2 280 kg/m³. An early ring test on Zone 1 (Figure 16) gave a low dry density value of 1 840 kg/m³ resulting from accidental mixing with unacceptably low quality zone 2 material. The top 0.5 metres of this contaminated material was removed and replaced with clean, fresh quartzite.

Up to this stage the embankment had been compacted dry but because the general rock quality had deteriorated from then onwards water was sprayed onto the rockfill during compaction (Figure 17).



NEGATIVE NO. 27028 - Nov. 1976
EMBANKMENT
Looking towards left abutment.
1. Zone 1 rock fill.
2. Zone 2 rock fill.
3. Zone 6 rock fill.

FIG. 16



NEGATIVE NO. 27985 - July 1976
SLUICING OF ROCK FILL
Looking upstream.

FIG. 17

III DESIGN AND CONSTRUCTION

GEOLOGY, DAM DESIGN AND CONSTRUCTION

THE RESERVOIR

THE RIGHT ABUTMENT

THE LEFT ABUTMENT

THE GROUT CAPS AND PARAPET WALL

Table 7: Preparation of Grout Cap Blocks

THE GROUT CURTAIN

THE OUTLET TOWER, OUTLET DUCT AND CONTROL HOUSE

THE SPILLWAY

Assessment of Batter Slopes

The Channel Walls

THE QUARRY

Rock Quality and Quantity

Quarry Excavation and Initial Fracture Survey

THE EMBANKMENT

DESIGN AND CONSTRUCTION

GEOLOGY; DAM DESIGN AND CONSTRUCTION

Geological data was presented to the design engineers in three stages. Firstly they received results of the initial geological investigation. This allowed the choice of the dam site and dam type.

Secondly, usually at the request of the designer, specific geological data required for a particular aspect of the project was presented.

Thirdly, the site geologist inspected the construction work on a daily basis. Wherever the exposed geology proved different to expected geology the designers were informed, who then, if necessary, inspected the geology on site. In certain cases the different exposed geology necessitated minor design modifications but more normally continued excavation to sounder rock, or the remedial treatment of unacceptably poor quality rock, sufficed to allow construction to continue.

A diagrammatic summary of the different kind of construction features which required geological attention is shown in Figure 18.

THE RESERVOIR

Although early mapping proved a watertight reservoir an area of concern for possible leakage was on the right abutment adjacent to the dam where completely weathered outcrops of dolomitic siltstone occur immediately upstream of the dam (Figure 19). A weathered seam of dolomitic siltstone passes beneath the right abutment near to the full supply level of the dam and it was thought that impounded water could find a leakage path beneath the right abutment of the dam via these seams. For this reason some thought was given to sealing off any potential leakage path by placement of a clay blanket across the outcrops of the weathered

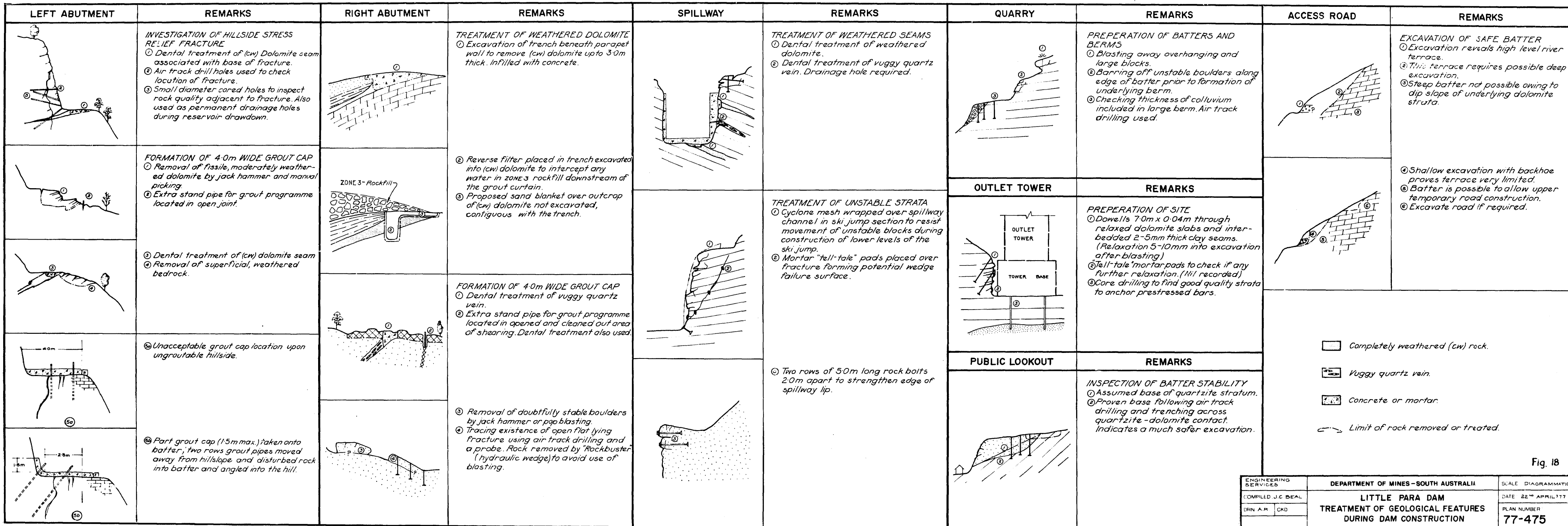
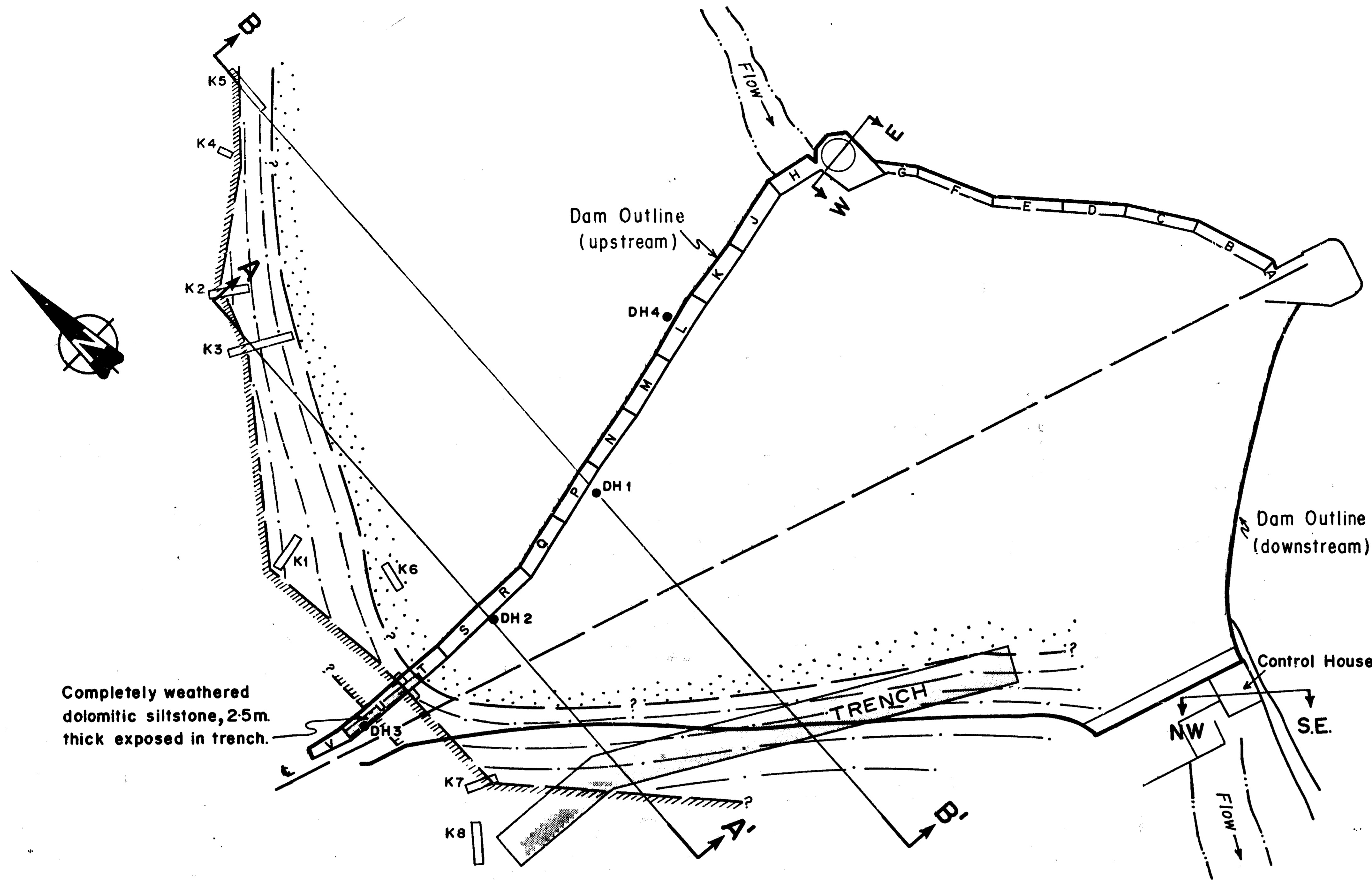

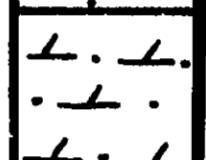


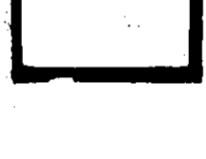


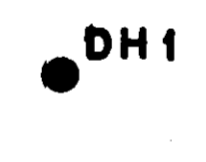
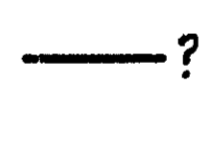




Fig. 18

ENGINEERING SERVICES	DEPARTMENT OF MINES - SOUTH AUSTRALIA	SCALE DIAGRAMMATIC
COMPILED J.C. BEAL	LITTLE PARA DAM	DATE 22 ND APRIL '77
DRN A.R. CKD	TREATMENT OF GEOLOGICAL FEATURES DURING DAM CONSTRUCTION	PLAN NUMBER 77-475



LEGEND.

-  Massive quartzite.
-  Transitional strata.
(Flaggy quartzite/dolomitic siltstone.)
-  Completely weathered dolomitic siltstone.
(up to 3.0metres thick (cross section).)
-  Dolomitic siltstone.
-  Grout cap block.
-  Back-hoe pit
-  Drillhole.
-  Approx. base of massive quartzite.
-  Boundary of completely weathered dolomitic siltstone (plan).
-  See Fig. 23
-  See Fig. 25

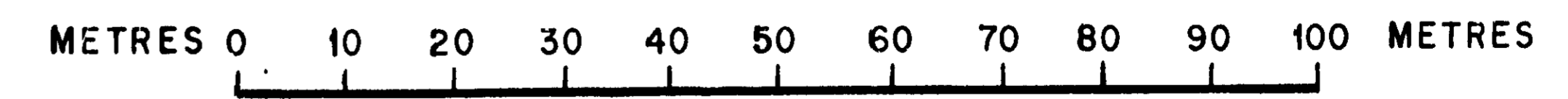
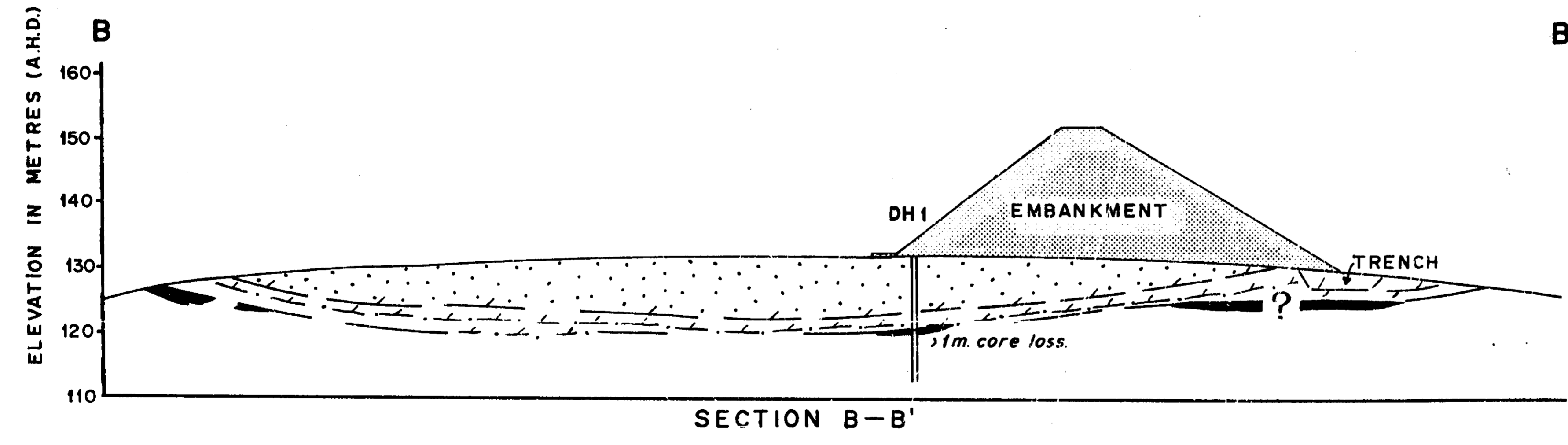
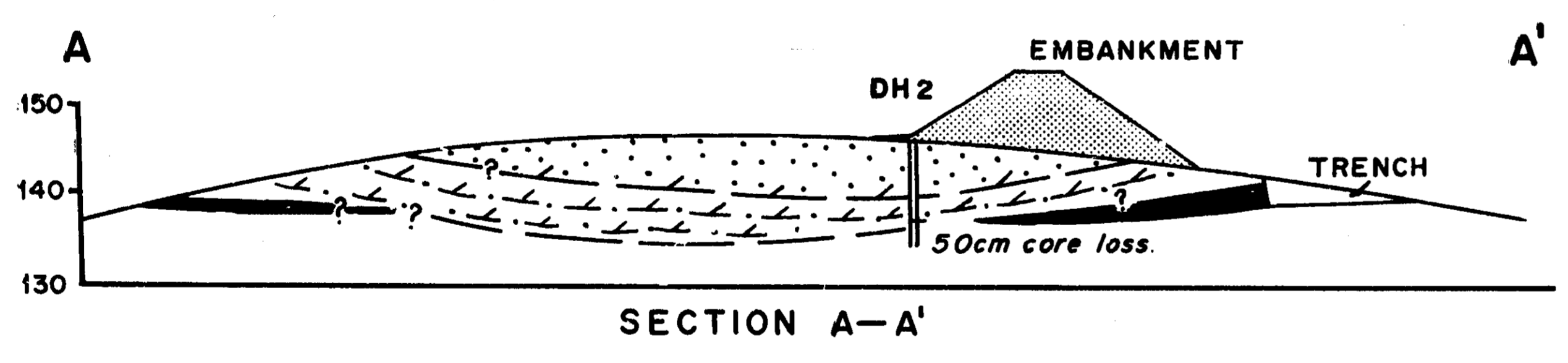


Fig 19

		DEPARTMENT OF MINES AND ENERGY SOUTH AUSTRALIA		SCALE As shown
COMPILED J. C. Beal.		LITTLE PARA DAM RIGHT ABUTMENT GEOLOGY LOCATION OF WEATHERED SEAMS OF DOLOMITIC SILTSTONE		DATE MAY 1978
DRN. G. J. T.	CKD.			PLAN NUMBER 78-385

seams. It was decided not to do this because the stability of such a blanket would be affected by the continual filling and drawdown of the reservoir. It was also thought that a successful grout curtain would obviate the need for the clay blanket.

THE RIGHT ABUTMENT

Early trenching on the right abutment exposed three small cavities associated with weathered dolomitic siltstone found at the base of the quartzite stratum, UNIT 12 (Fig. 13). This was another factor indicating the unsuitability of the site for a concrete gravity dam.

The extent of the cavities and possible affect upon the grout cap and grout curtain was assessed during the detailed investigation by diamond core drilling. Drill holes along the grout cap and into the right abutment indicated that although the cavities were not widespread weathered seams of dolomitic siltstone occurred beneath the quartzite stratum, and their interception should be anticipated when drilling the grout curtain holes.

During clean up of the right abutment, quartzite bedrock was exposed after removal of a few millimetres to approximately 1.0 metre of topsoil and loose moderately weathered quartzite boulders. Removal of calcrete, localised to the top of the right abutment and up to 800 mm thick, exposed completely weathered dolomitic siltstone. This weathered strata was trenched 1.0 - 4.0 m into moderately strong dolomitic siltstone. The trench was filled with concrete and served as the foundation of the parapet wall.

The quartzite proved to be weathered and fractured adjacent to a shear zone traversing the right abutment and passing through grout cap Block M. (Figure 7). Ease of removal of the bedrock resulted in the inadvertent excavation of a wide trench 15 m - 20 m long into the abutment beneath the embankment. The trench ran along the line of the shear zone and was approximately 5 metres wide with walls 4 - 5 m high. These walls were permanently damp where the shear zone was exposed. In addition to this the excavation exposed an early exploration drill hole which flowed constantly at approximately 0.25 litres per second.

To avoid future saturation of overlying rock fill the trench was filled with Zone 1 quality rockfill which connected with free draining Zone 4 material at the base of the dam.

THE LEFT ABUTMENT

Because of the sparse vegetation very little clearing of the left abutment was necessary and this was carried out during placement of the embankment. A cavity, discoid in shape, and of the approximate dimensions 4.0 m long, 4.0 m high and 1.50 m wide occurred at EL 114 m, 15 metres downstream of the grout cap at the site of a hillside fracture. Solution and fretting of the dolomitic siltstone had widened the fracture locally, and the resultant cavity did not appear to be continuous into any other part of the abutment. All loose slabs were removed by back hoe and the cavity filled with grout via air track holes drilled into the top of the cavity.

Completely weathered dolomitic siltstone was exposed between EL 121 and EL 124, extending from the grout cap to 20 metres downstream. After removal by backhoe down to less weathered siltstone, zone 1 rockfill was placed in a trench, excavated between the grout cap and the downstream face, running adjacent to the left bank abutment.

This was done to channel any leaking reservoir water away from embankment rockfill. In retrospect the use of concrete instead of zone 1-rockfill would have been preferable, reducing seepage velocities and hence decreasing the chances of solution and erosion of the seam of completely weathered dolomitic siltstone.

THE GROUT CAPS AND PARAPET WALL

The alignment of the grout caps was chosen following results obtained from diamond drilling along a proposed alignment initially located after studying data from the early geological assessment of the site. After drilling, the overburden, along the alignment, was removed using high pressure water sluicing. The alignment was subdivided into grout cap blocks and each block then individually inspected and geologically logged (See Figures 8 & 9).

The grout cap blocks are labelled A-W excluding letters I and O. On the left abutment the blocks run from A at the top down to G; from W down to H on the right abutment. The Control Tower foundation is between and contiguous with blocks G and H.

Excavation of the grout cap and batters on the left bank was by pre-split blasting and the rubble was removed using a winch secured dozer which pushed the waste over the hillside into the river below. At this stage the river had been temporarily diverted through 1.5 metre diameter pipe and thus no material entered the river water.

Excavation on the right bank grout cap alignment did not require blasting. Apart from some areas requiring dental treatment, sound fresh to moderately weathered bedrock was exposed requiring very little preparation and exhibited no surface deterioration between the period of excavation and grout cap concrete laying (contrast this with Roberts et al. 1975).

Geological Examination of a Grout Cap Block

The geological conditions encountered along the grout cap alignment and subsequent treatment are shown in Figures 8,9 and 18 and are summarised in Table 7.

Approval for pouring the grout cap concrete was given only after the two following basic criteria had been satisfied. Firstly, there had to be a minimum width of 4 metres of capping upon sound, stable, groutable bedrock. It is within this four metre width that the two rows of grout curtain holes were drilled and any loose slabs of bedrock or weathered strata associated with open joints or stress relief fractures removed. (Figure 21).

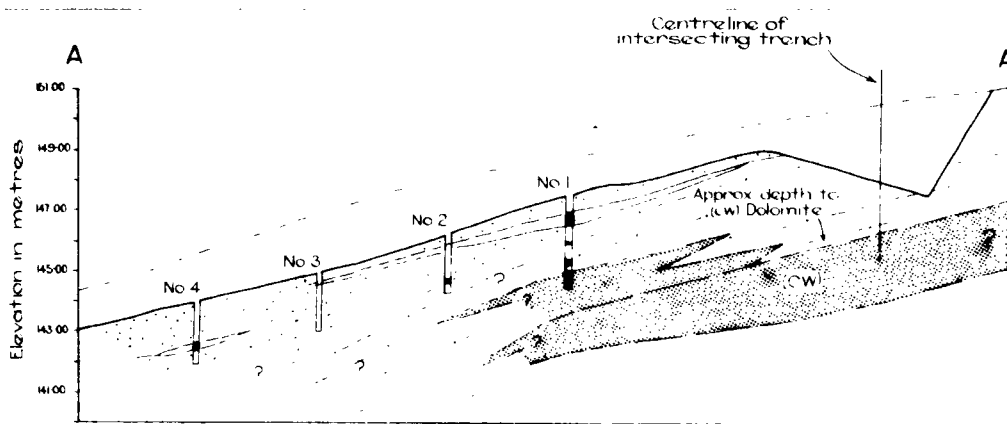
Secondly, all loose, highly weathered bedrock had to be removed and in-filled fractures widened and cleaned out. Before individual grout cap blocks were poured the reinforcing bars were laid and attached to dowel bars grouted into 3.0 metre deep holes drilled into the bedrock. These dowel holes assisted in giving an indication of the bedrock quality at shallow depth. In particular it allowed the persistence of open fractures to be noted and traced across the grout block. This was achieved by using a hand held probe made of 10 millimetre wide steel rod. A thin rigid tip 15 mm long welded at right angles onto one end of the rod allowed the user to feel for open fractures. The rod was graduated in 50 mm intervals.

Because of these weathered seams consideration was given early in the design of the dam to placing a reverse filter (Figure 20) at the top of the right abutment, beneath the downstream embankment rockfill, as a precaution against dispersion and subsequent erosion of the weathered dolomitic siltstone.

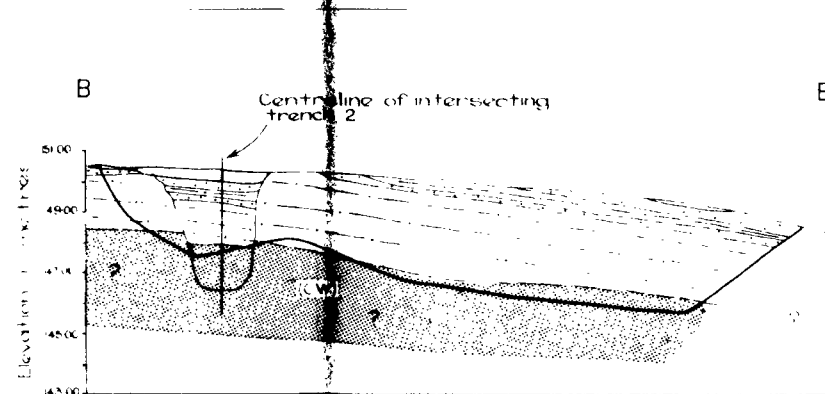
ITEM NO.	FEATURE	LOCATION	TREATMENT OF BLOCK	MODIFICATION OF DESIGN
1	Loose slabs of dolomitic siltstone, resting upon slightly weathered - moderately weathered siltstone.	Left bank	Surface removal only. Surface accepted providing siltstone is not too weathered (slightly weathered - moderately weathered is acceptable limits).	If associated with open joints may require extra grout hole ie. extra stand pipe to be placed before pouring of block.
2	Loose slabs of dolomitic siltstone resting upon highly-completely weathered siltstone.	Left bank. Base of Outlet Tower.	Removal of slabs. Check thickness of underlying weathered seam and trench out where necessary. Approx. 0.75 - 1.0 m depth. Trench infilled with concrete.	To attain 4.0 metre width of groutable rock - sometimes necessary to extend part of the 4.0 metres up onto the hillside batter.
3	Slightly-completely weathered siltstone or quartzite associated with seams parallel to bedding or open joint.	Left bank. Right bank.	Dental treatment as for ITEM NO. 2 above.	Place extra stand pipe for grouting in the open joint.
4	Intersecting joints producing a highly-completely weathered area in quartzite usually about 1 metre square areal extent. Often associated with quartz veins.	Right bank.	Complete removal usually down to 1.0 - 1.5 m and infilled with concrete.	
5	Presence of thin (0.05 - 0.10 m) non-groutable seams beneath acceptable quartzite bounders.	Right Bank Beneath Tower.	Removal of boulder and thin seam. Checking persistence of thin seam by small diameter jack hammer drilling.	

TABLE 7 - LITTLE PARA DAM - PREPARATION OF GROUT CAP BLOCKS

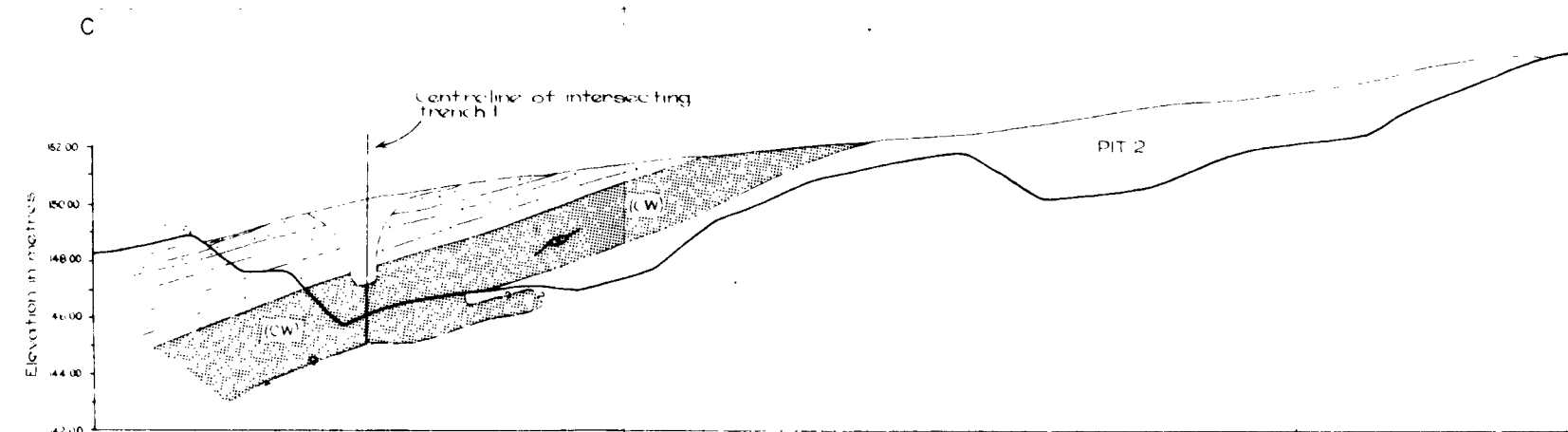
ITEM NO.	FEATURE	LOCATION	TREATMENT OF BLOCK	MODIFICATION OF DESIGN
6	Presence of completely weathered dolomitic siltstone (2.5 - 3.0 m thick) beneath the quartzite.	Right Bank Beneath Block U.	Complete removal of dolomitic siltstone along a trench parallel to dam axis beneath the parapet wall.	Trench infilled with concrete and formed contiguously with the parapet wall. Reverse filter placed beneath rockfill across dam width in this area.
7	Calcrete adhering to grout cap block surface.	Right bank	Removal of all but the hardest calcrete.	



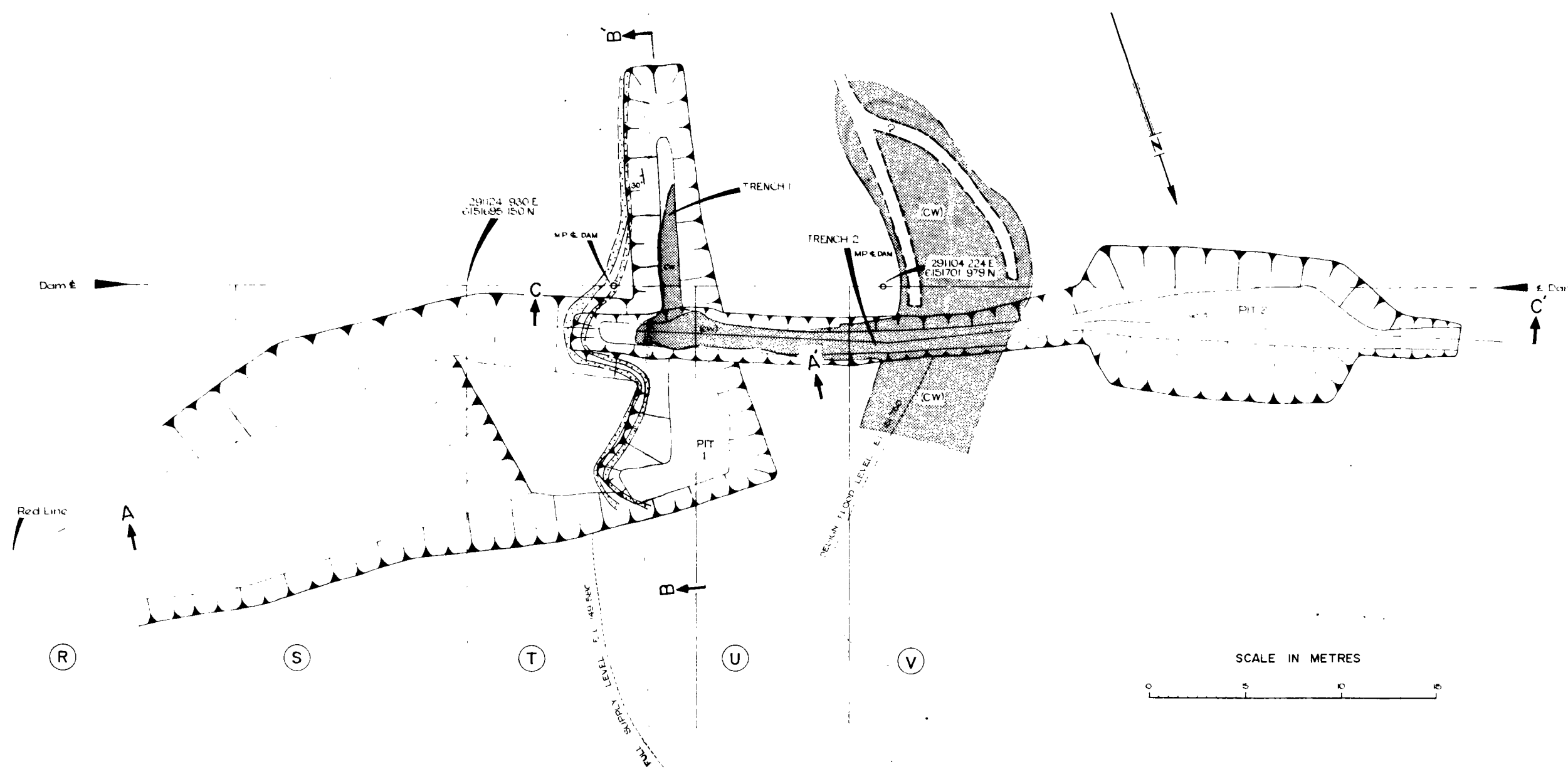
SECTION A-A'
LOOKING DOWNSTREAM



SECTION B-B'
ALONG TRENCH 1



SECTION C-C'
ALONG TRENCH 2 LOOKING DOWNSTREAM



LEGEND

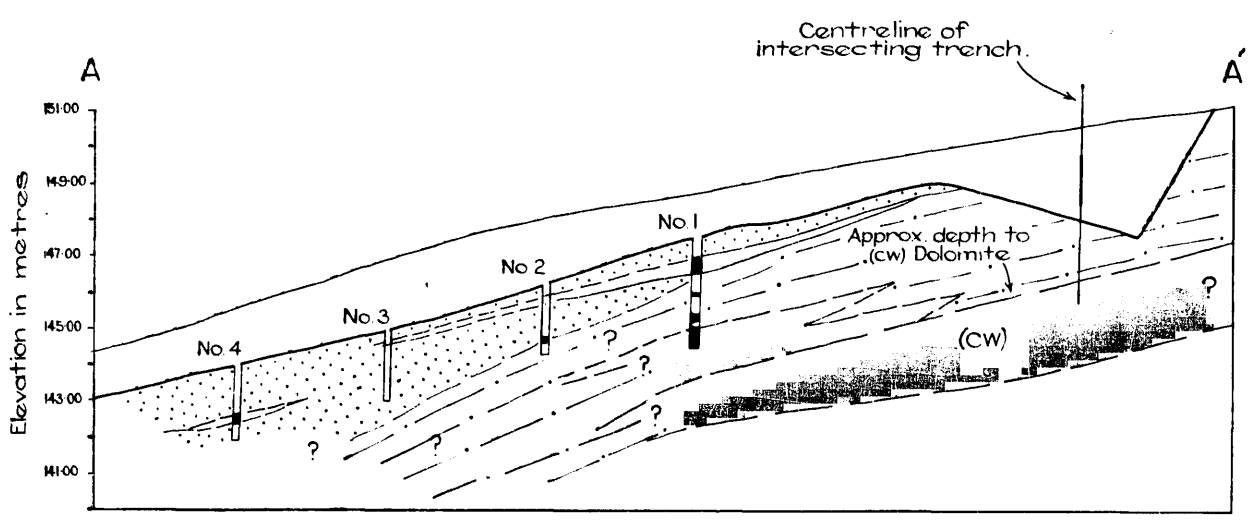
- Transitional Strata
- Massive Quartzite
- Dolomitic Siltstone (Groutable)
- Dolomitic Siltstone (Completely weathered)
- Geological boundary (definite)
- Geological boundary (inferred)
- Cavity 110m extent 40mm x 30mm
- Strike and dip of bedding
- Approximate location of small diameter drill holes into quartzite unit
- Interpretation of soft seams intersected during drilling of air track holes No1-No4
- Location of reverse filter trench

SCALE IN METRES

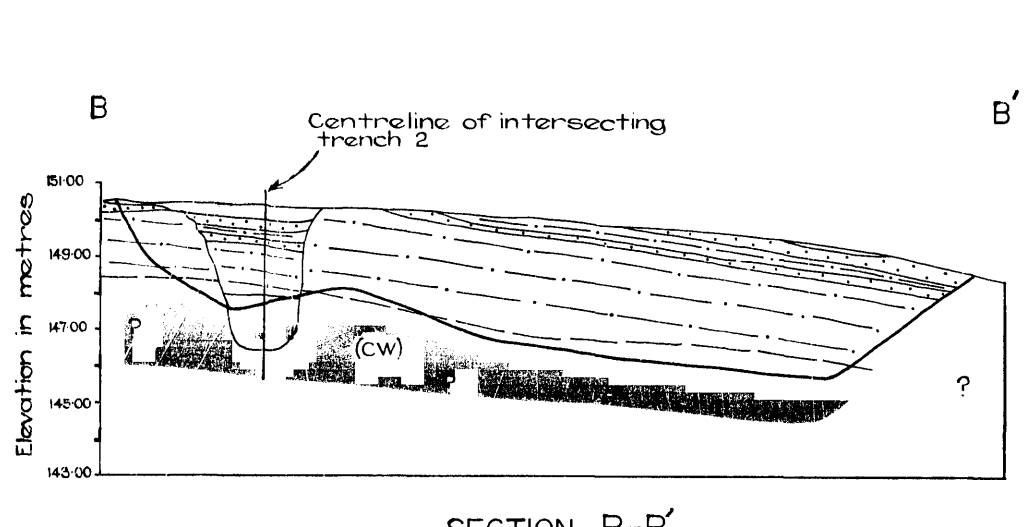


Fig. 20

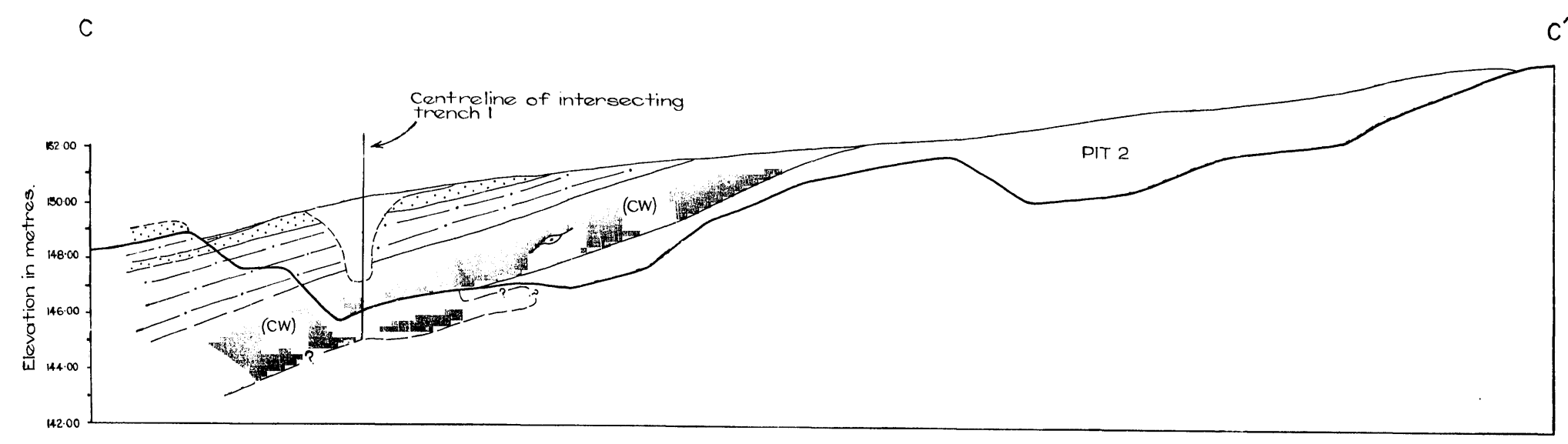
DEPARTMENT OF MINES-SOUTH AUSTRALIA			
LITTLE PARA DAM RIGHT ABUTMENT GROUT CAP EXCAVATION OF DOLOMITIC SILTSTONE AND LOCATION OF FILTER TRENCHES			
COMPILED JCB	DRN JMW	SCALE	PLAN NUMBER
DIRECTOR OF MINES	CPD	DATE 24.8.76	76-688



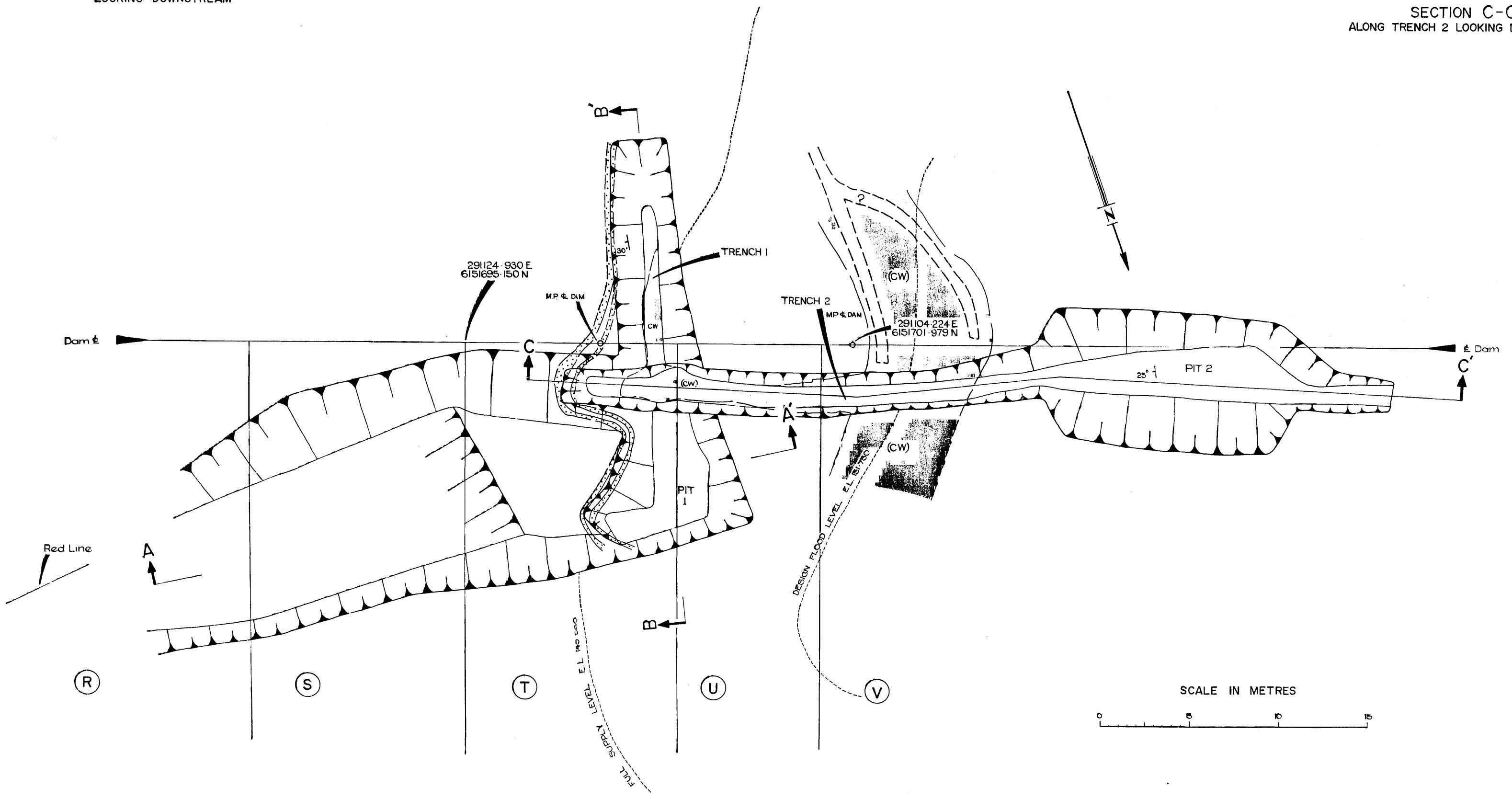
SECTION A-A'
LOOKING DOWNSTREAM



SECTION B-B'
ALONG TRENCH 1



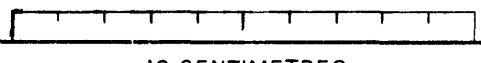
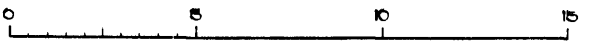
SECTION C-C'
ALONG TRENCH 2 LOOKING DOWNSTREAM



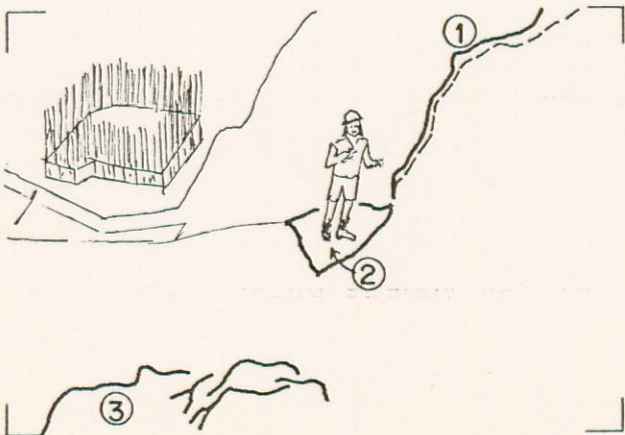
LEGEND

- Transitional Strata
- Massive Quartzite
- Dolomitic Siltstone (Groutable)
- Dolomitic Siltstone (Completely weathered)
- Geological boundary (definite).
- Geological boundary (inferred).
- Cavity 110m extent 40mm x 30mm.
- Strike and dip of bedding.
- Approximate location of small diameter drill holes into quartzite unit.
- Interpretation of soft seams intersected during drilling of air track holes No 1-No 4.
- Proposed location of reverse filter trench.

SCALE IN METRES



DEPARTMENT OF MINES - SOUTH AUSTRALIA			
LITTLE PARA DAM RIGHT ABUTMENT GRCUT CAP GEOLOGICAL PLAN & CROSS SECTIONS			
COMPILED J.C.B.	CHKD J.M.W.	SCALE 1:125	PLAN NUMBER
DIRECTOR OF MINES	CKD	DATE 24-8-76	76-688



NEGATIVE NO. 27073 - March 1974

LEFT BANK GROUT CAP EXCAVATION

1. Hillside stress relief fracture.
2. Dental concrete in excavated seam of weathered dolomitic siltstone.
3. Showing slabby nature of dolomitic siltstone.

FIG. 21



NEGATIVE NO. 26747 - Aug. 1975
RIGHT BANK GROUT CAP EXCAVATION
Showing open bedding plane
persisting downhill. Overlying
quartzite removed by hydraulic
wedge until phase became tight.
Cofferdam and temporary diversion
pipe in background.

FIG. 22

A 1.0 - 6.0 m deep trench was therefore excavated on the right bank grout cap beneath the parapet wall across the grout cap blocks 'T' and 'U' to intersect, inspect and remove completely weathered dolomitic siltstone. Here the dolomitic siltstone was 1.5 m to 3.0 metres thick, underlying 1.0 - 2.0 metres of transitional strata (flaggy quartzite) beneath block 'T' and outcropping beneath the parapet wall.

The occurrence of vuggy quartz veins normally coincided with extensive weathering of the dolomitic siltstone and quartzite; these were removed by pick and shovel or jack hammer.

On the right grout cap alignment large boulders formed by open joints in the quartzite sit upon a quartzite bedding plane and thin clay seams developed along this made removal of the boulders necessary (Figure 22). This was achieved by popping the boulders with small explosive charges or, where within 20 metres of already placed concrete of the Outlet Tower, by use of an hydraulic rock splitter.

On the left grout cap alignment six drainage holes 25 mm diameter lined with slotted PVC piping were drilled into the base of an open hillside stress relief fracture (Figure 21). Seams of completely weathered dolomitic siltstone and weathered material associated with the vuggy quartzite veins of the shear zone were removed and the grout cap realigned in places to avoid areas of persistent open joints and loose slabs.

THE GROUT CURTAIN

A detailed discussion of grout takes used in grouting the curtain and of the various methods of checking its effectiveness is discussed in Part IV: The Grouting Programme and Grout Curtain Investigation.

Early investigation of the proposed grout curtain alignment included diamond drilling and water pressure testing down to 20 metres along the left grout cap. This indicated that fairly low grout takes should be expected. On the right abutment, drilling showed that the quartzite lies above dolomitic siltstone. Also on the right bank grout cap alignment one of the early diamond drill holes put down near block P, was checked by T.V. camera in order to examine an 800 mm core loss near to the contact of the quartzite and dolomitic siltstone. This loss was seen to be restricted to one side of the drill hole, to be limited in width and although persisting laterally beyond the focusing range of the television, appeared to narrow quickly. Therefore at the early stage of assessment only small grout takes were anticipated, providing that all cavities occurring within the grout curtain were similarly small in dimension. However earlier hillside trenching into the transitional strata showed the presence of cavities, having a minimum dimension of 0.5 x 0.5 m x 2 m. The trenching also showed the presence of completely weathered dolomitic siltstone seams. The importance of a successful grout curtain achieving a water tight foundation particularly on the right bank was considered vital and grouting was carried out up to a maximum pressure of 500 KPa.

THE OUTLET TOWER, OUTLET DUCT, AND CONTROL HOUSE

Rock quality of the abutments at Little Para Dam precluded the possibility of a diversion tunnel, as at Kangaroo Creek Dam (Trudinger 1973). Instead, an outlet duct has been constructed passing beneath the rockfill embankment connecting the Outlet Tower to the Control House. An inclined Outlet Tower constructed on the valley wall was also precluded because of the lack of suitable topography at the site.

At Little Para Dam a vertical Control Tower has been built. The tower will exhibit small positive buoyancy when the reservoir is full and therefore the tower base was post-tensioned to the bedrock to resist seismic forces.

Because there is no obvious surface expression of the shear zone which runs up the left abutment it was considered possible that the quartzite could have been displaced by shearing parallel to the bedding plane. In such a case the shear would run along the line of the river, passing beneath the full width of the dam and beneath the Outlet Tower. Diamond core drilling in the creek bed carried out to assess rock quality for the Outlet Tower Foundations gave no evidence of a shear zone and therefore the original location of the shear zone, across the left abutment, was considered proven.

Drill cores from the Outlet Tower foundation proved the presence of quartzite and dolomitic siltstone (Figure 23). The dolomitic siltstone occurs between the base of the Tower and the underlying quartzite and is 2.0 m - 8.0 metres thick. There was no indication of weathered seams, or clay seams, within the dolomitic siltstone which could be compressed during tensioning of the prestressed bars. The quartzite is strong to very strong, fresh and exhibits tight to cemented, vertical to subvertical joint planes, 500 mm - 3 000 mm apart, giving adequate anchorage for the grouted prestressed bars.

During excavation of the Outlet Tower Foundations, stress release of strata was seen in dolomitic siltstone in the left abutment. Individual strata moved out 5 - 20 mm into the excavation, this occurring immediately after blasting. Telltale mortar pads and their measurement showed no further movement over the four months the excavation remained open.

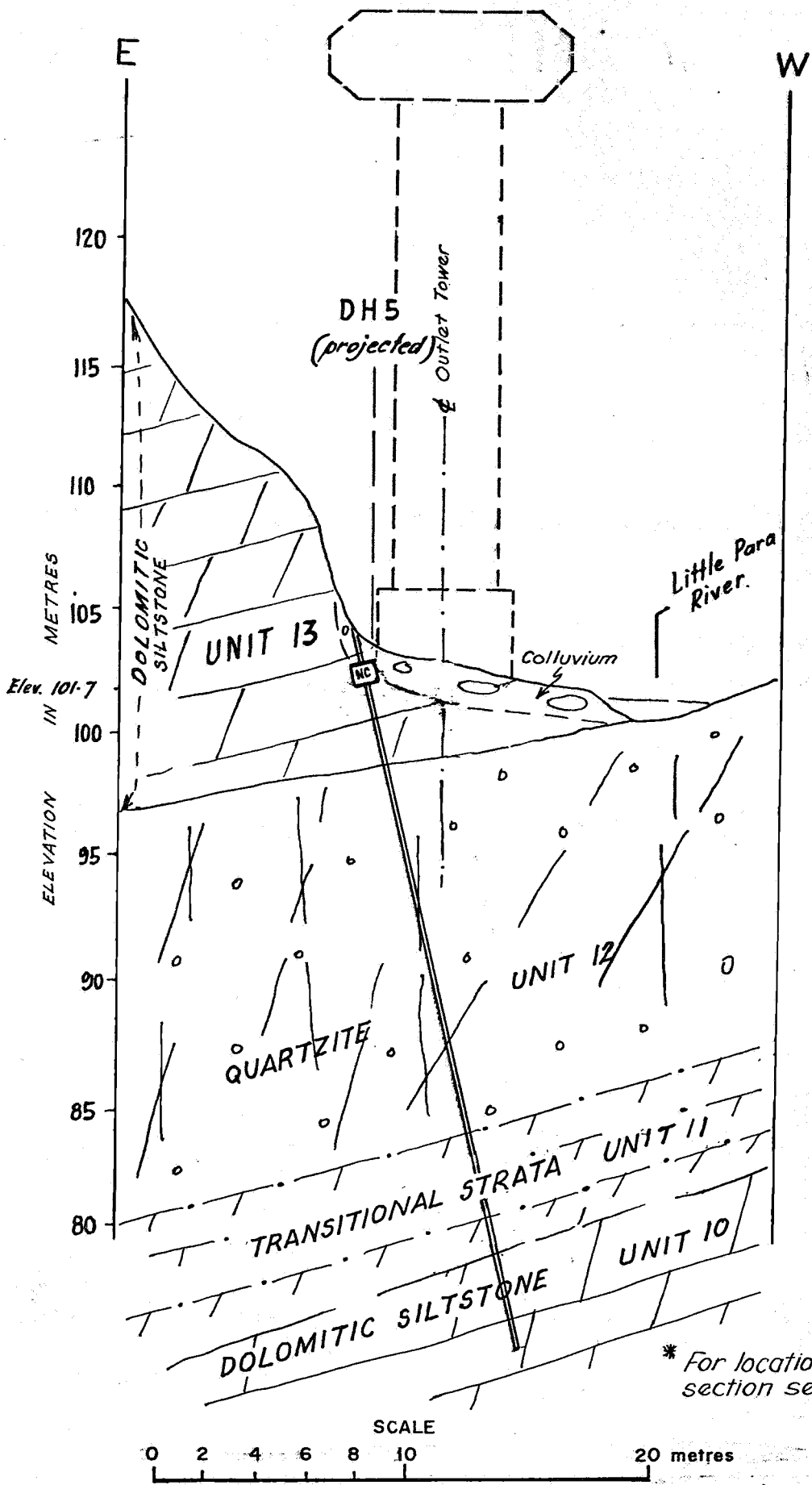
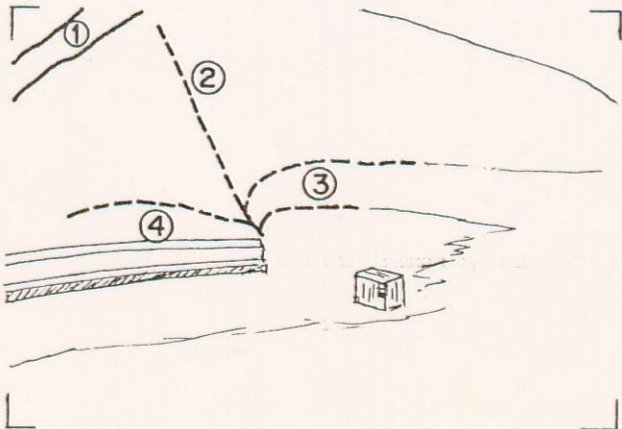
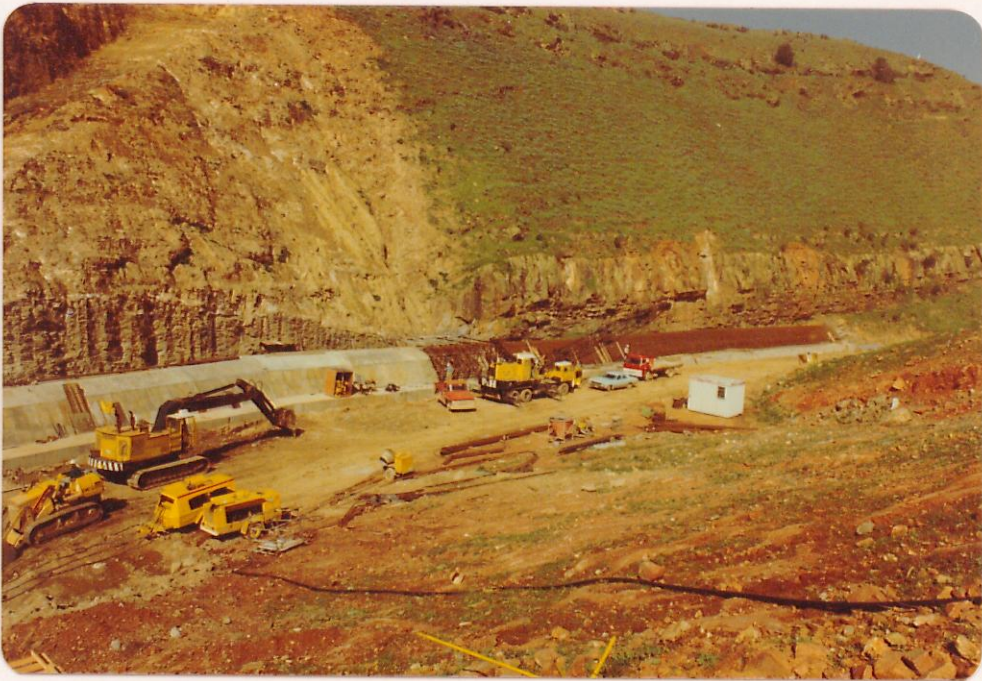


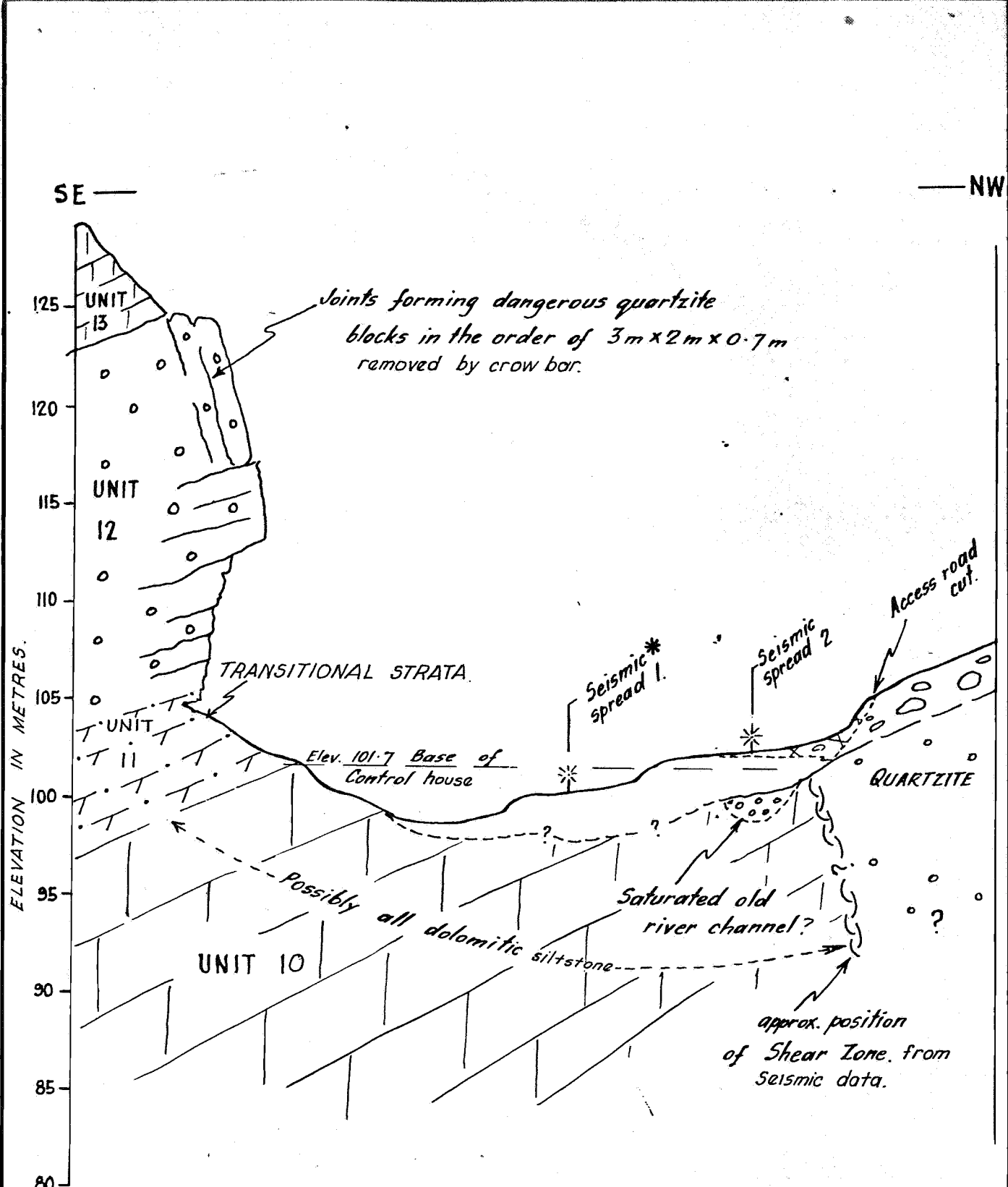
Fig. 23

DEPARTMENT OF MINES AND ENERGY SOUTH AUSTRALIA		SCALE: 1:250
LITTLE PARA DAM		DATE: MAY 1978
COMPILED: J.C.B.	OUTLET TOWER FOUNDATION INVESTIGATION GEOLOGICAL CROSS SECTION	PLAN NUMBER
DRN: B.S.G. CKD:		S13409



NEGATIVE NO. 26751 - Dec. 1975
 LEFT ABUTMENT AND OUTLET DUCT
 1. Left bank group cap excavation.
 2. Shear Zone.
 3. Quartzite (UNIT 12) terminates
 against shear zone.
 4. Gently folded dolomitic
 siltstone.

FIG. 24



* For seismic data see South Australian Department of Mines and Energy report 73/174.
 For location of cross section see Fig. 19

Fig. 25

DEPARTMENT OF MINES AND ENERGY SOUTH AUSTRALIA		SCALE: 1:300 (approx)
LITTLE PARA DAM		DATE: MAY 1978
COMPILED: J.C.B.	CONTROL HOUSE FOUNDATION INVESTIGATION GEOLOGICAL CROSS SECTION	PLAN NUMBER
DRN: B.S.G. CKD:		S13410

Nevertheless, concrete for the Tower base was not placed directly against the excavated face but was formed away from the face and the gap backfilled with rubble to prevent any damage due to further movement. Excavation along the river bed exposed acceptable bedrock for the Outlet Duct Foundation. The shear zone was also exposed and proved to be tight and unweathered and no design modification was thought necessary where the duct traverses the shear zone (Figure 24).

A seismic refraction investigation (Figure 25) immediately downstream of the dam proved shallow bedrock (2.0 - 3.0 metres) beneath the Control House and Dissipating Chamber located at the downstream end of the Outlet Duct. Excavation confirmed an acceptable foundation not affected by the shear zone although the seismic work did show a change in bedrock nature. This was possibly attributable to shearing some 10.0 metres west of the Control House.

THE SPILLWAY

The spillway is located across a ridge of quartzite and dolomitic siltstone. The final position of the spillway is shown on the general site map (Figure 7).

Results of a joint and bedding survey advised a preferred orientation of 095° - 100° for the spillway alignment commensurate with maximum stability of the spillway batters. This orientation could not be exactly followed owing to spillway design requirements for water discharge into the Little Para River and an alignment of 080° - 085° was chosen. Using a scale hydraulic model, the backwater affect created by the quartzite stratum (Unit 9) which crossed the Little Para River at the site of rapids a short distance downstream of the spillway discharge was

studied to see if it encroached upon the downstream toe of the dam. The hydraulic model studies showed that this would not occur.

Three seismic survey traverses (Figure 26) were carried out over the area of spillway discharge to ascertain depth to sound bedrock and to ensure there would be no pot-holing beneath the spillway leading to undermining of the left bank cliff face beneath the spillway lip and downstream of the embankment rockfill. The seismic work proved competent rock at shallow depths (1.0 m - 5.0 m) spillway.

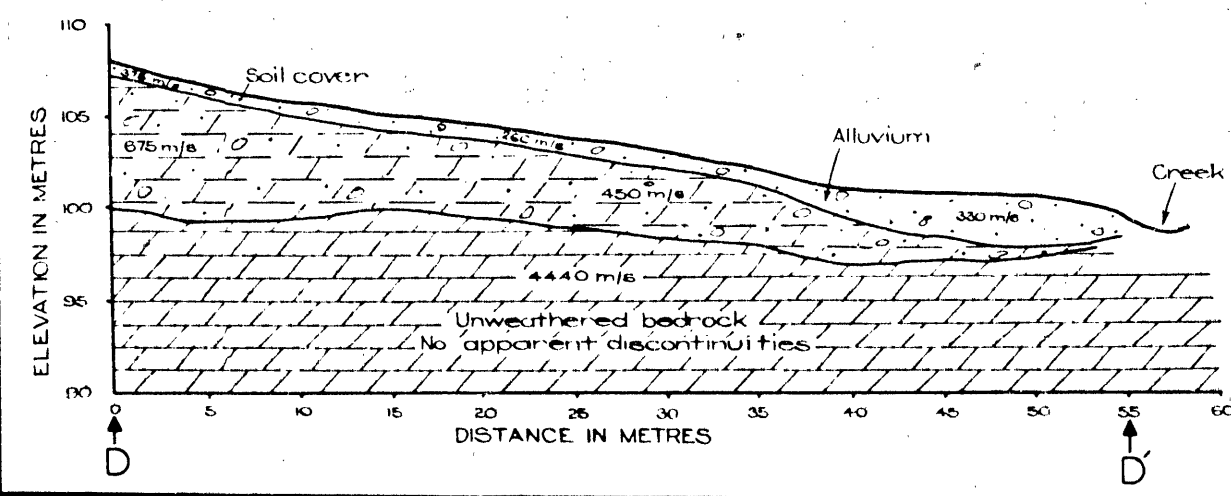
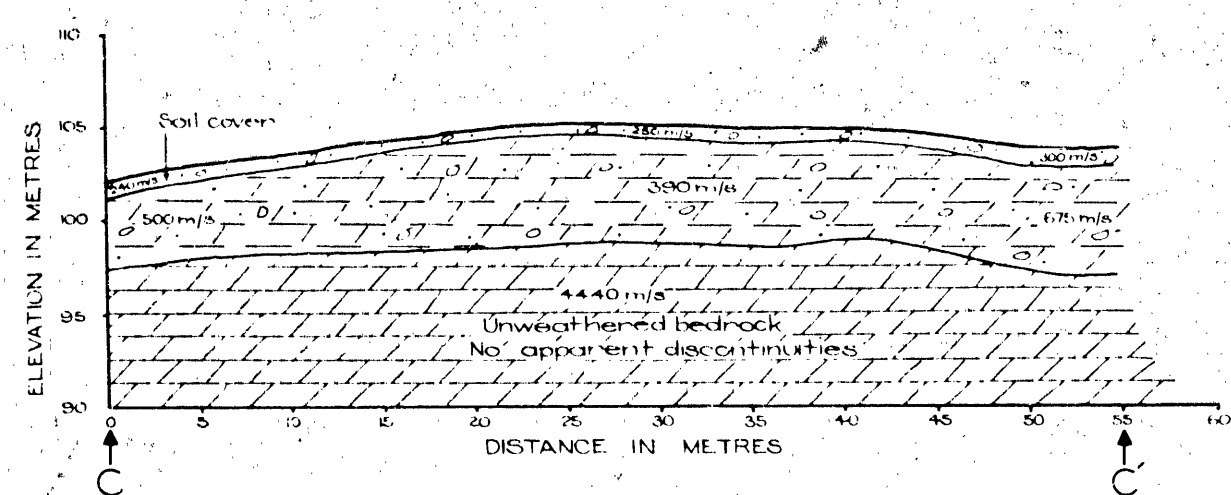
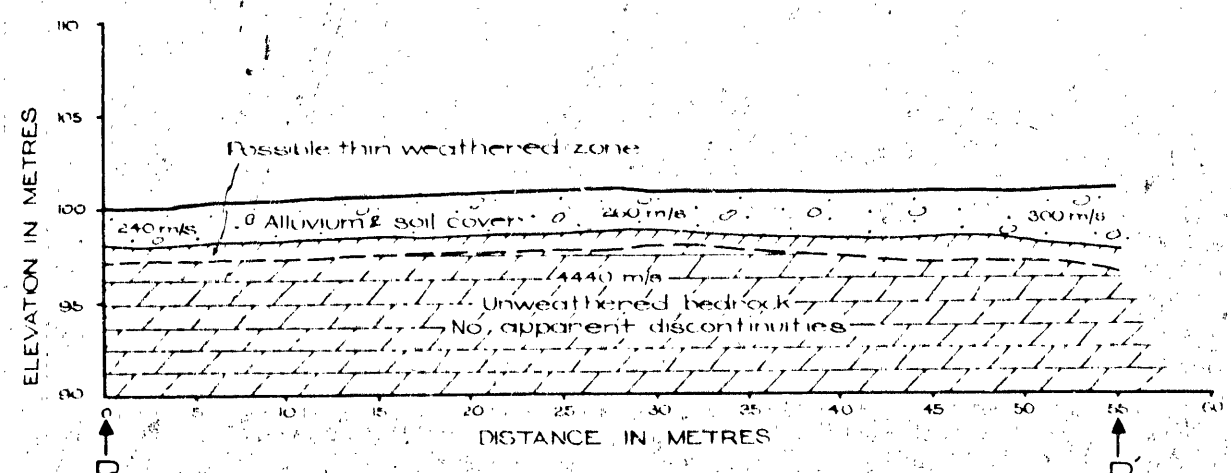
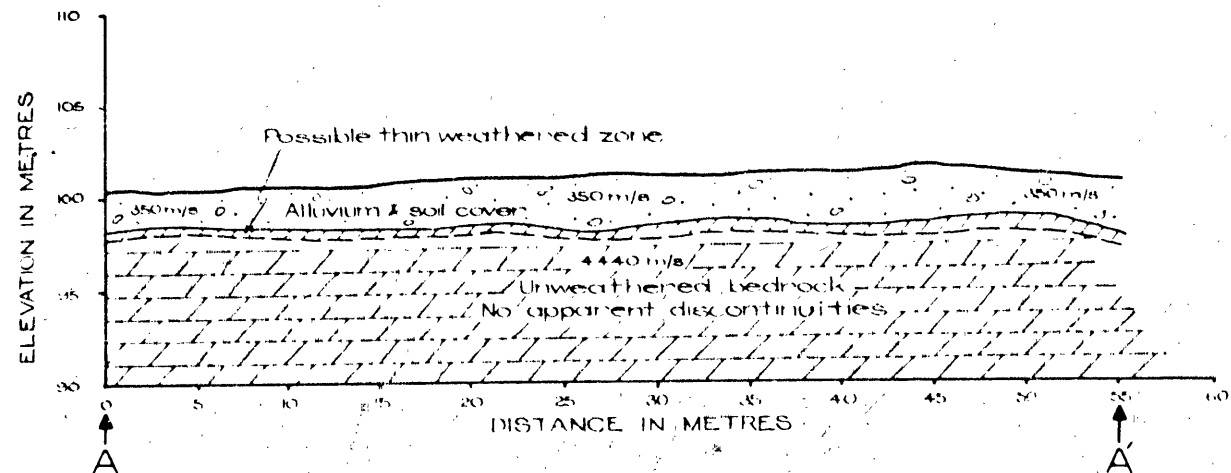
The alignment of the Spillway was chosen to allow discharge of flood waters straight into the river in this area of proven shallow bedrock. This discharge direction also minimises the amount of spray reaching the all-weather access road on the opposite right bank hillside.

During Spillway construction the spillway floor and channel walls were mapped, (Figure 27). Particular attention was paid to seams of completely weathered dolomitic siltstone requiring dental or drainage treatment to prevent erosion and possibly instability.

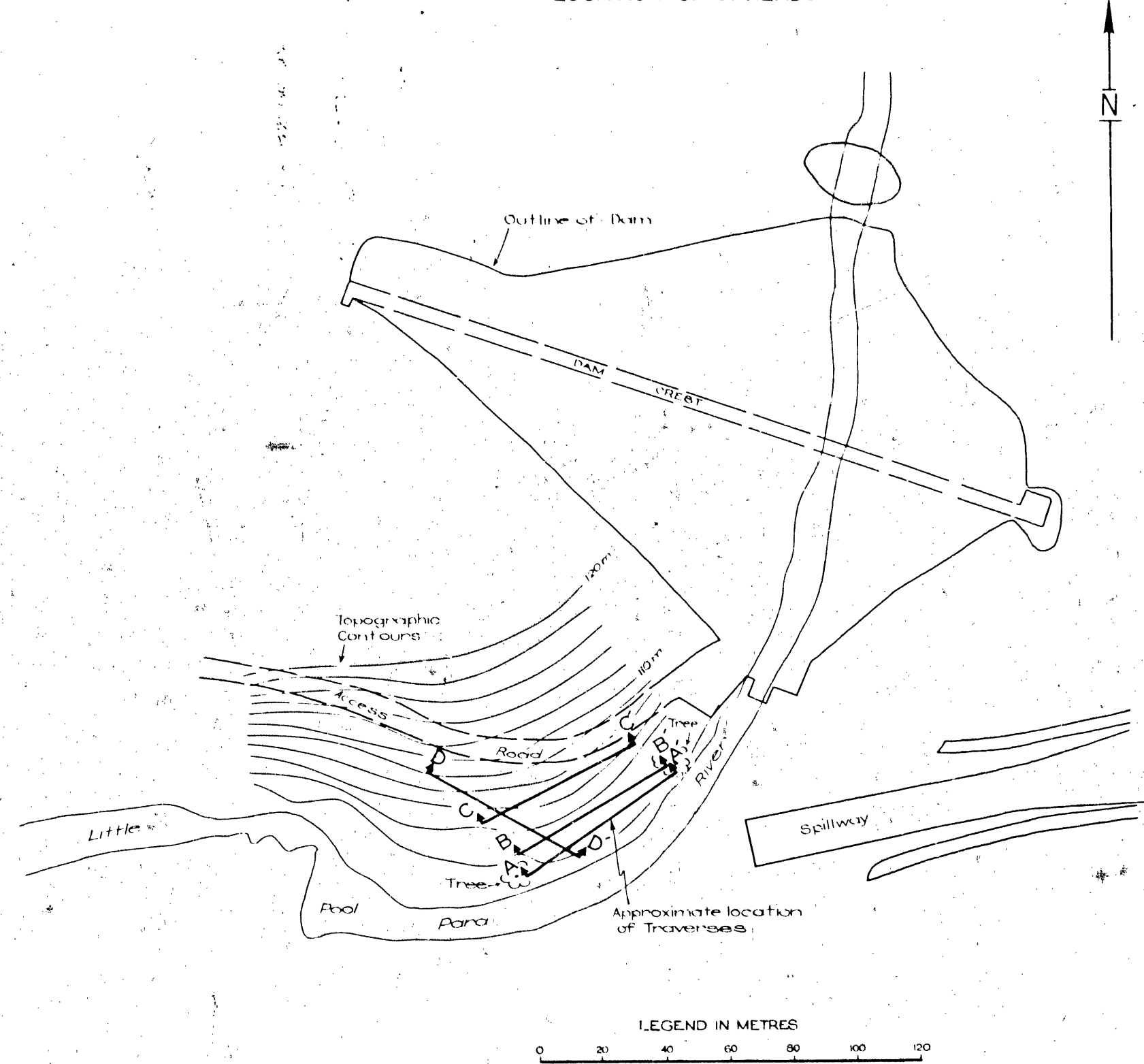
Unstable boulders along the top of the spillway excavation were either removed or stabilized by using grouted dowel-pins. The quartzite cliff beneath the lip of the ski jump was strengthened by using 3.5 metre long rock bolts at 1.5 metre centres and tensioned to a maximum of 890 newtons (250 foot lbs torque).

Two diamond drill holes proved strong competent quartzite bedrock (Unit 12) beneath the base of the ski-jump. The flip bucket at the base of the spillway ski-jump was located to take advantage of this quartzite which has sufficient strength to resist resultant downward forces during Spillway discharge.

SEISMIC SECTIONS



LOCATION OF SPREADS



LEGEND

- Alluvium and soil cover
- Weathered dolomite/colluvium
- Dolomite

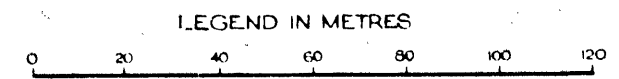


Fig. 26

DEPARTMENT OF MINES - SOUTH AUSTRALIA			
LITTLE PARA DAM SEISMIC REFRACTION SURVEY SPILLWAY DISCHARGE AREA			
GEOPHYSICAL SERVICES SECTION	R. Nelson GEOPHYSICIST	Compiled RN	Scale:
		Date: 29-4-75	
Director of Mines		Dra. JW Cl. A. I.	Drg. No. 75-462

Hillside pressure relief fractures. Up to 20mm lateral displacement of presplit drill holes near chainage 100m. Also open joints (5mm - 30mm) and displaced blocks near chainage 105m. Removal by blasting & barring.

FLAGGY QUARTZITE
Mica development on cleavage planes. Joints iron stained, curvi-planar, uneven. Closed to open up to 3mm.

Stable, loose blocks 1.0m x 1.0m x 0.50m max moderately strong - mod weathered dolomite.

Unless shown otherwise -
QUARTZITE is pale grey/blue, fresh - slightly weathered, strong - very strong, massive or forms unit blocks from 300mm x 300mm x 20mm - slabs up to 1.0m x 1.50m x 1.0m blocks. Joints tight to open up to 3mm).
bedding, planar - uneven, mainly continuous, rarely clay coated.
DOLOMITE is grey-green, moderately weathered, strong - mod strong, bedding planes tight to open (3mm - 5mm) joints tight to open up to 10mm, iron stained, forming unit blocks from fist size to 500mm x 500mm x 500mm.
Joints bedding, continuous to discontinuous, planar - curvi-planar, smooth - uneven, some clay development (rare).

SPILLWAY RIGHT WALL

Shear / thrust zone 200mm - 300mm wide. Polished cleavage surfaces.

Weathered dolomite up to 200mm wide

Quartzite bedding plane

Shear Zone 0.5m wide completely moderately weathered dolomite

Major joint open 2mm - 4mm, curvi-planar, smooth, continuous, iron stained

Minor shear zone open-closed, up to 4mm thick clay development on curvi-planar surface

SPILLWAY CHANNEL FLOOR

SCALE IN METRES



Hillside fracture tight to open up to 2mm - 4mm wide, planar, uneven, coated in places with iron carbonate

Exposed shear plane passing behind spillway channel face. Mortar pads (a) placed where shown and face covered with cyclone mesh held by dowels

Berm edge absent due to over blasting

SPILLWAY LEFT WALL

WEATHERING SYMBOL	DEGREE OF WEATHERING
(F)	Fresh
(SW)	Slightly weathered
(MW)	Moderately weathered
(HW)	Highly weathered
(CW)	Completely weathered

QUARTZITE GRITSTONE

FLAGGY QUARTZITE

DOLOMITE
SHALY DOLOMITE
DOLOMITE HIGHLY WEATHERED
COMPLETELY WEATHERED

QUARTZ VEINS (Vesicular)

● DH 21 Diamond Drill Hole

Major joint with dip and strike

Vertical joint

Strike and dip of strata

Shear zone

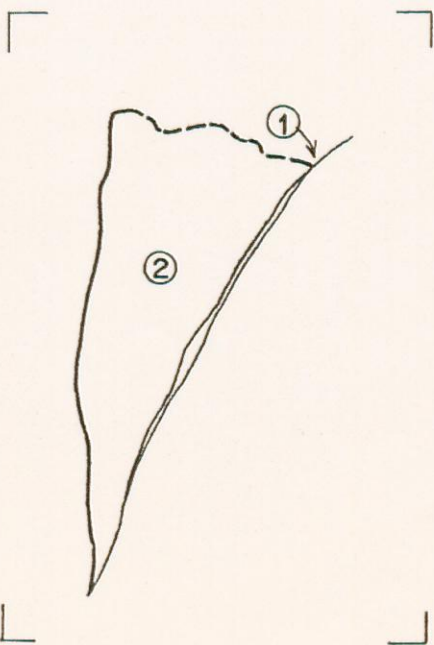
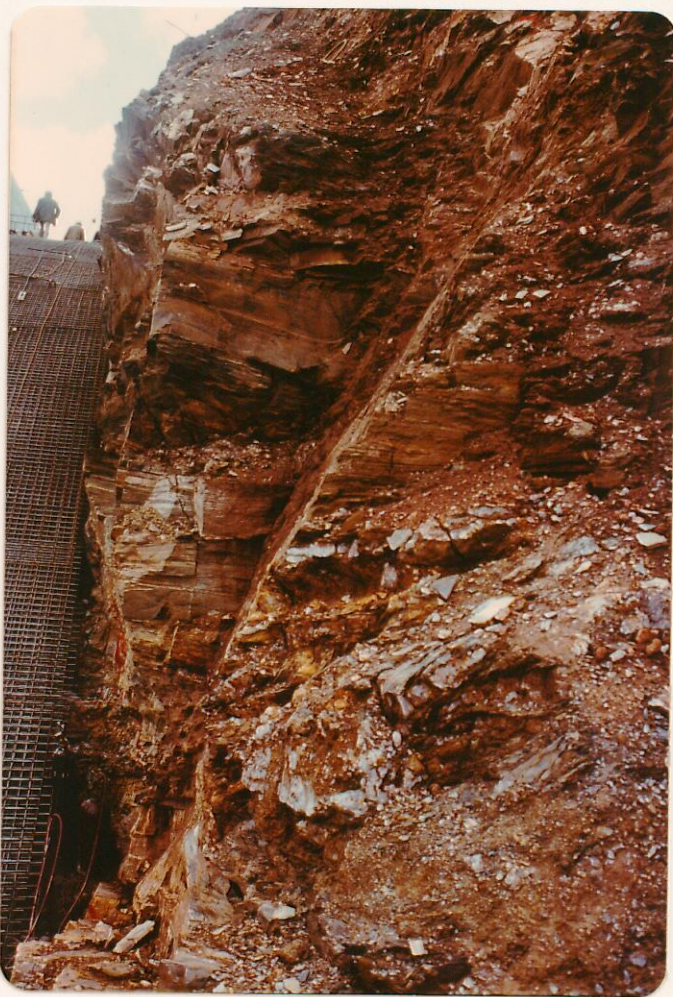
Discontinuity (dominant joint, bedding plane, pressure relief fracture)

Fig. 27

DEPARTMENT OF MINES - SOUTH AUSTRALIA

LITTLE PARA DAM
SPILLWAY
GEOLOGICAL LOG

DESIGNED BY	COMPILED BY	DRAWN BY	SCALE	PLAN NUMBER
	J. Bej.	CRD	1:1	76-929
DIRECTOR OF MINES			DATE	20 NOV 76



SLIDE NO. 12645 - July 1976
SPILLWAY SKI JUMP -
CHANNEL WALL

1. Clay infilled joint day-lighting into the spillway wall.
2. Unstable wedge was covered with cyclone mesh and pinned with dowels.

FIG. 28

Assessment of Batter Slopes

Examination of block sizes of the two types and of the stereogram data (Appendix 3, Figure 63) allowed an initial recommendation to be made for a left hand batter of 75° and for a vertical right hand batter. However, as block sliding could occur on the right hand side along the bedding it was decided to excavate both batters above the channel at 75° . The lower portion of the channel which was to be concrete lined was to be excavated with vertical batters with the concrete to be placed directly against the rock.

The Channel Walls

The rock quality and orientation of defects were examined as each section of the channel was excavated, mapped and assessed for stability.

The face of the excavated vertical walled portion of the channel was inspected for its stability and rock quality to assess whether a free standing or non-free standing concrete wall was required. Where the face was of weathered or loose rock the channel wall was designed as a retaining wall. This was necessary for the full length of the right hand side of the ski jump and for both right and left walls of the flip-bucket. In the case of the ski-jump, excavation was close to the surface and rock quality was not adequate for the channel wall. For the flip bucket, walls of a specific design were required to withstand the discharge thrust and to deflect flood water into the river bed.

A free standing channel wall was also designed for a part of the left side ski-jump where excavation of the channel face had intersected a low angled, clay lined joint plane (See Figure 28). Daily monitoring of small cement mortar pads placed across the joint plane showed no evidence of movement. During construction

the face was pinned and covered with a cyclone fence mesh.

Excavation of the right side channel wall at the top of the ski jump exposed a hillside stress relief fracture. Displacement of strata 5 mm - 12 mm up dip of the bedding plane was observed. Cement mortar pads placed across the fracture showed no evidence of movement and it was concluded that the concrete channel wall could safely be placed against the excavated face.

The main materials quarry supplied the bulk of the embankment rockfill and only a minimum amount of rock was required from the spillway, nearly all of this of zone 3 quality although the quartzite strata traversing the top of the spillway did provide some zone 4 and zone 2 rockfill.

THE QUARRY

Investigation for a suitable quarry site ran concurrently with the investigation for the dam site; altogether five quarry sites were inspected. The first three were rejected because of unacceptable rock quality and the fourth on aesthetic grounds because the proposed site was at the top of a prominent hill. The final site chosen was towards the base of this hill but at a lower level, being less obvious from the public lookout and providing good quality rock for Zones 2 and 4. The site is conveniently situated in terms of elevation and distance from the dam for the water treatment works which will be sited within the quarry.

A fracture survey was carried out over the quarry area to assist in the design of safe batters and to establish the safest excavation sequence. The survey is discussed in Appendix 3.

Included in the same appendix is a profile of the quarry summarising the main features of the survey. (Figure 62).

Rock Quality and Quantities

Surface mapping and the results of two diamond drill holes indicated that although the main bulk of the material in this site would be dolomitic siltstone the presence of a quartzite stratum (Unit 9) thickened to twice normal by folding, would supply the required amount of zone 4 and zone 2 material. Calculations showed that there would be sufficient quantities of dolomitic siltstone to supply nearly all the amount of zone 3 required for the rockfill embankment.

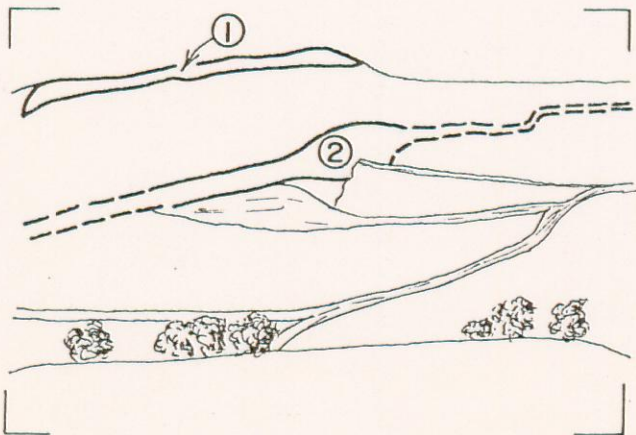
Quarry Excavation and Initial Fracture Survey

The folded quartzite stratum (Unit 9) which traverses the quarry site affected batter stability during excavation of the quarry and for this reason two fracture surveys were carried out.

The first survey assessed the short term stability during the period of excavation and the second survey the long term stability of batters completed (Appendix 3, Figure 55) to ensure the safety of the water treatment structures to be built on the two main berms at EL 110 and EL 120. (Figure 29).

A safe sequence for quarry excavation was suggested as being:

1. Removal of large unstable blocks in quartzite, (UNIT 9 & UNIT 12). For aesthetic reasons this was to be kept to a minimum where UNIT 12 formed a sky line.
2. Excavation of UNIT 9 along the central part of the quarry main face down to 2 - 3 m depending to what depth the folded strata which dips into the quarry is completely removed.



NEGATIVE NO. 27513
April 1976
QUARRY AND WATER TREATMENT WORKS
1. Quartzite UNIT 12
2. Quartzite UNIT 9 thickened
by folding.

FIG. 29

3. Commence excavation of dolomitic siltstone from western end of the quarry, working eastwards.

The main fractures in the quarry area are the bedding and the near vertical joints. Both fracture surfaces may be fresh, or lightly iron stained, planar to curvilinear, uneven to smooth. The main fissile plane is the cleavage which deviates from the true bedding plane by only 2° or 3° and differs from the jointing in being continuous and does not show clay development upon its surface.

Quartzite blocks sliding into the quarry along folded bedding planes caused the main concern for safety during excavation. Stability and hence site safety improved after removal of the northern limb of the shallow anticline.

Because the bedding dips easterly blocks could be expected to slide out of the batters along the western face of the quarry. Friction tests carried out on dolomitic-siltstone (Appendix 3) proved the possibility of such sliding and an angle of 40° was recommended for the western batters. Vertical batters with 5.0 m wide berms were recommended for the rest of the quarry.

The maximum height of vertical batters is controlled by State Mining Regulations at 15 metres. Boulders rolling down an angled surface could overshoot the berms and damage the water treatment works. For this reason vertical batters were preferred and small unstable wedges allowed to fall onto wide berms. A low safety barrier is to be erected adjacent to the water treatment works to intercept any rolling boulders. The design of the fence and ditch excavated at the foot of the berm can be calculated to give maximum safety to the water treatment works (Fookes, et al., 1976). At this site restricted space demands a narrow deep trench and a 3 m high safety fence. The size of the quarry was restricted by topography and vertical

batters assisted in limiting the areal extent of the quarry and in reducing the volume of material excavated.

THE EMBANKMENT

The 54 metre high embankment has three rockfill zones (Figure 12). Zones, 1,2 and 4 are free draining, designed to channel water from the concrete face of the foundation away from zone 3, the main mass of the embankment. The design criteria for each zone is shown in Figure 12.

Zone 6 lies above and around the Outlet Duct and serves to reduce stresses on the duct resulting from the weight of the overburden. Zone 5 is a zone of poor to moderate rock quality placed over the foot of the parapet wall and upon which runs the dam axis access road.

The bulk of the embankment, moderately strong, moderately weathered dolomitic siltstone was placed wet and compacted with four passes of a 10 tonne vibrating roller.

Settlement of the embankment during and after construction was measured using hydraulic settlement gauges. Deflection of the embankment was also measured (Appendix 2).

IV THE GROUTING PROGRAMME AND GROUT CURTAIN INVESTIGATION

INTRODUCTION

THE GROUTING PROGRAMME

INVESTIGATION OF THE GROUT CURTAIN

Table 8: Summary of Trial Tests.

Table 9: Trial Water Pressure and Isotopic Grout Tests.

Table 10 : Main test on Block S Hole SP95.

Table 11: Main test on Block S. Hole SP116.

WATER PRESSURE TESTS ON THE COMPLETED GROUT CURTAIN

Table 12: Summary of Check Hole Grout takes.

DISCUSSION AND SUMMARY

THE GROUTING PROGRAMME AND GROUT CURTAIN INVESTIGATION

INTRODUCTION

A double grout curtain 21 metres deep was cement grouted in three stages of 7 metres each using a downstage non-packer technique at maximum pressures of 110 KPa, 250 KPa and 500 KPa for the first, second and third stages respectively. This method of grouting using a grout nipple on a stand pipe proved time consuming but reliable & effective. In the area of Blocks M & N uplift of the rock of 1 to 4 mm occurred and here the stage depths and pressures were reduced and upstage grouting with a packer used in combination with downstage grouting. Details of the grouting procedure are discussed in Appendix 1. The grout curtain passed through quartzite, the transitional strata (interbedded flaggy quartzite and dolomitic siltstone), and dolomitic siltstone which in places is completely weathered immediately beneath the transitional strata.

Primary grout holes were first drilled at 6.0 m intervals and then repeatedly halving the distance for subsequent secondary, tertiary and quaternary holes. Water pressure testing of the foundations was carried out before and after grouting of the curtain. During the construction period a research programme was undertaken to test the effectiveness of the grout curtain, particularly across the areas where seams of weathered dolomitic siltstone occur. Geophysical measurements and isotopic grout methods were used to see if it was possible to differentiate between ungroutable and groutable foundation rock.

THE GROUTING PROGRAMME

Curtain grouting at Little Para Dam consisted of drilling two rows of holes (45 mm diameter) through the grout cap. The effective depth of this double curtain due to the natural

slope of the grout cap and the inclination of some of the holes varied from 8 metres to 20 metres but an average was close to 20 metres.

The Grouting started at the bottom of the valley and proceeded up both abutments with the downstream curtain drilled and grouted 15 m ahead of the upstream curtain. In this way the upstream curtain formed a check on the closure of the downstream curtain.

On the basis of known orientations of joints, bedding planes and shear zones it was initially decided to make all grout holes vertical. This would allow intersection of a maximum number of fissures and obviate the need to design a cross over arrangement, normally necessary when two differently inclined sets of grout holes meet.

Because of the steepness of the left hillside it was later decided to angle the grout holes into the hillside between Blocks 'F' and 'A', drilling them at an angle of 30° to the vertical and on a bearing at right angles to the dam axis. This geometry allowed use of normal grouting pressures without risking uplift of the adjacent hillside. However the effective depth of this angled part of the grout curtain was only 8.0 metres and caused concern as seams of completely weathered dolomitic siltstone persist to depth beneath Blocks A and B. An upstream row of vertical grout holes was therefore drilled to an effective depth of 15 metres on Blocks A and B. Low grout takes between Blocks F and C indicated that a third row of vertical holes was not warranted and that the two rows of angled grout holes would suffice.

From a choice of suspension, liquid or foam (aerated emulsion) grouts it was decided to use an unstable suspended grout:cement. The choice was based on experience from previous dam sites and on the assumption that penetration of fissures and not the filling of large cavities would form the major grouting (Cambefort 1977).

Pressures adopted for grouting were calculated on maximum pressures allowable before uplift of the overburden and grout cap could occur. In fact some uplift of 2 mm - 4 mm did occur half way up the right bank grout curtain and grouting pressures had to be lowered from a maximum of 500 KPa down to 350 KPa and the number of stages decreased from 3 to 2. Also taken into consideration were minimum grouting pressures allowable, calculated on the hydrostatic pressure exerted by the head of water at full reservoir. From this the grout cap thickness was calculated.

The presence of completely weathered seams of dolomitic siltstone indicates that grouting in these areas could be achieved by penetration after dilation of the strata ("claquage" see Cambefort 1977) rather than by direct penetration. The nature of the weathered seams made impregnation grouting virtually impossible.

Evidence that claquage grouting took place was when several boreholes showed back-flow of grout up the grout hole upon relaxation of grouting pressures. Subsequent drill coring in this area through the weathered seams showed nil to very little grout, also inspection of core from angled grout curtain check holes showed the presence of grout no further than 250 mm distant from the nearest grout hole.

The effectiveness of dilation and penetration grouting is related to stresses exerted upon the sides of the boreholes and the same pressures in smaller diameter grout holes may have increased grouting effectiveness. At higher pressures care would have had to be taken not to uplift the overlying strata.

Low grout take was not interpreted as unsuccessful grouting but simply an indication that in the main the foundation did not require grouting and water loss would be minimal.

However, laboratory tests revealed the dispersive nature of some of the weathered dolomitic seams leading to concern that leakage of water through the weathered seams may eventually cause dispersion and allow piping to take place.

Grout on the site always commenced with a 1:5 mix of cement to water unless prior water testing of the grout hole at grouting pressures showed high losses when a start mix of 1:3 was used. The disadvantage of commencing with a dilute grout, particularly in areas of the weathered seams is the possibility of sealing the hole and greatly reducing the effectiveness of subsequent grouting.

It may be argued therefore that more effective grouting may have been possible by using small diameter grout holes, higher pressures, and thicker initial grouts. However, the results of the grouting programme show that closure was achieved on most grout holes and where refusal was not achieved holes were brought closer together (in some cases as close as 750 mm) until closure was achieved.

INVESTIGATION OF THE GROUT CURTAIN

Geophysical measurements, Self Potential and Point Resistance, were used on the right bank grout curtain beneath grout cap Block 'M' in an attempt to assess the groutable nature

of the bedrock, in particular at depths where the grout curtain passes through the transitional strata. Trenching at the top of the right abutment exposed completely weathered strata and because of this the grout curtain was also investigated beneath Block 'S'. This was done by using isotopic grout during the normal grouting programme and locating grouted horizons using a geiger probe.

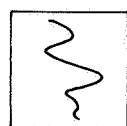
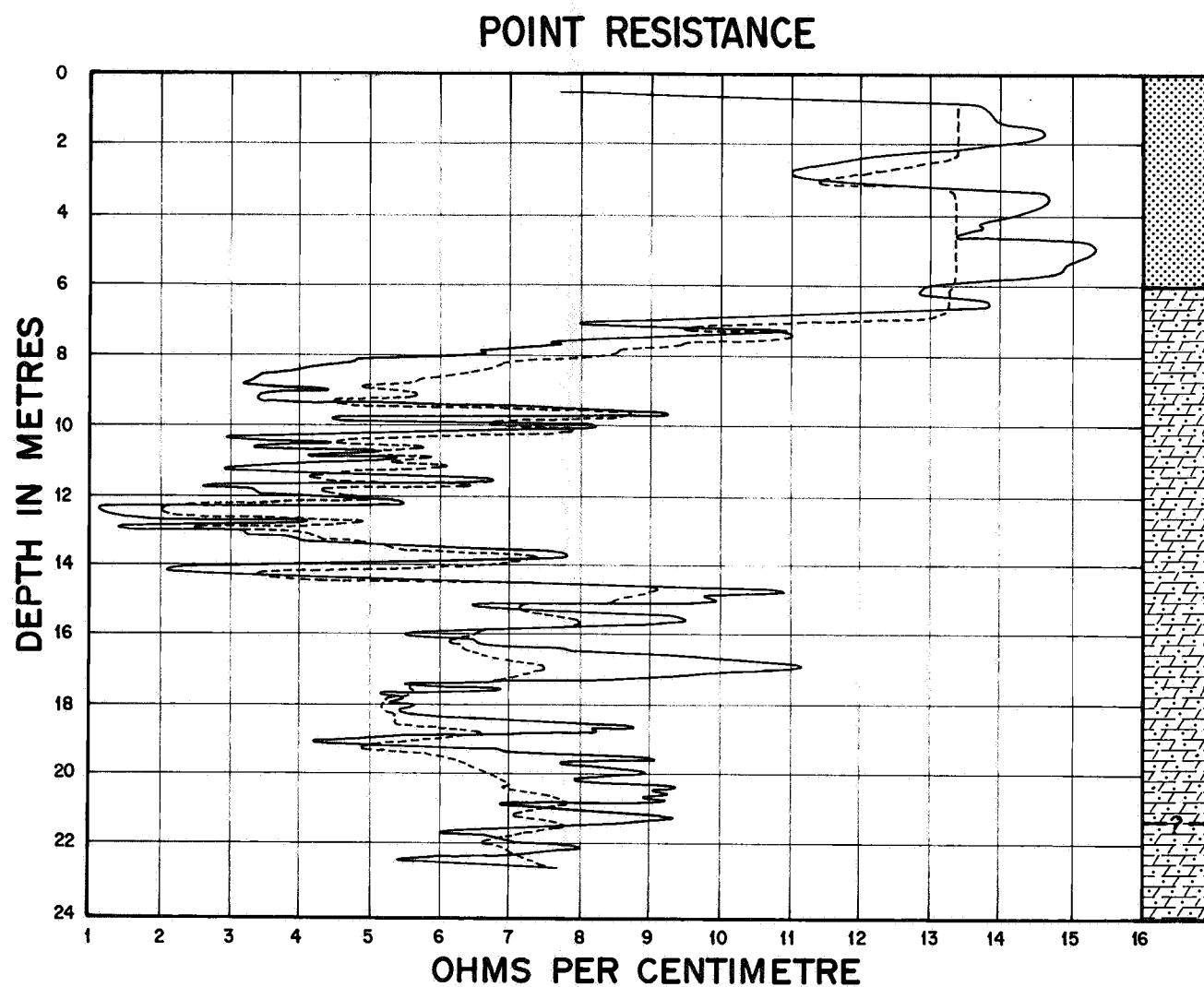
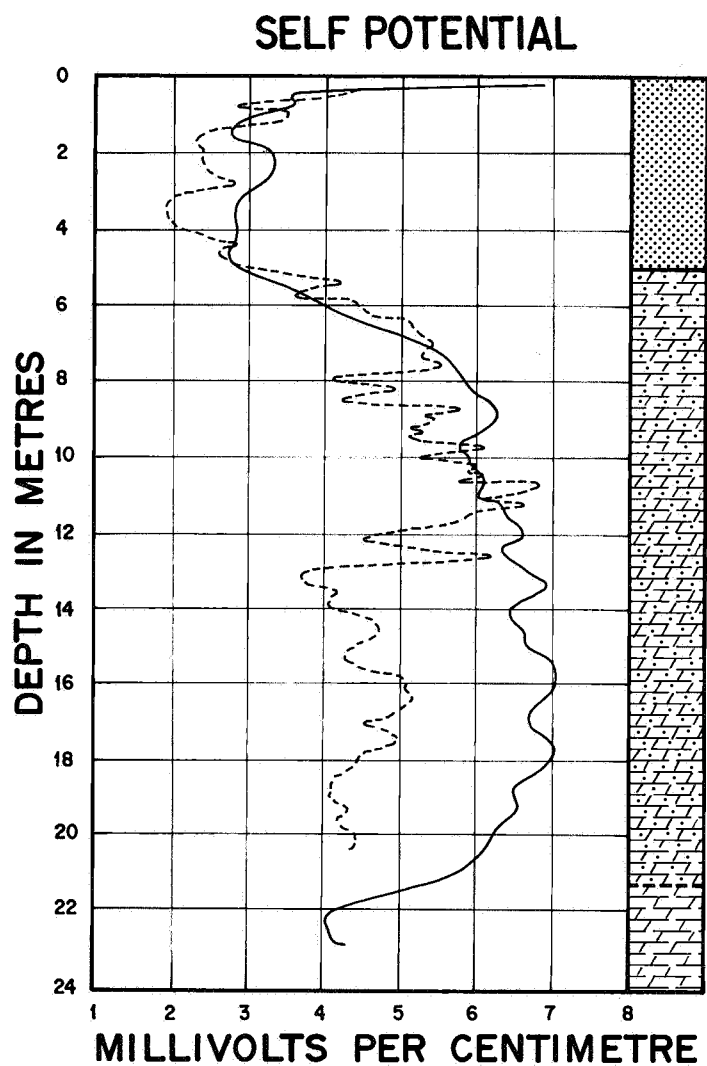
Self Potential and Point Resistance Methods

Readings taken down grout hole MP 40 on grout cap Block 'M' before and after grouting are shown in Figure 30. Differentiation between the quartzite and the transitional strata was possible using both methods; the point resistance more so than the self potential.

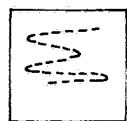
The effect of grouting on the point resistance graphs is to reduce the maxima and minima particularly the maxima as grouting of the open fractures increases the conductivity of the rock hence producing lower resistance readings. The difference between the maxima and minima after grouting is more marked between 8 and 14 metres within the transitional strata.

Grouting reduced the value of current measured during the self-potential test; ungrouted areas showing as maxima on the graphs. Although both graphs delineate narrow bands of varying values of self-potential or point-resistance the uniqueness of each band is questionable.

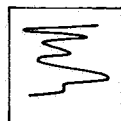
Unfortunately, construction work made it impossible to repeat the tests on adjacent grout holes but the indication is that reference of data from grout hole to grout hole using these two methods is too unreliable for making detailed assessments of the grouted strata.



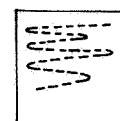
S.P. readings before grouting MP40



S.P. reading after grouting MP40 using "FAILING" 3000' Logger.



Resistance reading before grouting MP40



Resistance reading after grouting MP40 using "FAILING" 3000' Logger.



QUARTZITE



DOLOMITE-FLAGGY QUARTZITE



DOLOMITE



GEOLOGICAL BOUNDARY (Not identified)

Fig. 30

DEPARTMENT OF MINES—SOUTH AUSTRALIA				
LITTLE PARA DAM				
RIGHT BANK GROUT CURTAIN				
SELF POTENTIAL & POINT RESISTANCE READINGS				
ENGINEERING SERVICES	COMPILED: J. C. BEAL	DRN: L. C.	SCALE: AS SHOWN	PLAN NUMBER
DIRECTOR OF MINES		CKD:	DATE: SEPTEMBER '76	76-756

ISOTOPIC GROUT METHOD

The Pilot Programme

The initial method of grout curtain testing used "dyed" water to establish the interconnecting nature of open fractures between grout holes and observation holes. After grouting, the dyed water test was then repeated. The presence of any water in the observation bores was taken as indicating ineffective grouting.

To determine grout travel from the grouted hole towards observation holes isotopic grout was used and its presence monitored by lowering a geiger probe down the open grout holes and observation holes immediately after grouting. Although isotopes have been used to trace the mobility of dam water (Bowen 1975) there appears to be no literature on using isotopes to trace grout movement.

Bromine 82 has a half life of 37.5 hours and radiation (0.78 Mev) is sufficiently strong to enable geiger measurements to be made up to 2 days after grouting. This radio-active isotope was supplied by the Australian Atomic Energy Commission, Lucas Heights, Sydney, in liquified form and forwarded by air freight. The liquid, only a few millilitres, was held in a phial within a screw top cannister; both phial and cannister were wrapped in foil and all transported within a thick lead container. Only an approved agent for the Commission was allowed to handle the isotope. All men involved with the grouting were supplied with pocket dosimeters. During and after the experiment the equipment and areas affected by the grout were thoroughly washed down and radiation levels checked. All readings were extremely low and at no time constituted a health hazard.



NEGATIVE NO. 27513
April 1977
Water pressure testing -
Grout CAP BLOCK S
Canvas tape on drum lowered
down observation holes.
Note Rhodamine 'B' dye stain

FIG. 31

The amount of isotope purchased was calculated so as to read 5 millicuries on the morning of collection from the airport. On site it was carefully mixed with water before adding to the grout in 2.5 millicurie amounts.

Trial Tests on Grout Cap Block R

Trial tests were divided into two groups; those tests relating to use of Rhodamine B and those to use of isotopic grout. The tests were carried out to investigate the effectiveness of the dye tracers and to calculate required dye concentrations; to check concentrations of isotope required in the grout and to check the sensitivity of the scintillometer and gamma probe and the maximum period over which monitoring of the isotope is possible.

Trial Tests Using Dye Indicator

Because of its proven sensitivity in tracing mobile water (Atkinsen et al 1973; Lockwood 1971 and Smart et al., 1976) the existence of interconnections between grout holes during water pressure testing was established by using Rhodamine B dye. Its presence was indicated on dye sensitive canvas masking tape lowered down the grout hole (Figure 31).

Results of the trial tests are summarised in Tables 8 & 9. Generally it may be stated that six grams of dye placed in the stand pipe of the grout hole and tested over 5 minutes will give a measurable dye concentration where water losses are in the order of 100 litres per minute. Approximate Rhodamine B concentrations in the water after testing for 5 minutes were in the order of 200 milligrams per litre.

Very dilute but still visual concentrations in the order of 3.5 milligrams of Rhodamine B per litre are sufficient to permanently stain the canvas tape, suspended down all the test holes.

TEST	TYPE	PURPOSE	RESULTS
1	LABORATORY TEST	To assess powdered and granulated activated charcoal and stick charcoal as dye tracers in varying strengths of dye solution (Rhodamine B)	<p>Powdered charcoal held in dialysis tubing adsorbs dye too slowly.</p> <p>Low adsorption figures for granulated charcoal held in terylene bags probably due to wetting problem.</p> <p>One stick charcoal sample gave adsorption figure 10-50 times higher than other charcoals.</p>
2	LABORATORY TEST	Compare dye adsorption of granulated to stick charcoal.	Stick charcoal very sensitive. Granulated type reactive but over a longer period of time.
3	FIELD TEST	Water pressure test grout hole RP 75 Check water movement to adjacent holes by dye tracers.	Low adsorption values; poor connections between observation holes.
4	FIELD TEST	Water pressure test grout hole RSE 2 Poor connections to observation holes.	Slightly higher values recorded but still poor connections. Obvious staining on canvas masking tape suggested possible use of tape as cheap dye tracer. See Test 7.
5	FIELD TEST	Grout borehole RTE 3 using Br 82; measure radiation with scintillometer probe. Compare to previous geophysical tests check site radiation safety levels.	<p>2.5 millicuries mixed in 200 litres of 5:1 grout measurable upto 3 - 5 days without background interference.</p> <p>Pocket dosimeters showed very low exposure levels.</p>

TABLE 8 - SUMMARY OF TRIAL TESTS

TEST	TYPE	PURPOSE	RESULTS
6	FIELD TEST	Assess effectiveness of Grouting using dye water pressure test and stick charcoal dye tracer.	Stick charcoal has adsorption limits. Eroded clay seams led to interconnections by-passing grouted hole. Test inconclusive.
7	LABORATORY TEST	Assess sensitivity of canvas tape to varying concentrations of dye solution.	Discolouration of tape very sensitive visible to 3.5 milligrams per litre dye strength; acceptable for field use.
8	FIELD TEST	Measure background gamma radiation on Block S using scaler Geiger probe.	More convenient than the scintillometer equipment but slower and less accurate; satisfactory for the tests; background values upto 3 c.p.s.

TABLE 8 CONTINUED

Water Pressure Test:Losses

BOREHOLE	WATER PRESSURE	TIME	LOSS	TOTAL LOSS	COMMENTS
RP 75	110 kpa "	5 mins. 5 mins.	15 litres 10 litres	25 litres	# Half Isotope used for testing each borehole. A total of 5 millicuries of Bromine 82 used.
RSE 2	110 kpa (no pressure recorded)	10 mins. 2 mins.	28 litres 162 litres	188 litres	* Volume of grout (5:1 mix) in 1st stage length of grout hole is 11 litres. f Calculated from $\frac{31 \times 0.18}{26.5}$

Grout Test:Losses

BOREHOLE	STAGE DEPTH (m)	WATER CEMENT	PRESSURE	TIME (MINS)	LITRES GROUT LOST	NETT LOSS: BAGS DRY CEMENT	COMMENTS
RP 75 [#]	9.0	5:1	110 kpa	15	(120 ⁺)		+ Grout lost in delivery hose.
		"	"	15	46		
		"	"	15	17		
		"	"	15	15		
		"	"	15	0		
TOTAL:					78 - 11*	0.5 b	
=					67 litres		
RSE 2	9.0	5:1	110 kpa	15	28		
				15	18		
				15	2		
TOTAL					42 - 11	0.2 b ^f	
=					31 litres		

TABLE 9 - TRIAL WATER PRESSURE AND ISOTOPIC GROUT TESTS (BLOCK 'R')

TABLE 10
 MAIN TEST ON GROUT CAP BLOCK S
 GROUT HOLE NO. SP95

WATER PRESSURE TEST		STAGE	GROUT TEST		GROUT CONNECTIONS	GEOLOGY	DEPTH m
DATE	LOSS		LOSS	DATE			
20.4.76	195 litres/5 min. @ 110 KPa	1 7.0 m	0.5 bags @ 110 KPa (i.e. 13.2 litres of dry cement, 5:1, or 0.013 cu.m.).	14.7.76		Grout Cap.	2
13.7.76	104 litres/5 min. @ 450 KPa						4
26.7.76	100 litres/3 min. @ 250 KPa	2 7 - 10.0 m	5.8 bags @ 250 kPa (0.15 cu.m.) 5:1 thickening to 2:1	27.7.76	To XS4	T-T 2 T-T T-T T-T 3	6
30.7.76*	100 litres/3 min. @ 110 KPa						3 10.0 m - 21.0 m
						4 5?	10 12 14 16
							18 20

COMMENTS

LEGEND: 1. Quartzite; 2. Transitional Strata; 3. Transitional strata associated with weathered dolomitic siltstone. 4. Dolomitic siltstone. 5. Highly-Completely weathered dolomitic siltstone. Owing to water loss @ 10.0 m, third stage water pressure test (10.0 m - 21.0 m) continued after grouting second stage (7.0 m - 10.0 m).

3rd stage grouting did not use isotopic grout. All isotope used for 3rd stage grouting SP116.

*Note high water loss and low grout take. Clay seam reported by driller at 15.20 - 16.80 m.

TABLE 11
 MAIN TEST ON GROUT CAP BLOCK S
 GROUT HOLE NO. SP116

WATER PRESSURE TEST		STAGE	GROUT* TEST		CONNECTIONS	GEOLOGY +	DEPTH m
DATE	LOSS		LOSS	DATE			
13.7.76	150 litres/5 mins	1 0.0 m - 7.0 m	0.1 bags @ 110 KPa (0.003 cu.m.) 5:1 mix.	14.7.76		Grout Cap 1 T T T T 2 T	2 4
26.7.76	110 litres/5 mins @ 110 KPa 10 litres/5 mins @ 250 KPa	2 7.0 m - 14.0 m	1.0 bags @ 250 KPa (0.027 cu.m.) 5:1.	27.7.76	to XS3	T T T T 3 T T T T	6 8 10
30.7.76	42 litres/5 mins @ 110 KPa 15 litres/5 mins @ 250 KPa	3 14.0 m - 21.0 m	16.4 bags @ 250 KPa (0.43 cu.m.) 3:1 mix thickening to 1:1.	2.8.76	to XS7, OB6, OB7, AG2, OB8. XS 9	T 4 T T T T T T T T T 5? T T	12 14 16 18 20

COMMENTS

+ See table 10A for legend.

* Four applications of isotope used i.e. 2.5 millicuries per 108 litres dry cement.

Driller reports water loss between 18.30 m-18.90 m.

The self adhesive tape is cheap, and easy to use and is sufficiently sensitive for the purpose of establishing the presence of dye bearing water.

It was found that stick (sketching) charcoal was sensitive to the dye, cheap and easy to handle. However, the charcoal needs to be packaged before attaching to the nylon line and an analysis is required before results of the test are known. The limiting disadvantage is that no matter what the strength of the dye solution, the stick charcoal appears to constantly give values in the range 20-80 milligrams per litre. Analysis results therefore do not indicate the varying strengths of dye solution, only the presence of Rhodamine B.

In summary, plain, canvas tape is sufficiently sensitive to show the presence of Rhodamine B. If the dye is adsorbed by the clay content of any weathered seam then the tape is clean but has a wetted appearance and can still be used to prove the presence of a water connection. (Figure 31)

Trial Tests Using Isotopic Grout

In general 2.5 millicuries of Bromine 82 placed in 200 litres of 5:1 grout is sufficient to allow gamma values in the order of 500 c.p.s. to be recorded immediately after grouting and 120 c.p.s. to be recorded forty eight hours after grouting. These counts were recorded using a scintillometer type probe.

Because of its length the scintillometer probe (30 m.m. diam.) became stuck in most of the grout holes (44 m.m. diam). A geiger probe was tried and proved sufficiently accurate to detect areas of grout take. The equipment uses a 6 volt battery and can be kept on site in readiness for use required. The probe was small enough not to stick in any of the holes tested.

The geiger probe gave background values in the order of 2 - 3 c.p.s. compared to background values of up to 125 c.p.s. recorded by the scintillometer probe. These high counts occurred at depths coincident with a change in rock type from quartzite to dolomitic siltstone which is commonly the site of clay development. It was therefore a necessary precaution when using a scintillometer probe to record presence of isotopic grout within two or three days of grouting otherwise clay seam radiation could mask the grouted seams.

Results of gamma probing compared to earlier tests using self potential and single point resistivity show the former to be more accurate in identifying the "before" and "after" grouting picture. Grout connections between grout holes may be more readily identified (Figure 32).

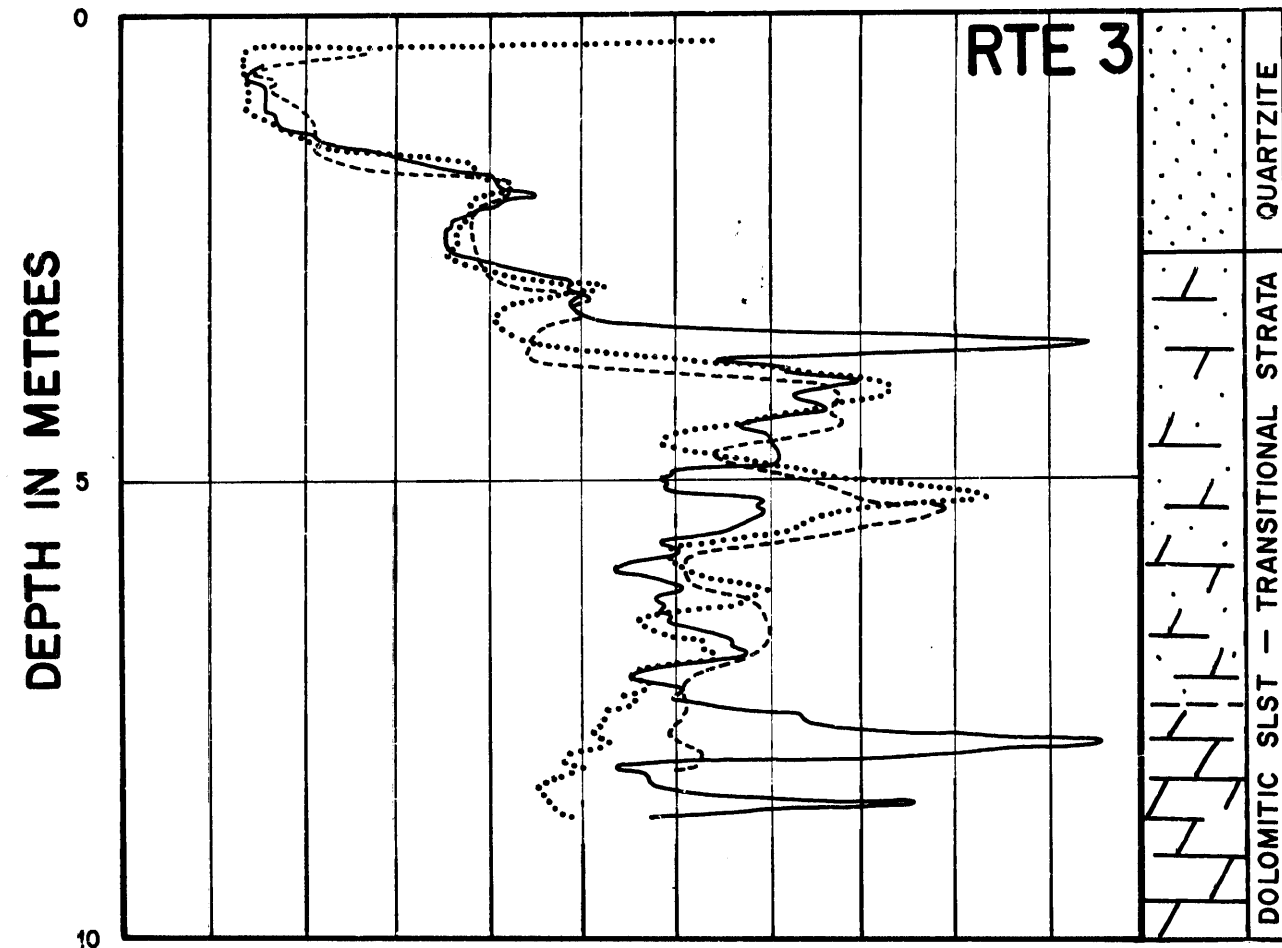
Grouting Test Holes RP 75, RTE and RSE 2

The isotope (2.5 millicuries) was mixed with 200 litres of grout mix (5 parts water to 1 part of dry cement) and pumped into borehole RP 75 after background readings had been taken down the bore hole. The location of all the grout and observation holes are shown in Figure 33.

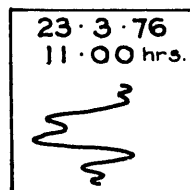
Readings were taken in RTE 3 during and after the grouting of RP 75 to establish positions of grouting connections. Using the remaining isotope (2.5 millicuries) bore hole RSE 2 was then grouted and readings taken immediately afterwards and daily for the next two days. As activity of the isotope weakened readings were taken on an increasingly sensitive scale.

Inspection of the graphs allowed the following to be deduced.

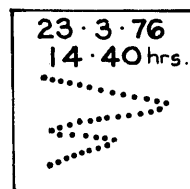
Background readings and results of grouting adjacent holes



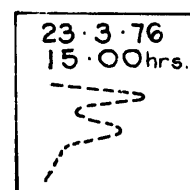
COUNTS PER SECOND
(Each division represents 12.5x100c.p.s.)



Background reading for RTE 3

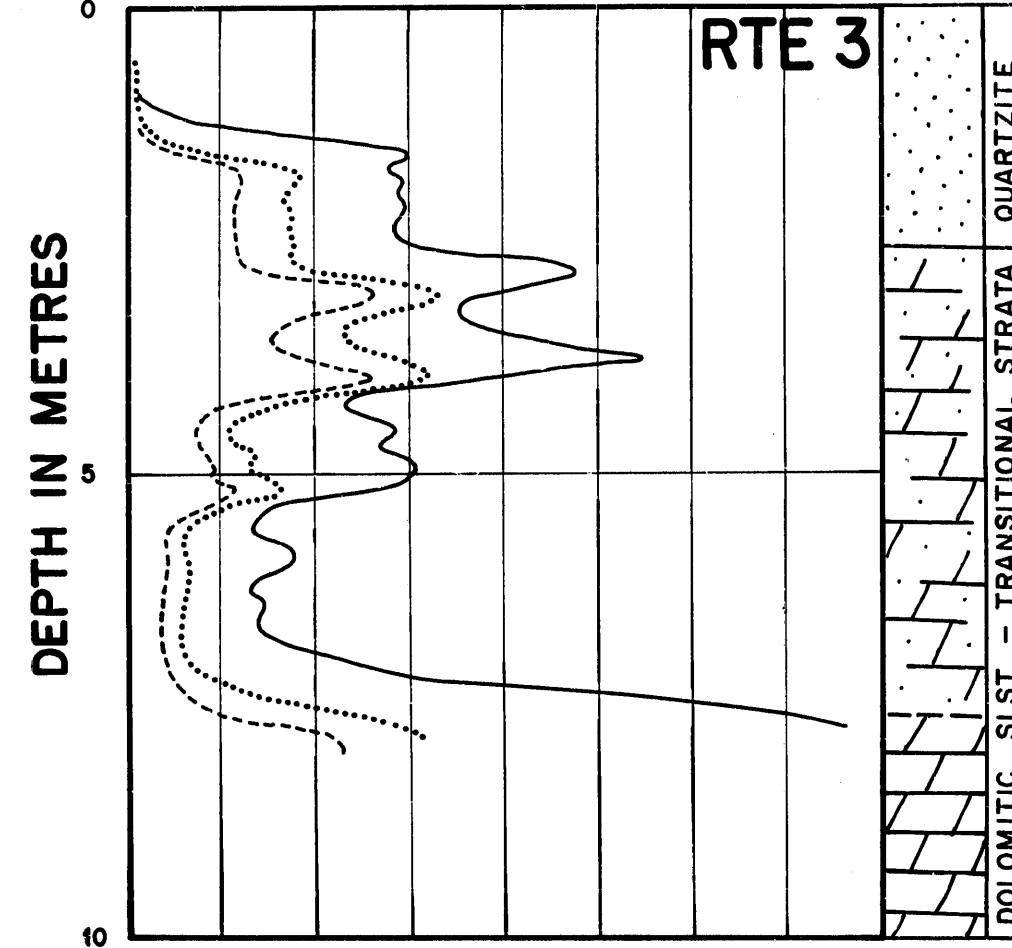


Reading for RTE 3 during grouting of adjacent hole RP75

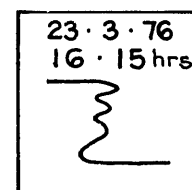


Reading for RTE 3 after completion of grouting RP75

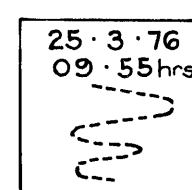
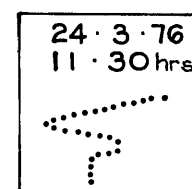
Results of grouting - RTE 3



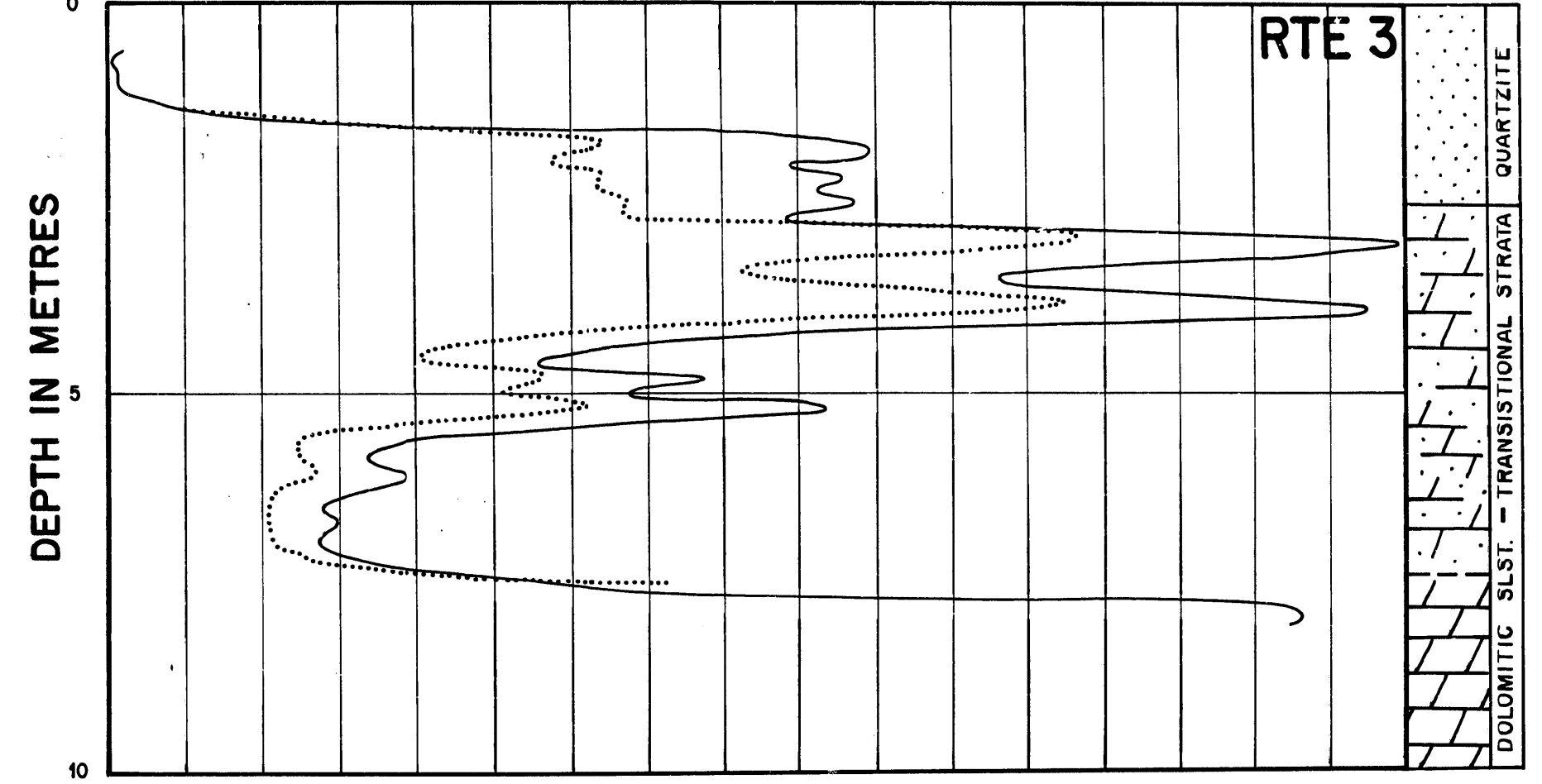
COUNTS PER SECOND
(Each division represents 12.5x100c.p.s.)



Shortly after grouting



Plotting of results at larger scale



COUNTS PER SECOND
(Each division represents 2.5x100c.p.s.)

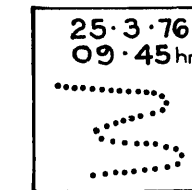
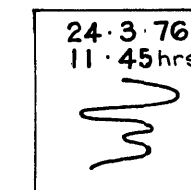


Fig. 32

DEPARTMENT OF MINES - SOUTH AUSTRALIA				
LITTLE PARA DAM				
RIGHT BANK GROUT CURTAIN ISOTOPIC GROUTING SCINTILLOMETER RECORDINGS				
ENGINEERING SERVICES	COMPILED J.C.BEAL	DRN L.C.	SCALE AS SHOWN	PLAN NUMBER
DIRECTOR OF MINES		CKD	DATE SEPTEMBER '76	76-757

- (1) The background readings in RTE 3 (Figure 32) show a marked difference at 3.5 m between the base of the quartzite and the top of the dolomitic siltstone; this difference most probably indicates the presence of clay derived from weathering of the dolomitic siltstone.
- (2) The effect of grouting the adjacent bore hole appears to reduce the intensity of the major peaks but increases the intensity of the in-between minor peaks. This increase may be explained by grouting up of small cavities and the decrease explained by flushing out of the thin reactive clay seams during the water testing process. Alternatively, grout deposited on the sides of the bore hole may have masked the natural background of radiation initially recorded as being associated with the clay seams.
- (3) Comparison between background values of RTE 3 and grouted values show a general reversal in the peak distribution. Higher peaks occur in the quartzite which has accepted more grout than the dolomitic siltstone which shows smaller peaks. This indicates the poor groutability of the weathered dolomitic siltstone.

The count per second increases markedly where grout has collected at the bottom of the borehole.

Readings taken two weeks after grouting were approximately one hundredth of the value of the early readings for sensitive measurements. It is preferable for recordings to be carried out within the first three or four days after grouting.

Background Readings on Block 'S'

Observation bores OB1, OB8 and AG2 were tested for background gamma emission values using a geiger probe in conjunction with a 'Nuclear Equipment Portable Scaler'.

Readings for the profile were taken every 250 millimetres.

All readings fell within the range of 0.7 - 3.7 counts per second and represent normal background values for the area. The higher readings, (greater than 3 c.p.s.) may indicate clay seams.

Readings from the Bromine 82 isotope should be 100-200 times greater than background even two or three days after grouting with the isotope. For this reason the background values are considered too low to affect bore hole gamma profiles during logging of the isotope grout and only the three observation bores mentioned above were logged for background profiles.

MAIN TEST

Outline of Test Programme on Block 'S'

The main test was carried out in three steps. Firstly, water pressure testing with dyed water in bore holes SP 116, SP 95 (1st stage only) and the central angled bore holes (AG 1, AG 2 and AG 3; Figure 33) secondly, grouting the 1st stages of SP 116 and SP 95 using isotopic grout and noting connections between the newly grouted holes and any of the observation bores or locating and drilling new observation bores. The final test checks the effectiveness of the grout curtain beneath grout caps block 'R' and 'S'. The summary of the grout and water pressure tests on holes SP 116 and SP 95 on Block S are shown on Figures 33 and 34.

Summary of Main Test Results:

1. During grouting of hole SP 116 grout loss increased from 0.1 bags dry cement (1st stage) to 16.4 bags (3rd stage; See Tables 10 and 11) Subsequent geiger probe measurements showed that these losses occurred at 2.0 - 3.0 m (Table 10) this is, at the base of the massive quartzite (Figure 35).

2. Grouting had blocked up some of the observation bores and they therefore could not be measured with the geiger probe over their full depth. However, geiger probe measurements in holes XS 7 and AG 2 (Figure 36) indicated interconnection with hole SP 116 between 3.0 m and 4.0 m with possible connections also at 5.5 metres and a connection between SP 116 and AG 3 at 8.5 metres.
3. This connection at 8.5 metres was also shown during the 1st stage water pressure testing of hole SP 116 (Figure 37). It is expected therefore that the flowing connections observed between SP 116 and the observation bores during all three grouting stages probably took place within the transitional strata at the same depths as the measured interconnections.
4. There was little grout loss during grouting of hole SP 95 (Table 10) but a connection to hole XS 4 during the second grout stage occurred at 1.5 and 3.0 metres (Figure 34) within and at the base of the massive quartzite.
5. Water pressure testing of hole SP 116 at 110 KPa showed reduced water losses: from 150 litres in 5 minutes (1st stage) to 42 litres in 5 minutes (3rd stage). This is the opposite to the grout losses which showed an increase in grout loss when the third stage of SP 116 was grouted three days later.
6. Water pressure testing of hole SP 95 remained very similar at 195 litres in 5 minutes (1st stage) to 100 litres in 3 minutes (3rd stage). This is the opposite to the grout losses which showed a marked decrease in grout loss when the third stage of SP 95 was grouted three days later.
7. The discrepancy between water loss values and grout loss values in SP 116 and SP 95 may be accounted for by the differences in the intervals of their 2nd and 3rd stages.

downstream

BLOCK 'T'

upstream

OB11

XS1 ⊗ X

AG1

XS5 ⊗ X

OB1

XS2 ⊗ X

AG2

XS6 ⊗ X

OB12

OB9

OB2

SPII6 ⊗ X

XS7 ⊗ X

OB6

OB13

OB10

OB3

XS3 ⊗ X

BLOCK 'S'

XS8 ⊗ X

OB7

OB4

XS4 ⊗ X

AG3

XS9 ⊗ X

OB8

OB14

10m

6m

SP95 ⊗ X

- Flowing connection (visual)
- Connected hole more than half filled with water.
- Connected hole less than half filled with water
- Trace water only
- Observation bore away from grout cap.
- Grout holes examined during testing.
- Angled observation borehole
- Proposed grout hole pattern.

⊗RSE2 ⊗REX3 ⊗AG4

⊗RTE1

⊗RP75 ⊗REX4

⊗RTE3

BLOCK 'R'

X

⊗RP74

0 1 2 Metres

Fig. 33

DEPARTMENT OF MINES - SOUTH AUSTRALIA

SCALE: AS SHOWN

COMPILED: B.J. BEAL

LITTLE PARA DAM

DATE: 22ND MARCH 1977

DRN: CKD

SUMMARY HOLES AG1, AG2, AG3, SP95 & SPII6
WATER CONNECTIONS DURING WATER
PRESSURE TESTING (PLAN)

PLAN NUMBER:

ENGINEERING SERVICES

S12684

downstream

BLOCK 'T'

upstream

● OB11

X
● AG1
XS1 ⊗ X X ⊗ XS5

● OB12

● OB9

● OB1 ● XS2 ⊗ X

X ⊗ XS6 ● OB5

● OB13

● OB10

● OB2 ● SPII6 ⊗

● AG2

X ⊗ XS7 ● OB6

● OB14

● OB3 ● XS3 ⊗ X

BLOCK 'S'

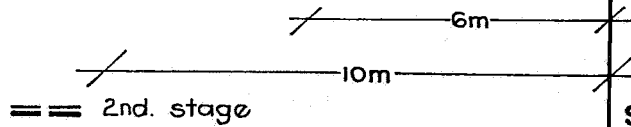
X ⊗ XS8 ● OB7

● OB4 ● XS4 ⊗ X

● AG3

X ⊗ XS9 ● OB8

SP95 ⊗



== 2nd. stage
=== 3rd. stage (SP95 NOT ISOTOPICALLY GROUTED)

↗ Flowing connection (visual)
→ Measured connection (geiger probe)

● Observation bore away from grout cap.

⊗ Grout holes examined during testing.

⊗ Angled observation borehole

X Proposed grout hole pattern.



⊗ RSE2 ⊗ REX3 ⊗ AG4

⊗ RTE1

⊗ RP75 ⊗ REX4

⊗ RTE3

BLOCK 'R'

X

⊗ RP74

Fig. 34

DEPARTMENT OF MINES - SOUTH AUSTRALIA

SCALE. AS SHOWN

COMPILED: B.J. BEAL

LITTLE PARA DAM

DATE: 22ND MARCH '77

DRN: L.C. CKD.

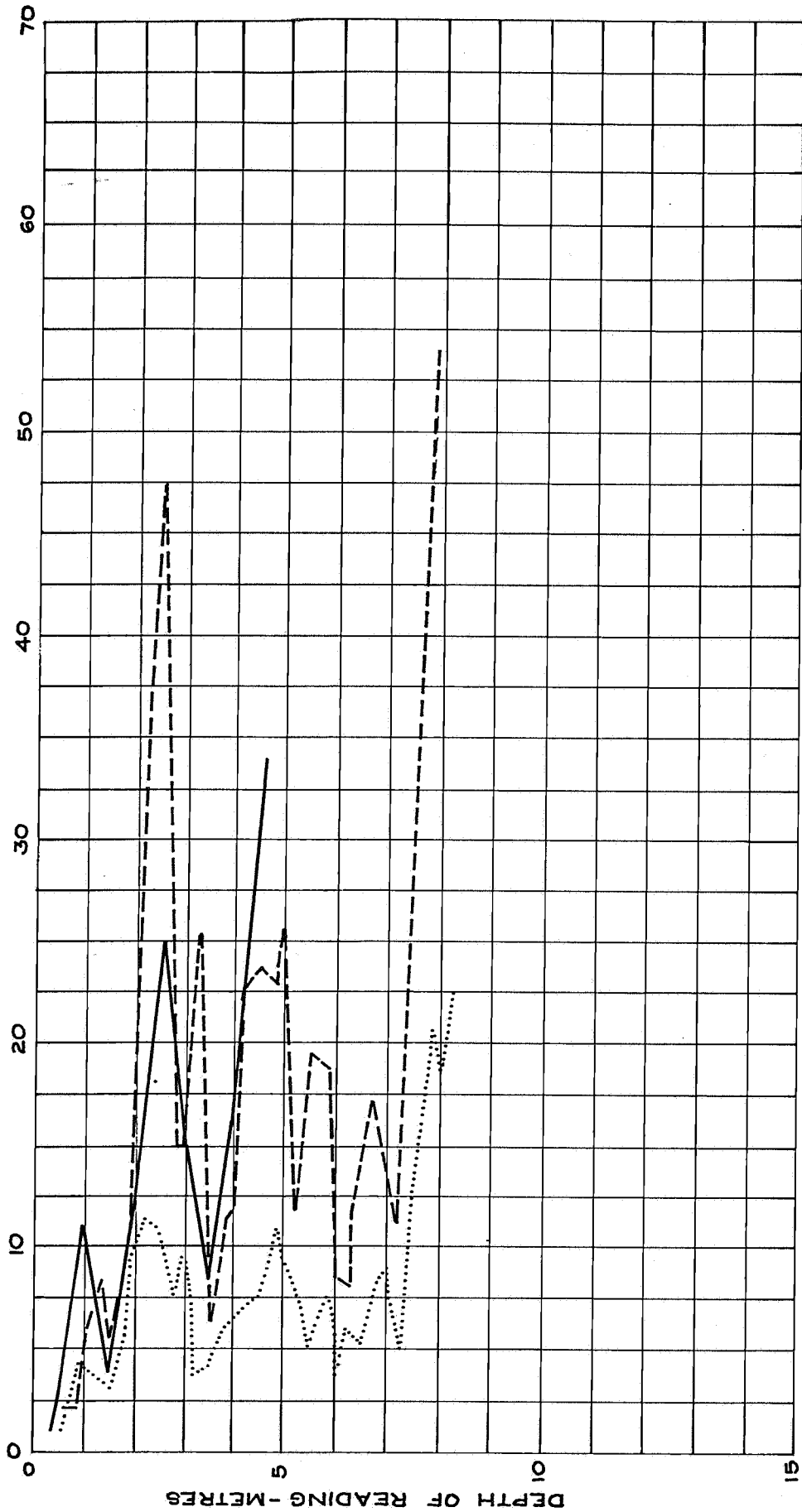
SUMMARY GROUT HOLES SP95 & SPII6
GROUT CONNECTIONS DURING ISOTOPIC
GROUTING (PLAN)

PLAN NUMBER:

ENGINEERING SERVICES

S12685

GEIGER PROBE - COUNTS/SECOND



— 1ST. stage (14-7-76)
 - - - 2ND. stage (27-7-76)
 3RD. stage (5-8-76)

Fig. 35

ENGINEERING SERVICES

DEPARTMENT OF MINES - SOUTH AUSTRALIA

SCALE - GRAPHICAL

COMPILED : J.C. BEAL

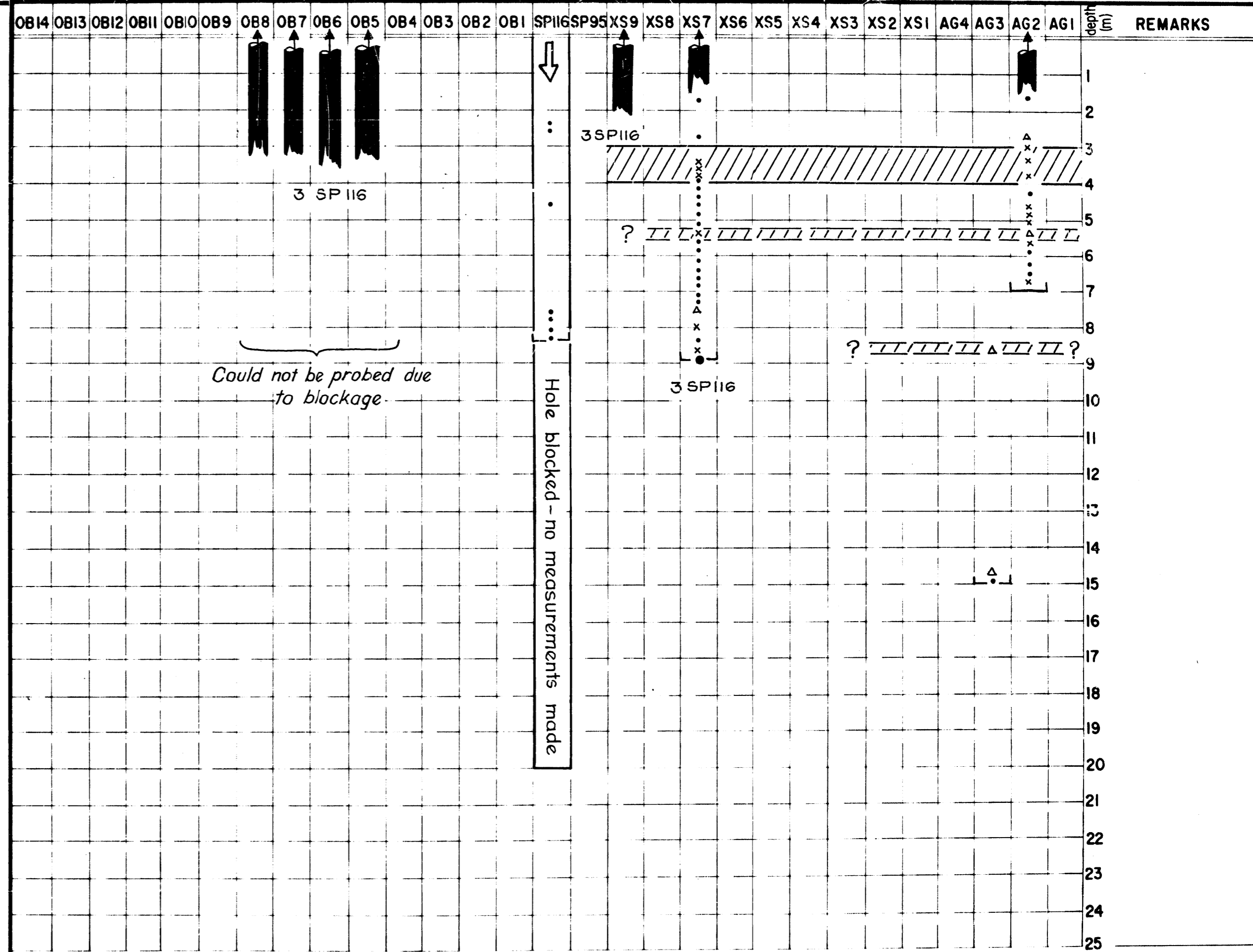
LITTLE PARA DAM
 GROUT CURTAIN INVESTIGATION
 GEIGER READINGS ON GROUT HOLE : SP116

DATE : 26TH APRIL '77

DRN : CKD.

PLAN NUMBER :

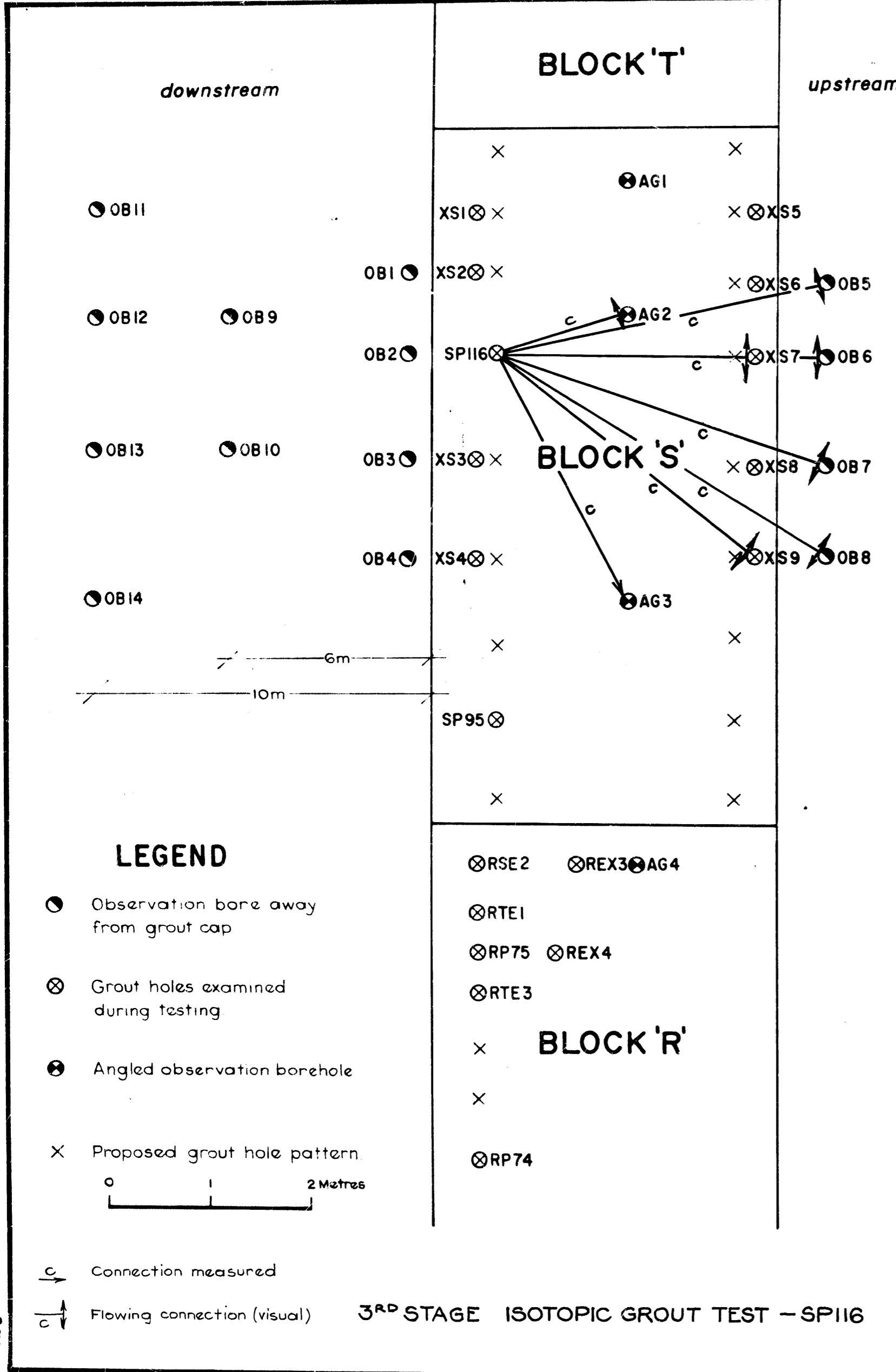
S12682



- nSPX Flowing grout interconnection during nth stage grouting of hole SPX
- nSPX Hole grouted during nth stage grouting of hole SPX
- Depth of hole tested
- NC. No connection
- NR. Not recorded; hole unuseable
- 10 - 30 cps
- x 30 - 50 cps
- Δ 50 - 70 cps
- > 70 cps

HOLE No : SP116	STAGE No : 3
Date Water Press test	30-7-76
Volume water loss	42 l/5min ; 15 l/5min
Date grouted	2-8-76
Volume grout loss	16.4 B (435 L dry cement)
Date isotope measured	3-8-76

DEPARTMENT OF MINES - SOUTH AUSTRALIA		SCALE
COMPILED		DATE
DRN	CKD	PLAN NUMBER
LITTLE PARA DAM BLOCK 'S' - GROUT SUMMARY SHEET ON 3rd. STAGE ISOTOPIC GROUT TEST - SP116		77-473



1/26

3RD STAGE ISOTOPIC GROUT TEST - SP116

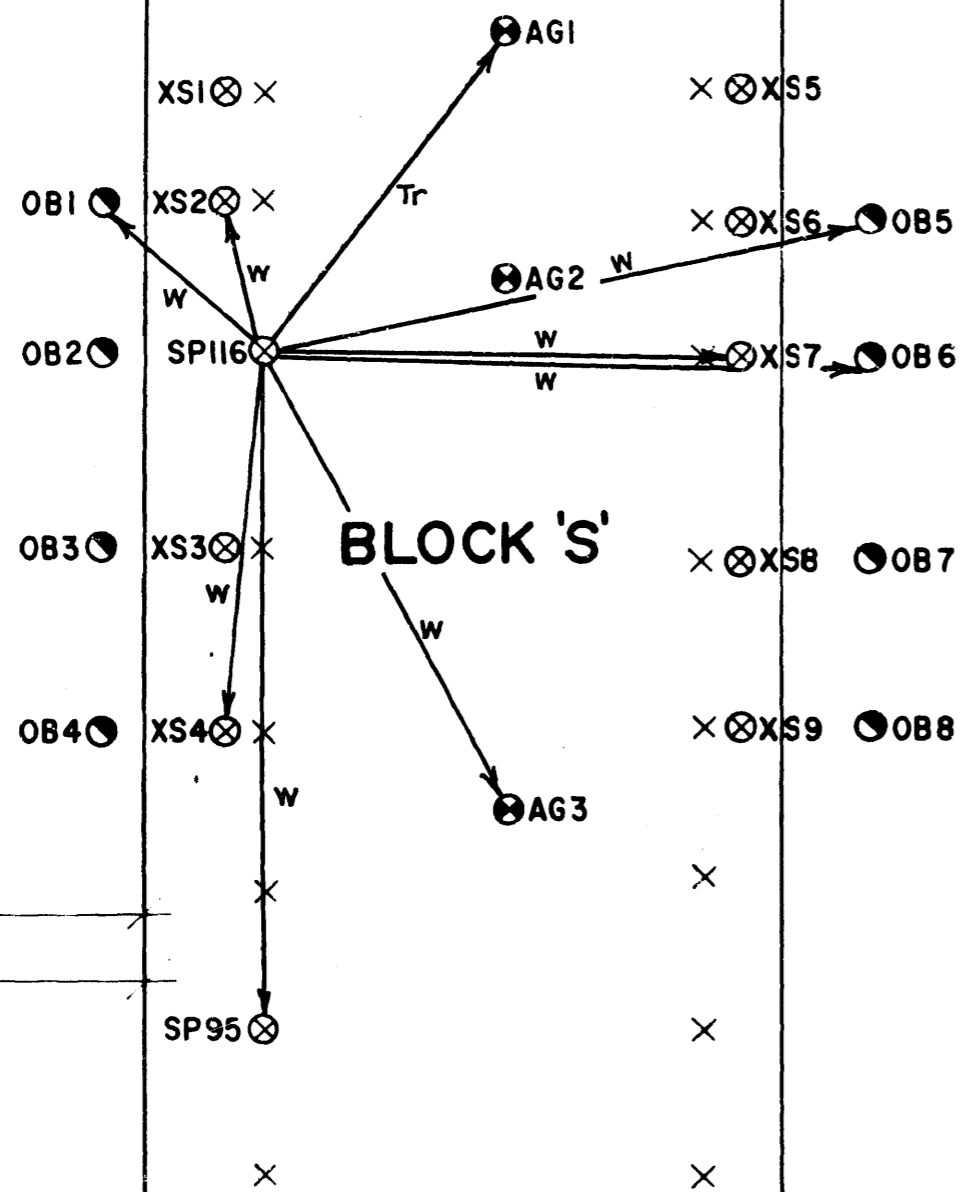
Fig. 36

downstream

BLOCK 'T'

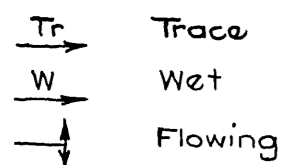
upstream

- OB11
- OB12
- OB13
- OB14
- OB9
- OB10



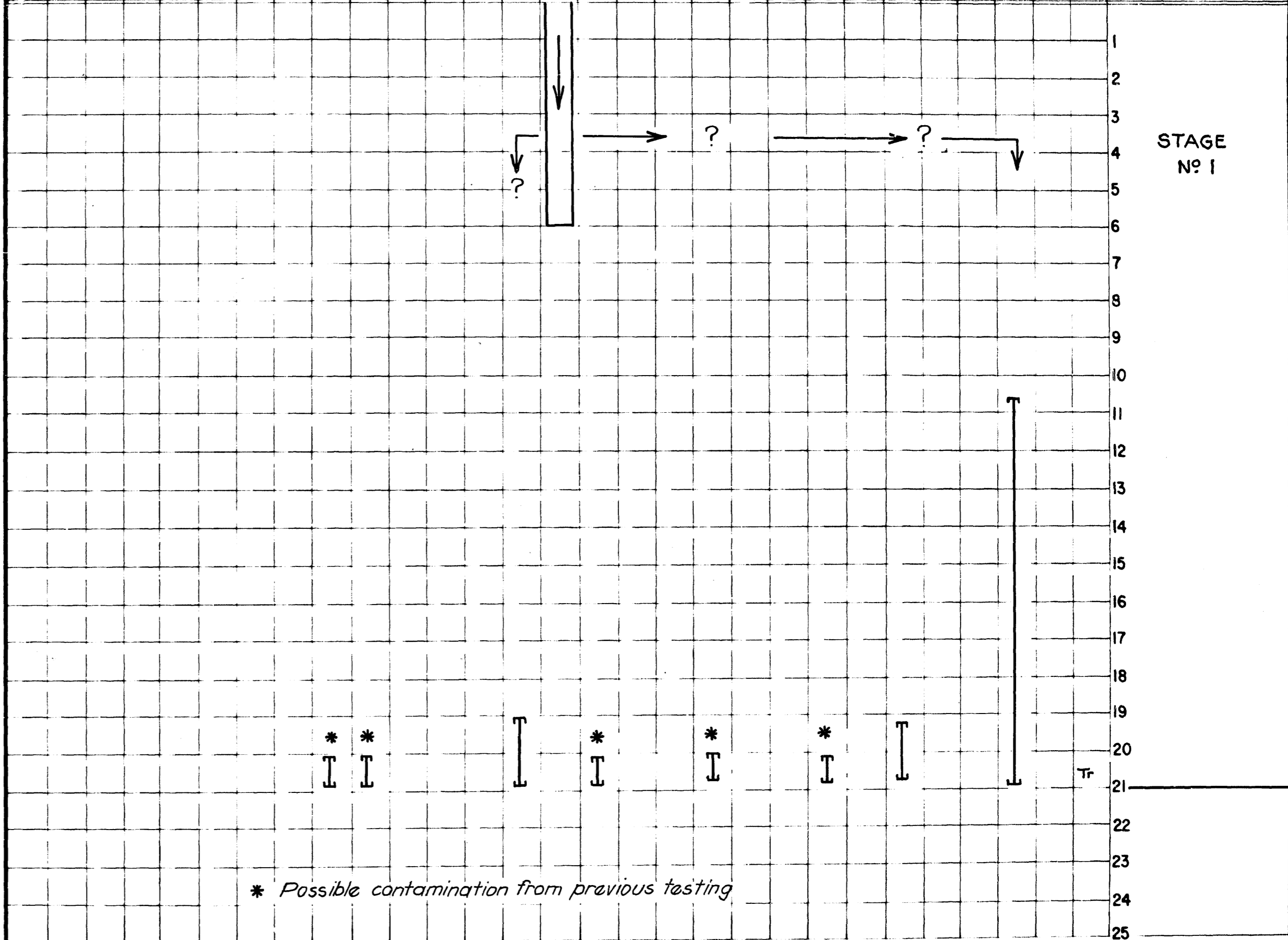
LEGEND

- Observation bore away from grout cap
- ⊗ Grout holes examined during testing
- ⊙ Angled observation borehole
- X Proposed grout hole pattern.



WATER PRESSURE TEST - SPI16

- ⊗ RSE2 ⊗ REX3 ⊙ AG4
- ⊗ RTE1
- ⊗ RP75 ⊗ REX4
- ⊗ RTE3
- X BLOCK 'R'
- X
- ⊗ RP74



STAGE No 1

- ┆_nSPX Flowing grout. Interconnection during nth stage grouting of hole SPX
- ┆_nSPX Hole grouted during nth stage grouting of hole SPX
- ┆ Depth of hole tested
- NC No connection
- NR Not recorded; hole unuseable
- 10 - 30 c.p.s. Tr Trace moisture or Rhodamine B stain
- x 30 - 50 c.p.s.
- Δ 50 - 70 c.p.s.
- > 70 c.p.s. I Tape wet

HOLE No : SP116	STAGE No : 1
Date Water Press test	13-7-76
Volume water loss	150L @ 300K Pa
Date grouted	
Volume grout loss	
Date isotope measured	

Fig. 37

DEPARTMENT OF MINES - SOUTH AUSTRALIA		SCALE CHART
LITTLE PARA DAM		DATE 23RD MARCH 1977
BLOCK 'S' - WATER TEST SUMMARY		PLAN NUMBER
SHEET OF SP 116 - STAGE 1		77-472

SP 95, 2nd stage was 7.0 - 10.0 m and SP 116, 7.0 m - 14.0 m. This suggests that the interval 10.0 m - 14.0 m (base of the transitional strata) is far more permeable than the strata between 14.0 m to 21.0 metres and that the high grout loss during 3rd stage grouting of a 3:1 grout mix in SP 116 did not move into the strata between 14.0 - 21.0 metres but into 1st stage levels. This is indicated during earlier grouting resulting in the uplift of grout caps Block M & N.

These uplifts occurred during the grouting of Blocks M and N when 366 bags of cement was used in the grouting hole MT 97 (3rd stage) and 365 bags in grouting hole NQ 114 (3rd stage) (Figures 42 & 43; Appendix 1). It is believed that the high third stage pressures caused dilation of the transitional strata bedding planes, in turn causing uplifts of the overburden and allowing the grout to travel a distance away from the hole being grouted.

Evidence of grout travel and dilation is that open grout holes drilled to 1st or 2nd stage in advance of the grouting programme (up to block P and lower part of Block Q), showed flowing grout during the grouting of NQ 114. Cessation of grouting and removal of the grout hose from the stand pipe nipple allowed grout to flow out of NQ 114.

The preferred movement of grout in the lower levels of the massive quartzite (transitional strata) has been further proved by the isotopic grout programme. This dilation of bedding planes is the direct consequence of downstage grouting from a stand pipe nipple when the full length of the grout hole is subjected to 3rd stage grouting pressures and overburden uplift results.

8. Plotting of water and grout interconnections on plan (Figures 33, 34, 36 and 37) show a strong preference for upstream movement.

The downstream observation holes (OB 1 - OB 4; OB 9 - OB 14) with only one exception (Figure 33 water from SP 116 to OB 1), did not record either the presence of grout or water. This is difficult to explain particularly as the strike of the strata is approximately across the alignment of the grout cap. Results may indicate a preferred upstream permeability of the strata or preferred direction for dilation of the bedding planes.

WATER PRESSURE TESTS ON THE COMPLETED GROUT CURTAIN

To check the effectiveness of the completed grout curtain three cored drill holes located in the centre of the grout curtain were water pressure tested up to a maximum pressure of 500 KPa.

The location and logs of the check holes (DH 23, DH 24 and DH 25) are shown in Figure 42 and Supplement 1, Appendix 1.

Testing was initially carried out at 2.0 m intervals using a double packer. Faulty operation of the lower part of the double packer while moving it from one interval and resetting on a higher interval led to very high lugeon losses (up to 70 lugeons). Interpretation of the data assuming the packer was acting as a single packer gave values of 2 to 7 lugeons. This was later verified by testing with a single packer.

Although it is possible to distinguish between a faulty packer and a highly permeable area (Pearson et. al. 1977) it was felt that sufficient knowledge of the likely permeability of the bedrock had been gained during the numerous water pressure tests on each grout hole during the grouting programme to allow the recognition of spuriously high results. The packer was taken out of the hole and the cause for its faulty operation identified.

The closure mechanism which operates at the commencement of a test was inadvertently opened while lifting the equipment to a higher position in the test hole. A single packer was used for the remaining tests by successively grouting lower parts

of the hole and moving the single packer up the hole to test the next interval (0.5 m to 1.5 metres), (Supplement 1, Appendix 1). Even with a single packer, increased permeabilities were recorded with application of higher pressures. A hysteresis loop recorded during the second stage of many of the tests (decreasing water pressure) also reflected the increase in permeability and was interpreted as dilation of the bedding planes rather than a leaking packer (Houlsby 1977; Pearson et. al. 1977).

Check hole DH 24, was located and angled to intersect the most likely area susceptible to potential leakage, that is, at approximately 10.0 m beneath grout cap block M where a shear zone intersects the weathered transitional strata immediately beneath the massive quartzite, (Unit 12) at approximately 10.0 metres. Losses of 11 to 20 lugeons were measured over the interval 9.50 m - 10.20 m. This is the same interval where the earlier self potential and point resistance work indicated a change in rock groutability. It is believed that the presence of the shear zone, within the zone of fluctuating groundwater table and the resultant localized weathering of the transitional strata can account for the relatively high lugeon losses over this interval.

Although low grout takes were recorded (Table 12) when test hole DH 24 was grouted it is thought that this is more indicative of the ungroutable nature of the weathered strata than of a water tight grout curtain.

Low lugeon values were recorded in the other two check holes DH 23 and DH 25 (3-5 lugeons and 0.5 lugeons respectively) and both recorded low grout takes when grouted (Table 12).

Results from water pressure testing of the check holes therefore show that lugeon losses of less than 7 are indicated over

most of the dam site except in the area where losses of up to 20 lugeons have been recorded over a short interval. The lower figure of 7 lugeons is regarded as satisfactory for this type of dam (Houlsby 1977 and Appendix 5).

DISCUSSION AND SUMMARY

Field research work run concurrently with an engineering project is of necessity compromised: the drilling equipment is requested elsewhere; the rockfill is to be placed earlier than calculated; field assistance is not always forthcoming, and other such problems beset the field research project.

Because the dam was mainly built by State Public Service day labour it was easier to occasionally modify the construction programme than it would have been had it been built entirely by contract work. This allowed the drilling, grouting and water pressure testing of the extra grout curtain holes required for the research programme.

Although it would have been easier to tackle the problem of establishing an investigation technique away from construction under laboratory type conditions, it is believed that tests carried out under real conditions are more valuable and from this point of view it is felt that efforts to develop a grout curtain testing technique have been worthwhile.

Use of isotopic grout has shown that the depth of grout takes and their location and thickness can be established, that the groutability of rock types may be assessed and that correlation of grout takes from hole to hole may in some cases be observed. The most favoured direction of grout movement during grouting can also be established. The Self Potential and Point Resistance methods are too inaccurate to use for locating the exact position of groutable bedrock.

Hole	Date	Stage Depth (m)	Volume of hole (litres)	Grout W/C	Grout Take		Injection Pressure KPa	Method
					Total incl. hole volume	Approx net (dry bags cement)		
DH 25 (Block D)	20.7.77	0 - 20.5 m	103	1:1	108	None	NIL	25 mm Tube (Tremmie)
DH 23 (Block S)	12.8.77	0 - 21.0 m	105	2:1	105	None	150	Nipple
DH 24 (Block M)	12.8.77	10.2 - 21.0 m	43	1:1	0*	None	150	Inf. Packer
	12.8.77	10.2 - 21.0 m	43	1:1	41	None	NIL	25 mm Tube
					*(Double Packer stuck) (@ 15 m)			
	19.8.77	8.4 - 10.2 m	9	2:1	15	0.09 B	250	Inf. Packer
	19.8.77	0.0 - 8.4 (Effectively 1.5 - 8.4)	34	2:1	32	None	150	Inf. Packer

TABLE 12 - SUMMARY OF GROUT CURTAIN CHECK HOLE GROUT TAKES

Although seams of completely weathered dolomitic siltstone occur at depths in nearly all the grout holes, high grout losses (other than where cavities within the weathered seams are believed to have been present) do not appear to be associated with these weathered seams but with the transitional strata found at the base of the massive quartzite.

The weathered dolomitic siltstone is not groutable and is not the site of water and grout losses observed during both the daily grouting and research programme. The water and grout losses are thought to have occurred along the open bedding planes and joints of the transitional strata. Grout penetration at shallow depths and at high pressures along these fractures resulted in small amounts of uplift of grout caps Block M and N (2-4 mm).

A study of the isotopic grout record shows that successful grouting of the flaggy quartzite has been achieved and that this may still have been possible even if a wider grout hole spacing had been used. Grouting of the weathered seams of dolomitic siltstone is considered impossible owing to its impermeable nature. However during the grouting programme it was noticed that water losses during cleaning of the hole prior to grouting were large compared to the low but not negligible grout takes. It is thought that the process of water testing may well have washed out the dispersive clay content of the weathered seam. This disparity between water loss and grout loss indicates that water losses cannot always be used to indicate similar losses when grouting.

The attempts to use Rhodamine B dye to indicate interconnections between grout holes during water pressure tests failed because the dye was adsorbed adjacent to the grout hole by the clay present in the seams of completely weathered dolomitic siltstone.

The wetting effect on canvas tape proved sufficiently sensitive to establish interconnections.

The three diamond drill holes within the grout curtain, when water pressure tested, gave lugeon values ranging from 1 in slightly weathered to fresh dolomitic siltstone to 7 in the transitional strata. Within completely weathered dolomitic siltstone lugeon losses of 11-20 were recorded over a 0.7 m interval. Values of 2 to 3 lugeons were recorded in the massive quartzite. For this type of rockfill dam lugeon values less than seven are considered acceptable.

The clay in the weathered seams is dispersive and thus potentially erodible but because the potential leakage paths are likely to be long (20.0 to 60.0 m) and the permeability of the completely weathered dolomitic siltstone moderate (1×10^{-4} cm/sec) erosion of the grout curtain as a whole by leaking water is not considered likely.

In retrospect a more comprehensive trial test should have been carried out on the grout curtain, so as to work out the practical problems and to give more time to planning the main test through all the three grout stages. On the other hand each research test disrupts the tight schedule of the construction programme, and some compromise is required.

V SURVEILLANCE PROGRAMME AND PROJECT EVALUATION

Table 13: Surveillance Check List.

Table 14: Water Well Recovery Test.

The Surveillance Programme

To monitor the post construction performance of the dam a surveillance programme (Table 13) began in December, 1977. The programme is designed to measure daily the rate of leakage through the dam and the change of groundwater levels in the right abutment during the first filling of the reservoir. After the dam is full the monitoring programme will continue with surveillance of reservoir leakage and groundwater levels and inspection of the dam structures at intervals commensurate with the early results and rate of the first reservoir drawdown.

Determining the origin and quantity of leakage or seepage through a rockfill dam is less precise than measuring the same through a concrete dam, since both the collecting elements inside the dam as well as the abutments and foundations are porous mediums into which the seepage entering through one point can be quickly distributed, therefore the discharge water issuing from the dam may have come from an extensive area. (Allende 1976, p. 182).

Downstream discharge at Little Para Dam prior to reservoir filling was due mainly to natural groundwater issuing from existing springs in the foundation of the dam. Post dam construction discharge originates from these springs plus the affect of filling the reservoir (leakage of water through the grout curtain and the upstream concrete deck) and also from rainfall. There has been no attempt to separately measure these three discharge sources.

However, discharge from behind the outlet duct on the left abutment is measured separately (ITEM 9, Table 13) and any increase in this measurement which is not accompanied by a

similar increase in the main discharge can only be interpreted as leakage through the left abutment with also possible leakage through the upstream concrete deck adjacent to or near the left abutment.

Total downstream discharge has reached a maximum of 14 litres/second, November, 1978 at reservoir level E.L. 141 m, the highest level reached during 1978. Seepage from the left abutment hill-side (Item 10, Table 13) adjacent to the Outlet Pipe remained low (6.35 litres per second) during reservoir filling. The main discharge, at the V-notch built into the Control House retaining wall, (Item 5 Table 13) remained fairly constant over the 6 months prior to filling at approximately 0.4 litres per second and gradually increased to 8.5 litres per second, in November, 1978 at reservoir level: E.L. 141 m. Discharge from behind the left hand side of the Outlet Duct (Item 9, Table 13) varied between 0.024 to 0.034 litres per second prior to the filling and gradually increased to 3.8 litres per second, in November 1978, at reservoir level E.L. 141 m.

Groundwater levels from two observation wells are being continuously monitored. These wells, MOB 1, and MOB 2, (Figure 38) are located adjacent to the downstream toe of the rockfill dam. MOB 2 (E.L. 146.6 m) remained dry during the early months of reservoir filling, water being recorded at E.L. 126 m August 8th, 1978 at reservoir E.L. 134 m. Prior to filling of the reservoir observation bore MOB 1, (E.L. 124.0 m), gave a static water level 11.45 metres below natural ground level (E.L. 112.55 m). The water level rose to E.L. 123 m during reservoir filling and remained stable at this level.

The depth and location of these two observation wells is such as to intercept and record changes in groundwater levels (Figure 38) resulting from the leakage of reservoir water through

TABLE 13

SURVEILLANCE CHECK LIST

TASK	ITEM NO.	FREQUENCY OF OBSERVATIONS DURING FILLING*	OFFICER RESPONSIBLE
Evidence of leakage: Downstream face of bank	1	twice daily	Resident Engineer to arrange for checks to be carried out in conjunction with Water Supply and Design Branches and Department of Mines and Energy (Refer to Site Geologist).
River bed up to 1/2 km downstream of bank	2	twice daily	
Left abutment up to 1/2 km downstream of bank	3	daily	
Right abutment up to 1/2 km downstream of bank	4	daily	
Head of water and hence discharge over the double V-notch in the downstream wall	5	twice daily	
Flow of water into duct drainage sump. Spillway drainage holes	6	twice weekly when water is within 5 m of spillway crest	
Depth of water passing through the downstream causeway	7	daily	
Depth of water over gauging weir downstream of the causeway	8	daily	
Leakage alongside of duct from left abutment	9	twice daily	
Leakage collected from seepage from broken rock area in left abutment immediately downstream of the duct	10	twice daily	
Evidence of slips in or above the reservoir area	11	fortnightly, after heavy rain, and after any rapid draw-down	

TABLE 13 continued
SURVEILLANCE CHECK LIST

TASK	ITEM NO.	FREQUENCY OF OBSERVATIONS DURING FILLING*	OFFICER RESPONSIBLE
Internal face of the walls of the tower-check signs of seepage, special emphasis to be devoted to concrete surrounding the bellmouths and the dayplane joints	12	daily	Visits by appointed officers to be arranged on a roster basis with a minimum weekly visit by an appointed geologist.
Internal face of the duct	13	monthly	
Face slabs on the bank-check especially for spalling along the vertical joints or at the grout cap/face slab interface	14	weekly	
Spillway concrete, rock below the ski-jump after spillage	15	after spillage	
Area adjacent to river outlets after operation	16	after operation	
Spillway floor, walls, apron and adjacent cliff	17	after spillway operates	
Instrumentation monitoring	18	to follow existing procedures	

* To be revised after filling.

TABLE 14
DEPARTMENT OF MINES AND ENERGY
SOUTH AUSTRALIA

DRILLING AND MECHANICAL BRANCH

Well No..MOB.1.....
PRODUCTION/OBSERVATION

WATER WELL RECOVERY TEST

PROJECT/OWNER: Engineering & Water Supply Department

Little Para Dam - Surveillance Programme

AVERAGE PUMPING RATE 1.64.... ~~kl/hr~~ m³/day

TEST TYPE: Pump/Air-Lift/
Bailer

PUMP STOPPED AT 11.00 a.m. ON 31/.3/.78

STAGE NO.: -

RECOVERY MEASUREMENTS

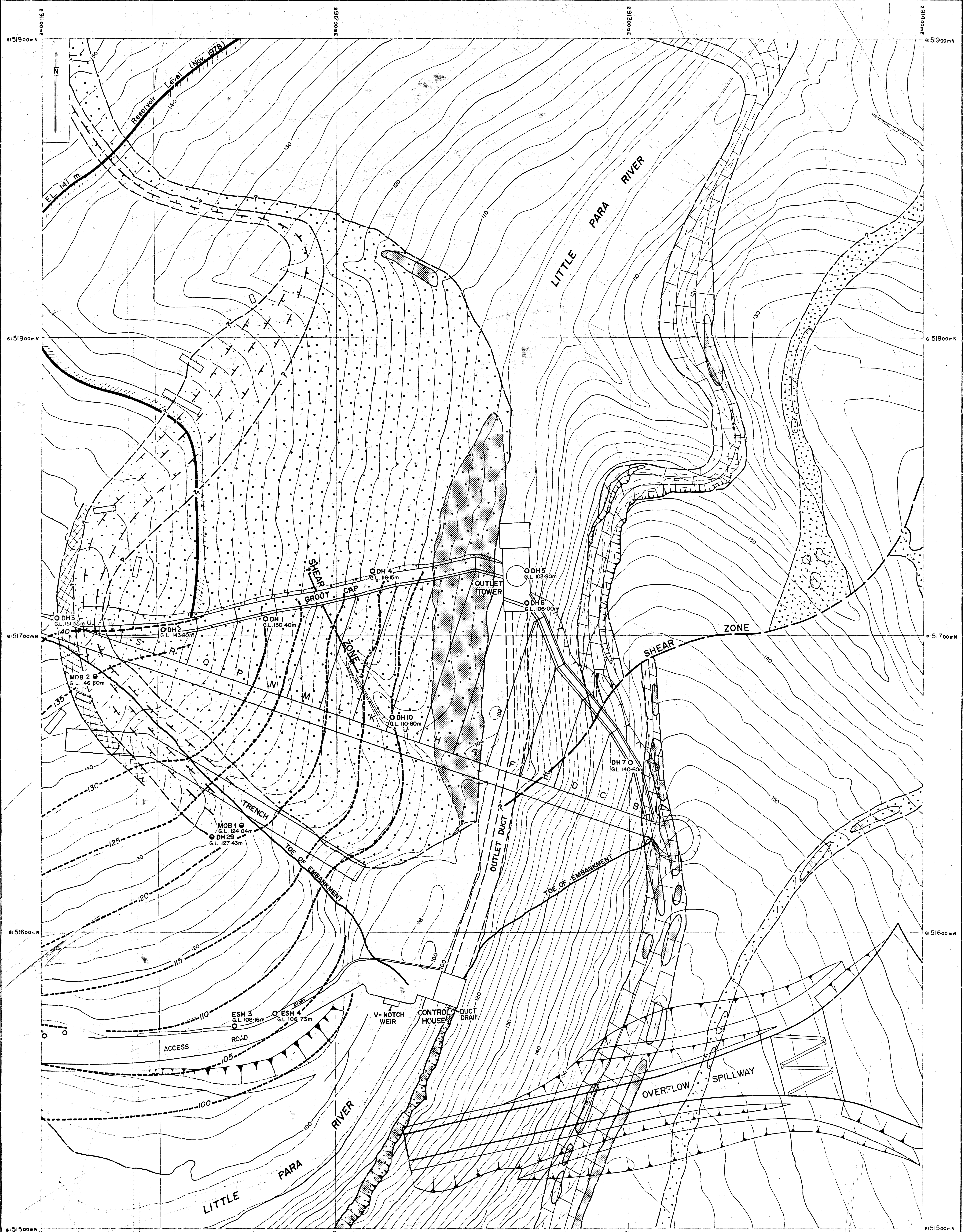
STOPPED AT 12.32 p.m. ON 31/.3/.78..

Note: Use black ball pen and fill in form completely.

Minutes after pump		t t ₁	RESIDUAL DRAWDOWN m	Minutes after pump		t t ₁	RESIDUAL DRAWDOWN
Start (t)	Stop (t)			Start (t)	Stop (t)		
17½	0		1.22 m				
18½	1	18.5	1.17				
19½	2	9.75	1.13				
21½	4	5.37	1.11				
23½	6	3.91	1.055				
25½	8	3.19	1.01				
27½	10	2.75	.965				
32½	15	2.17	.845				
37½	20	1.88	.755				
42½	25	1.7	.675				
47½	30	1.58	.60				
57½	40	1.44	.485				
70	52½	1.33	.40				
77½	60	1.29	.34				
92½	75	1.23	.255				
				<u>Notes</u>			
				Conductivity 1200 umhos at 19°C			
				S.W.L.: 31/3/78 12.45 metres from top of stand pipe.			

Performed by B. Eberhard Analysed by J.C. Beal.....

Sheet ...1. of ...1...



LEGEND

- Quartzite - with outcrops
- Transitional strata
- Dolomitic siltstone
- Dolomitic siltstone (slaty) - with outcrops
- Dolomitic siltstone - completely weathered
- Ground contours - 2.0 metre interval
- Reservoir level EL. 141 m. Nov. 1978
- Calculated groundwater levels Nov. 1978
- ESH 2 Earth strap hole
- MOB 2 Groundwater level observation well
- DH 29 Diamond drill hole

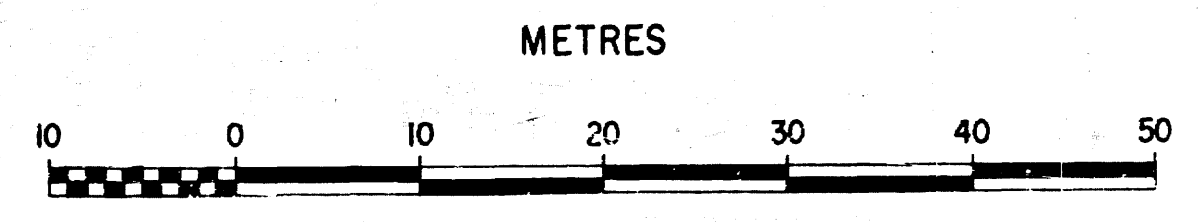


FIG. 38

DEPARTMENT OF MINES AND ENERGY - SOUTH AUSTRALIA

LITTLE PARA DAM
SURVEILLANCE PROGRAMME
 OBSERVATION WELLS & GROUNDWATER CONTOURS
 (RIGHT ABUTMENT)

COMPILED J. BEAL | DRAWN W. W. | SCALE | PLAN NUMBER 79-50
 DIRECTOR GENERAL | DATE JAN. 1979

the grout curtain into the right abutment. Any increase in rate of rise of water level in the observation bore greater than an increase in rise of reservoir will warrant very close inspection even if the bore water level may be metres below reservoir level (Penman, 1977).

A third observation bore DH 29 drilled adjacent to MOB 1 is not fitted with a continuous water level recorder but is read manually. This bore serves to check the readings in MOB 1. To date recordings for the two bores have been in agreement with one another.

Results from the Surveillance programme conclude that the change in downstream discharge and the groundwater levels reflects the saturation of bedrock due to filling the reservoir and indicates some leakage through the dam. This leakage is to be expected and is not considered great enough to endanger dam safety (see tables in Appendix 5).

Inspection of the two reverse filter trenches excavated into the completely weathered seams of dolomitic siltstone downstream of the parapet wall, has shown that the trench has remained dry and that there has been no leakage through the grout curtain at the top of the right abutment or beneath the 2.5 - 3.5 metre deep concrete footing of the parapet wall.

Although short seepage paths through the grout curtain may occur via the weathered seams of dolomitic siltstone it is very unlikely that a long seepage path from the grout curtain to downstream of the dam is possible.

Using observation bore MOB 1 approximate values of 0.1 to 0.62 cubic m/day/m have been obtained for the transmissivity of groundwater in moderately weathered dolomitic siltstone (Table 14).

This is a very low value and providing that it is typical of the foundation strata of the dam then physical erosion of weathered strata will not occur. The rockfill dam is designed to cope with leakage and apart from possible stability problems loss of some water from the reservoir through the embankment and beneath the dam is not critical.

The groundwater contours (Figure 38) indicate that groundwater levels approximate to surface contours and do not indicate water flow away from the dam. Springs are evident in a few locations where groundwater levels intersect topographic contours. For example the spring from earth-strap hole ESH 2, Figure 38 and from the quartzite at E.L. 110 and E.L. 100 respectively.

As well as measurement of discharge and groundwater levels and the routine inspection of the dam and spillway, hillside survey pegs upstream of the dam are being monitored fortnightly or immediately following heavy rain or rapid reservoir drawdown. This survey is to assess the possibility of hillside slip into the reservoir. The area is one of shallow calcimorphic clay soils overlying a weathered dolomitic siltstone bedrock. It covers an area of approximately 25,000 squ. metres and has a very approximate maximum soil volume of 45,000 cubic metres. To date there has been no record of hillslope movement except for a slight increase in elevation (1-3 mm) attributed to ground swelling as the rising reservoir level saturates the ground adjacent to the survey pegs.

PROJECT EVALUATION

Geological Investigation

There are many guidelines for investigating a dam site and reservoir (Burgess 1975, Dearman, et al., 1974, Hofman, 1973, Knill, 1971, Roberts et al., 1975, Stapledon, 1964 and Wahlstrom, 1974) but they can at the best be only guidelines as each site is

unique with its own geological and construction problems.

The Little Para Dam project being first discussed as early as 1959 (see S. Aust. Dept. Mines unpublished reports) has of necessity had an unco-ordinated early investigation period, not regulated by any stricter guidelines than those of finance, and water requirements to meet estimated population growth. Not until 1973 when building of the dam was assured could the results of previous investigations be incorporated into the final investigation and the programme for the project planned.

This discontinuous appraisal of the project had the advantage of involving several geologists and engineers and that by the time the construction period commenced the area was well understood and communication between geologists, design and construction engineer well established.

The Construction Period

It seems to be a fact of life that on a construction site engineers request a report on a specific aspect before the geologist has had time to complete his investigations. A flexible approach to reporting was therefore essential, as was early organization of the project in terms of communication and co-operation between the geologist and engineer (see Stapledon 1976). Engineers were asked as early as possible in the project what particular service they required from the geologist. Equally importantly the geologist advised the engineer of any particular aspect of the project he thought warranted early investigation.

As well as reports covering specific investigations several progress reports were compiled and submitted to a working review committee. The latter were sometimes out of date by the time of completion but served to record work done rather than solely to advise.

Detailed surveyed plans and colour photographs were used in all the reports although the plans and photographs sometimes had to be added to the text at a later date.

Important day to day communication between geologist, construction engineer, design engineer, site surveyor and site workmen was all verbal with follow up memoranda, letters or reports when required.

Presentation of a report to a project working committee involved the discussion of geological facts, assumptions made and the interpretation in respect to the site work currently being investigated. Assumptions made in interpretation of site data were pointed out to the committee particularly if an early decision was required based on minimum geological information.

Mapping

Aerial photographs at 1:1 000 scale were ideal for early geological investigations. For detailed work during the construction stage plans at 1:500 and 1:250 scales were the most useful. The site surveyor was greatly assisted if the need for small scale detailed plans could be anticipated. Often an immediate need could not be anticipated and tape and compass diagrams were used until the surveyor had time to complete the required plan.

Where the design engineers requested immediate information from the results of a bulldozer trench, backhoe pit or drill holes, mapping or logging was carried out sufficiently well to give them an immediate verbal report followed by a written report with accompanying surveyed plans.

Records

A complete photographic record including coloured photographs and transparencies was kept during the construction of the dam and its appurtenant structures.

Photograph negatives and copies of all reports have been stored in the records section of the South Australian Department of Mines and Energy.

W.R.P. BOUCAUT.

John C. Beal

J.C. BEAL.

REFERENCES

SOUTH AUSTRALIAN DEPARTMENT OF MINES AND ENERGY

UNPUBLISHED REPORTS

- Beal, J.C. 1973. Some engineering geology aspects of the proposed Little Para Dam Site. S. Aust. Dept. Mines report 73/212.
- Beal, J.C. 1973. Little Para Dam - proposed spillway alignment S. Aust. Dept. Mines report 73/219.
- Beal, J.C. 1973. Little Para Dam, outlet duct alignment, report on geological investigations. S. Aust. Dept. Mines, report 73/274.
- Beal, J.C. 1974. Little Para Dam - detailed geological mapping of the grout cap alignment, S. Aust. Dept. Mines, report 73/310.
- Beal, J.C. 1974. Little Para Dam outlet tower and control house, report on foundation excavations S. Aust. Dept. Mines, report 74/24.
- Beal, J.C. 1974. Little Para Dam water treatment works, quarry site, and main separation pipe, S. Aust. Dept. Mines report 74/133.
- Beal, J.C. 1976. Little Para Dam site report on materials testing, S. Aust. Dept. Mines report 76/28.
- Beal, J.C. 1977. Little Para Dam slope stability analysis on quarry and water treatment works, S. Aust. Dept. Mines report 77/93.
- Boucaut, W.R.P., Beal, J.C., 1979. The engineering geology of the Little Para Dam site. S. Aust. Dept. Mines report 79/2.
- Dixon, H. 1973. Little Para Dam geological investigation progress report No. 4, S. Aust. Dept. Mines report 73/232.

- Flint, D.J. 1973. Little Para Dam - reservoir area geological investigations S. Aust. Dept. Mines report 73/183.
- Gerdes, R.A. 1973. Report on seismic refraction survey at Little Para Dam site. S. Aust. Dept. Mines report 73/174.
- Johnson, P. 1977. Little Para Dam, logs of exploratory trenches, S. Aust. Dept. Mines report 77/26.
- Johnson, W. 1959. Preliminary geological investigation of two alternative dam sites on the Little Para River. S. Aust. Dept. Mines report 49/144.
- Johnson, W. 1960. Geological investigations Little Para river dam site, S. Aust. Dept. Mines report 51/46.
- Kingstone, D., Shepherd, R.G. 1973. Proposed Little Dam - effect on intake to aquifers of northern Adelaide plains, S. Aust. Dept. Mines report 73/246.
- McInerney, P., Stadter, M. 1976. Little Para Dam. Further investigations of the foundation conditions for the water treatment works, report 77/127.
- Nelson, R., 1975. Seismic refraction survey over the spillway recharge area at Little Para Dam, S. Aust., Dept. Mines report 75/61.
- Steel, R.D. 1964. Preliminary report on geological investigation for concrete arch dam on Little Para River, alternative sites 3 & 4, S. Aust., Dept. Mines report 58/14.

REFERENCES

- Allende, J.L., 1976. Leakage investigation and drainage of dams and their foundations. General report by commission international des grands barrages. Douzieme congres des grands barrages Mexico, 1976.
- Atkinsen, T.C., Smith, D.I., Lavis, J.J., and Whitaker, R.J., 1973. Experiments in tracing underground waters in limestone. J. Hydrol., 19:323-349.
- Attewell, P.B., Farmer, I.W., 1976. Principles Eng. geol. J. Wiley & Sons Inc. N.Y.
- Bowen, R., 1975. Grouting in Engineering Practise. Applied Science Publisher Ltd., Ripple Road, Barking, Essex, England.
- Burgess, P.J., 1975. Site investigations in rock. Subject in post graduate course, St. Lucia University, Brisbane (unpublished).
- Cambefort, H., 1977. The principles and applications of grouting Q. J. Eng. geol. 10:57-95.
- Dearman, W.R., 1976. Weathering classification in the characterisation of rock: a revision. Bull. Int. Ass. Eng. geol.: 13:123-127.
- Dearman, W.R., Fookes, P.G., 1974. Engineering geological mapping. Q. J. Eng. geol. 7: No. 3.
- Fookes, P.G., Sweeney, M., 1976. Stabilization and control of local rock falls and degrading rock slopes. Q. J. Eng. geol. 9:37-55.
- Hazeldene, R.K., 1975. The rock slope stability of the River-view and Montacute aggregate quarries, Mt. Lofty Ranges. S. Aust. Inst. Tec. Diploma thesis (unpublished).

- Hoek, E., Bray, W.J., 1974. Rock slope engineering Inst. Min. Metall.
- Hofmann, G.W., 1973. Engineering geological techniques used in dam site investigations by the geol. survey of Queensland. Geol. Surv. Qd. report 76.
- Houlsby, A.C., 1977. Foundation Grouting for Dams. ANCOLD Bull., 47:5-23.
- Knill, J.L., 1971. Assessment of reservoir feasibility. Q. J. eng. Geol. 4,355.
- Lancaster, Jones, 1975. The lugeon water test, Qu. J. eng. Geol. 8.151.
- Lockwood, P., 1971. Water tracing with rhodamine B extra at Bungonia. J. Sydney Speleol. Soc. 15 (1) : 11.
- Londe, P., 1977. Comment on paper by Stapledon D.H. Bull. IAEG 14 p. 249. Bull. Int. Ass. eng. geol. 15: p. 22.
- Miller, D.J., 1973. Little Para Reservoir ecological survey Water and Sewage Treatment Branch, Engineering and Water Supply Dept., Adelaide (unpublished).
- Pearson, R., Money, M.S., 1977. Improvements in the lugeon or packer permeability test. Q. J. eng. Geol. 100:221-239.
- Penman, A.D.M., 1977. The failure of Teton Dam. Ground Engineering 19-27 Sept. 1977.
- Perry, E.B., 1973. Piping in earth dams constructed of dispersive clay; Literature review and design of laboratory tests, soils and pavements laboratory. U.S. Army Eng. Waterways exp. Stn. Tec. report S-75-15.

- Roberts, G.T., Cole, B.A., and Barnett, R.H.W., 1975.
Engineering geology of Scotts Peak dam and adjacent
reservoir watertightness. Aust. Geomechanics J., 1975.
39-47.
- Sherard, J.L., Dunnigan, P.L., Decker, R.S., 1976. Identification
and nature of dispersive soils. J. geotechnical eng.
Div. Am. Soc. Civ. Eng. April, 287-301.
- Smart, P.L., and Smith, D.I., 1976. Water tracing in tropical
regions, the use of fluorometric techniques in Jamaica.
J. Hydrol. 30:179-195.
- Stapledon, D.H., 1976. Geological hazards and water storage.
Paper presented to 25th Int. Geol. Congress, Sydney.
Bull. Int. Ass. eng. geol.: 14:249-262.
- Stapledon, D.H., 1964. Geological feasibility studies for a large
dam. Paper presented to Geol. Soc. Aust., Adelaide,
South Australia, 17th July, 1964. (unpublished).
- Stapledon, D.H., and Casinader, R.J., 1977. "Dispersive soils
at Sugarloaf dam site, near Melbourne, Australia,"
Dispersive clays, related piping, and erosion in
geotechnical projects, ASTM STP 623, J.L. Sherard and
R.S. Decker, Eds., American Society for Testing and
Materials, 1977, pp. 432-466.
- Trudinger, J.P., 1973. Engineering geology of the Kangaroo Creek
dam Bull. geol. Surv. S. Aust. 44.
- Wahlstrom, E.E., 1974. Dams, Dam Foundations and Reservoir Sites.
Developments in Geotechnical Eng. 6, Elsevier Scientific
Publishing Co.

APPENDIX 1

REPORT ON
GROUTING AND WATER PRESSURE
TESTING AT LITTLE PARA DAM

by

R. STOCKER
(ENGINEER, ENGINEERING AND WATER
SUPPLY DEPARTMENT) PUBLIC SERVICE OF
SOUTH AUSTRALIA

and

J.C. BEAL
(GEOLOGIST, DEPT. OF MINES AND ENERGY)
PUBLIC SERVICE OF SOUTH AUSTRALIA

CONTENTS

ABSTRACT

GROUTING PROCEDURES

Introduction

Purpose

Table 15 - Water testing Report form

Table 16 - Grouting Report form

Table 17 - Calculation Summary Sheet

SUPPLEMENT 1. Water Pressure Test Results on
Check Hole DH 24.

Figure 39 Down stage Grouting Without
Packer.

Figure 40 Drilling Sequence for Downstage
Grouting.

Figure 41 Right Abutment Drilling and
Grouting Procedures.

Figure 42 Grout take Summary - Geological
Cross Section.

Figure 43 Grout take Summary - Plan.

Figure 44 Water Pressure tests - Lugeon
Values on hole DH 24.

Figure 45 Lugeon test Calculation Sheet.

GROUTING AND WATER PRESSURE TESTING
AT LITTLE PARA DAM

ABSTRACT

Downstage non-packer grouting using maximum pressure of 500 KPa was carried out in three 7.0 m stages. The average grout take was 2.0 kg/m (0.5 m bags dry cement per stage).

Water pressure testing was carried out over 10 mins. (5 mins. at 110 KPa; 5 mins. at stage grout pressure).

An initial grout mix of 5:1 was used unless high water losses indicated use of a higher mix (1:1 maximum). A start mix of 3:1 was used in areas of potential grout cap uplift.

Refusal of a grout hole was taken as a maximum of 10 litres of grout (7 bags 294 kg at 1:1 mix) in 15 minutes.

Water pressure testing of three grout curtain check holes gave lugeon values of 3-1. These figures are acceptable.

GROUTING PROCEDURES

INTRODUCTION

Grouting can be defined as the injection of materials (in this case, cement slurry) into foundation rock so as to reduce permeability and increase its strength.

The grouting at Little Para Dam was of two types; blanket grouting confined to the Tower Base region and curtain grouting along the length of the grout cap. (Figure 39).

PURPOSE

Blanket Grouting

The tower base slab was post tensioned to the rock foundation by means of high tensile Macalloy bars. To increase the strength of the foundation rock subject to the post tensioning and weight of the Outlet Tower, blanket grouting was used to reinforce the rock to a depth of 11.5 m.

Curtain Grouting

The grout cap is a concrete slab designed to seal the joint where the upstream face of the Dam meets the rock. It was not embedded but laid directly onto a foundation cleaned down to tight, fresh bedrock or treated with dental concrete where required.

Two rows of holes were drilled through the grout cap, twenty metres into the rock, for the purpose of injecting a cement slurry under high pressure to form an impermeable grout curtain right across the valley. The curtain grouting aimed to extend the impermeable grout cap a distance of approximately twenty metres into the foundation. However, the "effective depth" of the grout curtain was less than 20 metres. On the right abutment, the effective depth of the curtain was 21 metres. On the left abutment, the effective depth of the curtain was $21 \text{ m} \times \cos 30^\circ$ (approx. average slope of the grout cap) ie. 18 m. On the left abutment the majority of the holes were 30° to the vertical and on a bearing of 18° (ie. at right angles to the dam axis) which resulted in a minimum effective depth of approximately 7 metres. Table 15 and Table 16 shows the method of recording data for foundation water testing and foundation grouting respectively. The data was later summarised for each grout hole (Table 17).

In block B of the left abutment, an additional line of holes were grouted which formed a third curtain. These holes were drilled vertically resulting in an effective curtain depth of 16 m.

TABLE 15

DEPARTMENT OF MINES - SOUTH AUSTRALIA
FOUNDATION WATER TESTING REPORT - LITTLE PARA DAM

S.R.E.	
A.R.E.	
S.E.A.	J.M.

Day TUESDAY
Date 12/10/76
Shift DAY

FOREMAN M. HALLIDAY

HOLE NO.	TIME			STAGE		WATER (LITRES)			NET TAKE L	(kPa) PRESSURE AS INTAKE	REMARKS Rate of Take, Leaks, etc.	
	FROM	TO	PERIOD (MIN.)	NO.	FROM (METRES)	TO (METRES)	START	FINISH				INJECTED
CT150	8.02 am	8.07	5	3	15	21	60	76	16	24	110kPa 500kPa	
	8.07	8.12	5				76	84	8			
BS151	8.17	8.22	5	2	9	15	84	95	11	24	110 250	
	8.22	8.27	5				95	108	13			
BS152	8.35	8.40	5	2	9	15	108	150	42	98	110 250	
	8.40	8.45	5				150	206	56			
AT114	8.57	9.02	5	3	15	21	6	56	50	117	110 500	
	9.02	9.07	5				56	123	67			
BS139	9.10	9.13	3	2	9	15	65	165	100		110	Taking quickly - no sign of stopping

TABLE 13 Foundation Water Testing Report

TABLE 16

DEPARTMENT OF MINES - SOUTH AUSTRALIA

FOUNDATION GROUTING REPORT - LITTLE PARA DAM

S.R.E.	
A.R.E.	
S.E.A.	J.M.

FOREMAN M. HALLIDAY

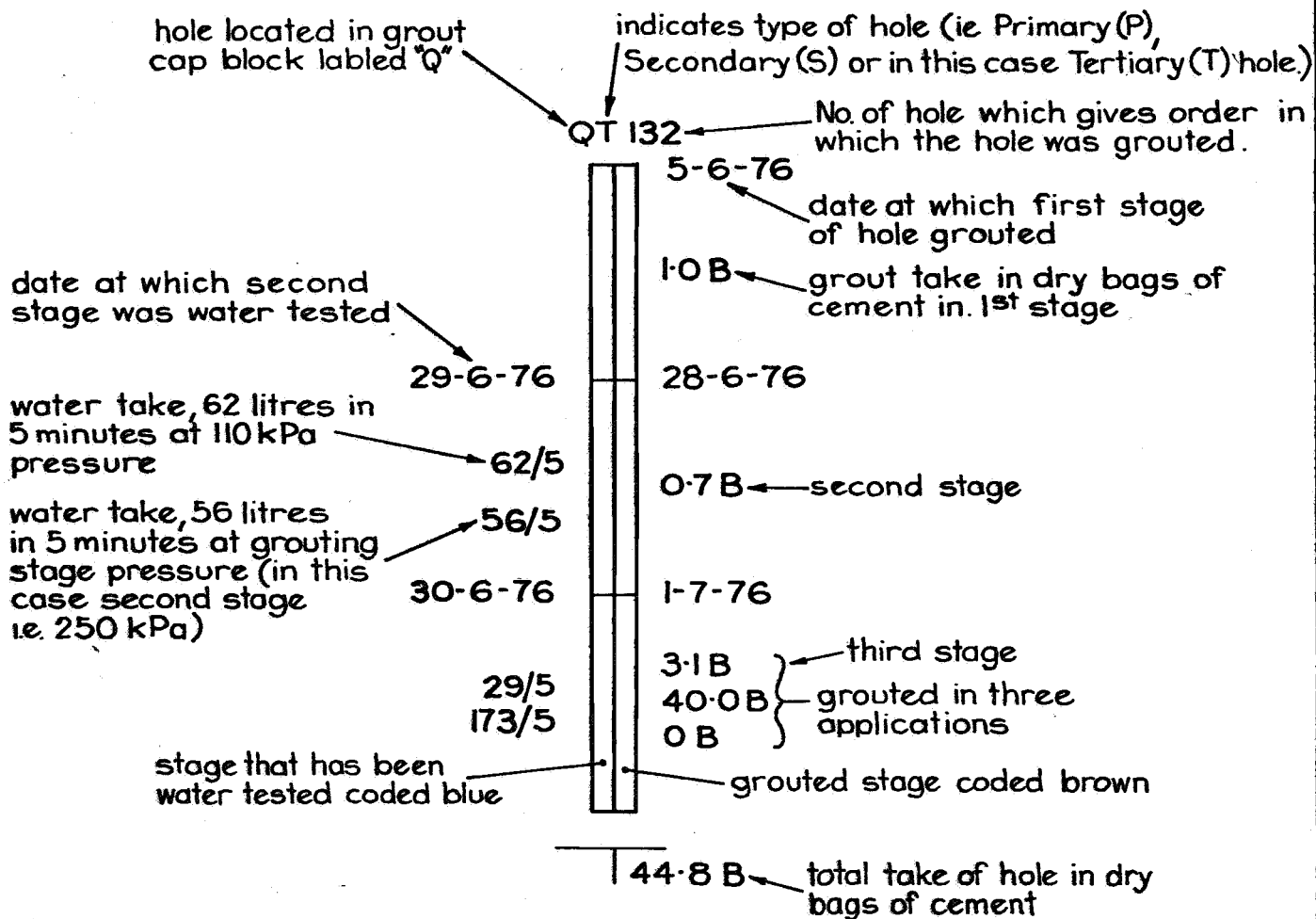
Day THURSDAY
Date 14/10/76
Shift DAY

HOLE NO.	TIME			STAGE			W/C BY VOL.	GROUT TO MIXER IN BAGS	GROUT (LITRES)			NET GROUT TAKE L	WASTE L	PRESSURE AT INTAKE (kPa)	REMARKS: RATE OF TAKE, WASTE DETAILS, LEAKS, etc.	
	FROM	TO	PERIOD (MIN.)	NO.	FROM (m)	TO (m)			IN TANK		INJECTED					
									START	FINISH						
SP236	10.05	10.08	3	2	10	20	3:1	-	90	0	90	1210		0	1301 IN LINES 101 Lost at RMP	
	10.12	10.16	4				3:1	3	280	0	280			0		
	10.20	10.24	4				3:1	3	280	0	280			50		
	10.28	10.32	4				3:1	3	280	0	280			150		
	10.38	10.42	4				3:1	3	280	0	280			120		
	10.52	10.54	2				1:1	4	172	0	172			150		
	11.06	11.21	15				1:1	6	240	120	120			292		200-250
	11.21	11.36	15				2:1	-	457	360	97			250		PUMP LABOURING THINNED DOWN TO 2:1
	11.36	11.51	15				2:1	-	360	356	4			101		250
								22				1603				

TABLE 16 Foundation Grouting Report

TABLE 17

SUMMARY OF GROUT HOLE DATA



TYPICAL GROUT TAKE CALCULATION

eg SP236 - 2nd stage (10-20 m)

Total 3:1 take = 1210 litres

$$= \frac{1210 \times 0.29}{26.5} = 13.2 \text{ Bags}$$

no. of litres dry cement per litre of grout at 3:1

no. of litres of dry cement per bag of cement

Total 1:1 take = 292 litres

$$= \frac{292 \times 0.67}{26.5} = 7.4 \text{ Bags}$$

no. of litres of dry cement per litre of grout

Total 2:1 take = 101 litres

Volume of hole = 36 litres

Net 2:1 take = 65 litres

$$= \frac{65 \times 0.4}{26.5} = 1.0 \text{ Bags}$$

no. of litres of dry cement per litre of grout at 2:1

Total take = 21.6 Bags

CURTAIN GROUTING

Sequence of Grouting

The type of grouting generally used was downstage nipple grouting with the depth of stage and grouting pressure summarized below. This was adhered to, in general, except for places on the right abutment where uplift necessitated a revision in grouting method.

1st stage	0 - 7 m	110 KPa
2nd "	7 - 14 m	250 KPa
3rd "	14 - 21 m	500 KPa

All drilling was carried out using two Atlas Corp. light-weight, pneumatic. water flush, percussion drill rigs powered by a 350 c.f.m. compressor. As a back up an air track drill powered by a 600 c.f.m. compressor was available.

The drilling and grouting was done in successive operations, consisting in each case of drilling the hole to a limited depth (in this case 0 - 7 m), washing, water testing and then grouting of that hole. If the grout take was less than 1 bag of dry cement, the hole was washed out after 2 - 3 hours to allow redrilling the hole to the next stage (7 - 14 m) followed by water testing and subsequent grouting of the new stage. The process was repeated for the third and final stage (14 - 20 m). See Figure 39 for a summary of this process. The holes were washed out under pressure using a length of 1" diameter, Nyllex Class 50B, PVC hose being worked from the bottom to the top of the hole until the flushing water became clear.

The drilling and grouting was started at the bottom of the valley and worked up the abutments in the method outlined as follows. The downstream row of grout holes for the grout curtain was drilled first and before the drilling of any hole on the upstream line was permitted, the downstream curtain had to be closed, in general, a distance of 15 metres from that hole (see Figure 40). The general criteria for closure of the curtain was that the added grout takes, recorded in bags of dry cement, of adjacent stages, should not exceed two bags.

This criteria of a two bag limit was later changed to a limit of five bags in the third stage near the top of the right abutment.

The first grout holes drilled were primary holes spaced at 6 m and were drilled and grouted one stage ahead of intermediate (secondary) holes. These intermediate (secondary) holes were drilled and grouted one stage ahead of further intermediate (tertiary) holes. This process was repeated for further intermediate (eg. quaternary, quinary), holes as required for closure of the curtain. Secondary holes were mandatory but additional holes were normally only required where the take in adjacent secondary hole stages exceeded the limits indicated early in this clause.

Water Testing Procedure

Each stage of a hole was tested for ten minutes; the first five minutes tested at 110 KPA and the next five minutes at the relevant grouting stage pressure. The former five minute test was intended to give some comparison between holes irrespective of location on the grout cap while the latter five minutes gave some indication of probable grout takes in the particular stage and also helped to wash out adjacent seams.

Grouting Procedure -

- Regions where uplift was not expected

This situation corresponded to the bottom area of the right abutment (blocks H, J, K, and L) and the entire left abutment. In general, each hole was started with an initial mix of 5:1 (five parts water to one part Portland cement, by volume) with a maximum of ten bags of dry cement added before thickening the mix to 3:1. This initial mix was contrary to specification, which indicated a starting mix no weaker than a water cement ratio by volume of 2 to 1. If the take was high at 3:1 the mix would be quickly thickened further to 1:1 and grouting continued until hole refusal. The hole was said to reach refusal when the hole took less than or equal to 10 litres of grout (7 bags at 1:1) in a 15 minute grouting period. If the water test revealed there would be a very high take in a hole, the start mix used was 3:1 or 2:1 and then quickly thickened to 1:1 which was continued until refusal was reached.

The thinnest start mix used was a w/c ratio of 5:1 and the thickest end mix was 1:1. The end mix of 1:1 was determined from the fact that this was the thickest grout that the paddle mixer could satisfactorily mix.

Regions where uplift occurred

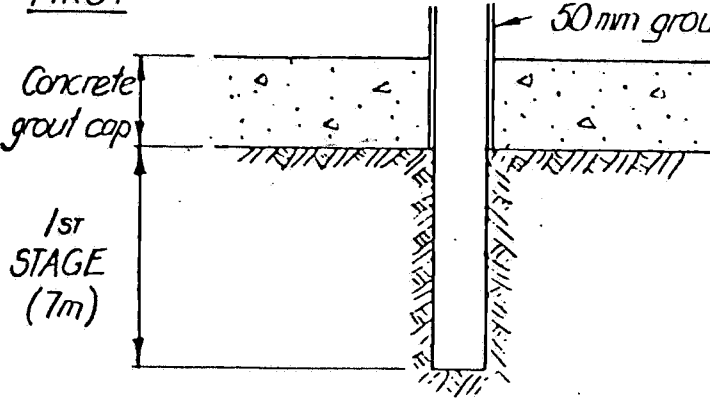
This region was confined to the upper half of the right abutment. As shown in Figure 42, the quartzite band underneath the groutcap feathers out at the top of the right abutment. Between the quartzite and the underlying dolomite is a band of weathered dolomitic siltstone susceptible to solution cavities. In addition a shear zone, open joints and open bedding planes were discovered through blocks M & N and uplift was observed when these blocks were grouted using the normal pressures. Accompanying this uplift very high takes were observed and a great number of additional holes were required in an attempt to close the grout curtain in this area (including blocks P and Q).

It was decided to lower the grouting pressures, change the stage depths and grouting procedure to minimise uplift and still ensure that the country was effectively grouted (see Figure 41). The start mix was changed to a w/c ratio of 3:1 to ensure localized grouting of the area around the hole instead of driving a thinner grout (ie. 5:1 mix) long distances from the curtain. This method effectively reduced the grouting time for holes with large takes while still sealing the larger fractures and solution cavities in the foundation. No further indication of uplift on these blocks was observed.

In addition to using downstage nipple grouting, upstage packer grouting was used in some Tertiary and Quaternary holes to check closure of the curtain when the take of a particular stage was of interest or to locate a crack by movement of the packer up the hole. A plan summary of the major grout takes is shown in Figure 43.

DOWNSTAGE GROUTING WITHOUT PACKING

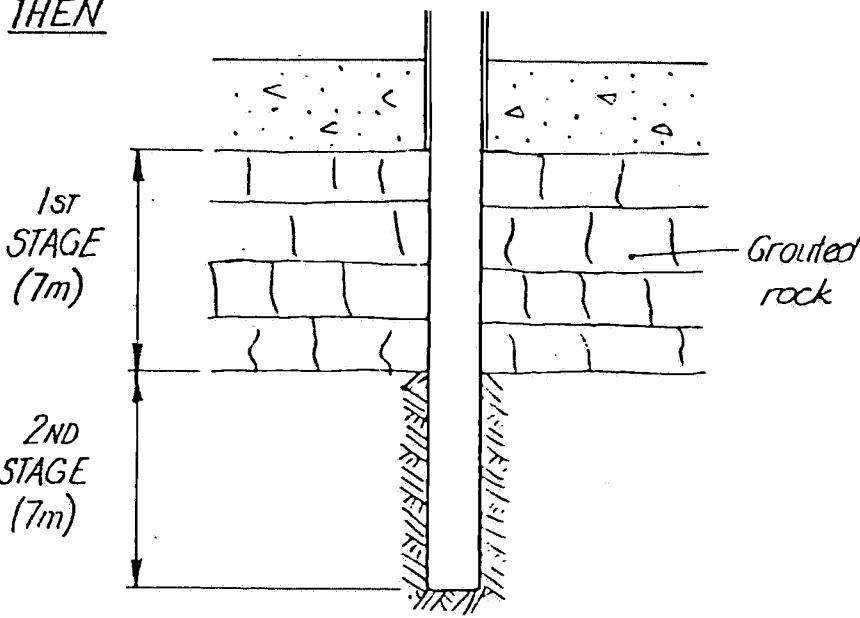
FIRST



50 mm grout pipe encased in grout cap

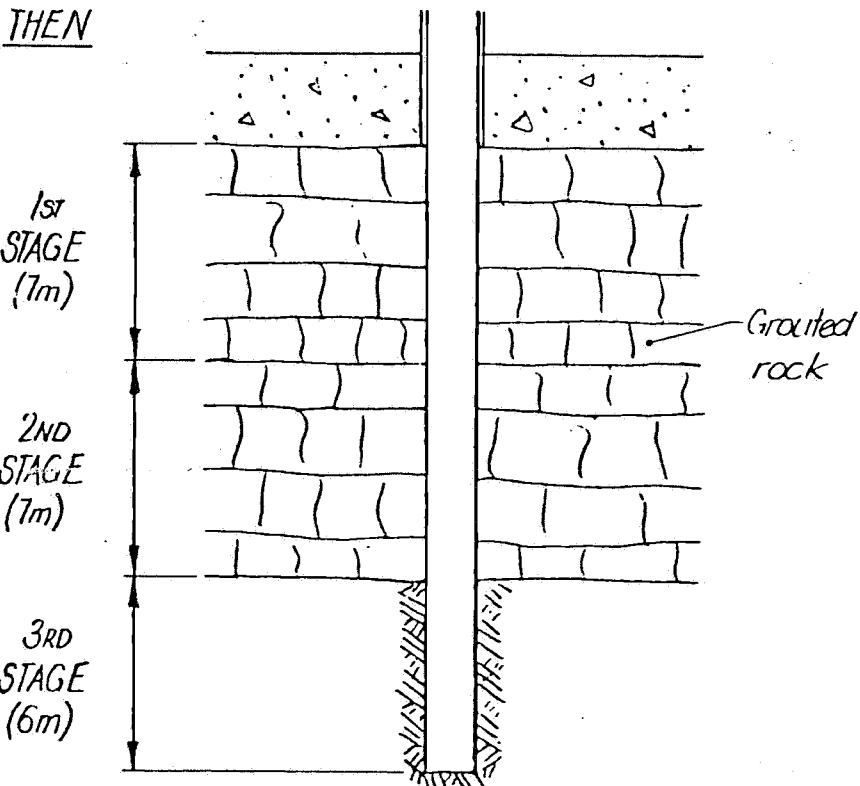
DRILL FIRST STAGE
 THEN WASH HOLE
 WATER TEST HOLE
 GROUT HOLE
 WASH IT OUT (if grout take < 1B)

THEN



DRILL SECOND STAGE
 THEN WASH HOLE
 WATER TEST HOLE
 GROUT HOLE
 WASH IT OUT (if grout take < 1B)

THEN

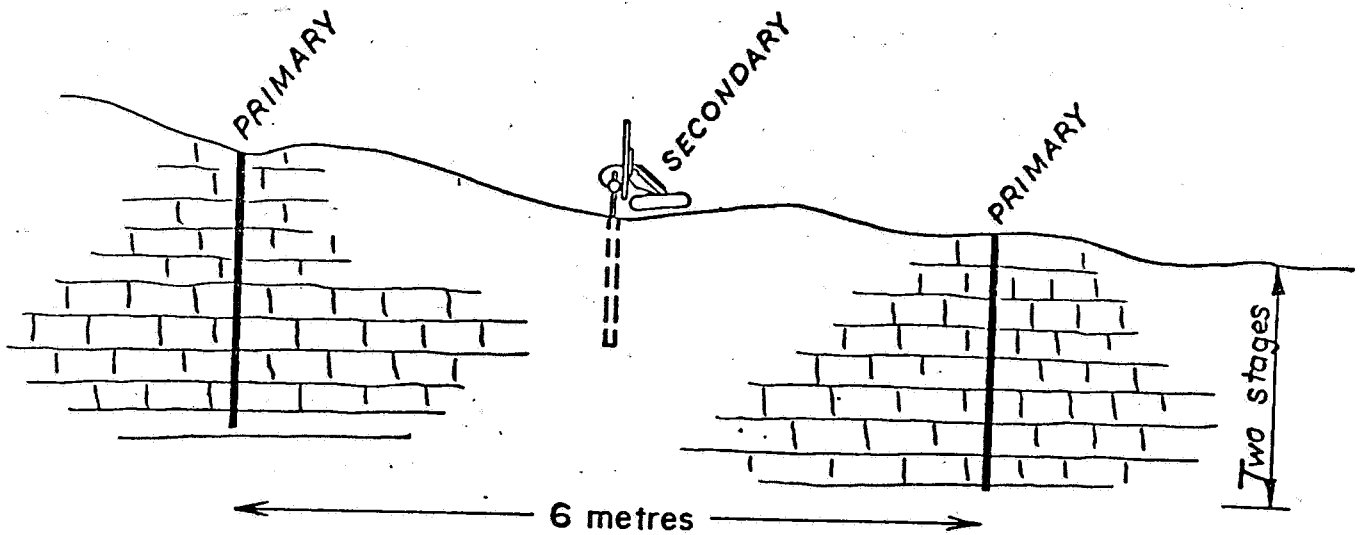


DRILL THIRD STAGE
 THEN WASH HOLE
 WATER TEST HOLE
 GROUT HOLE
 LEAVE HOLE FULL OF GROUT

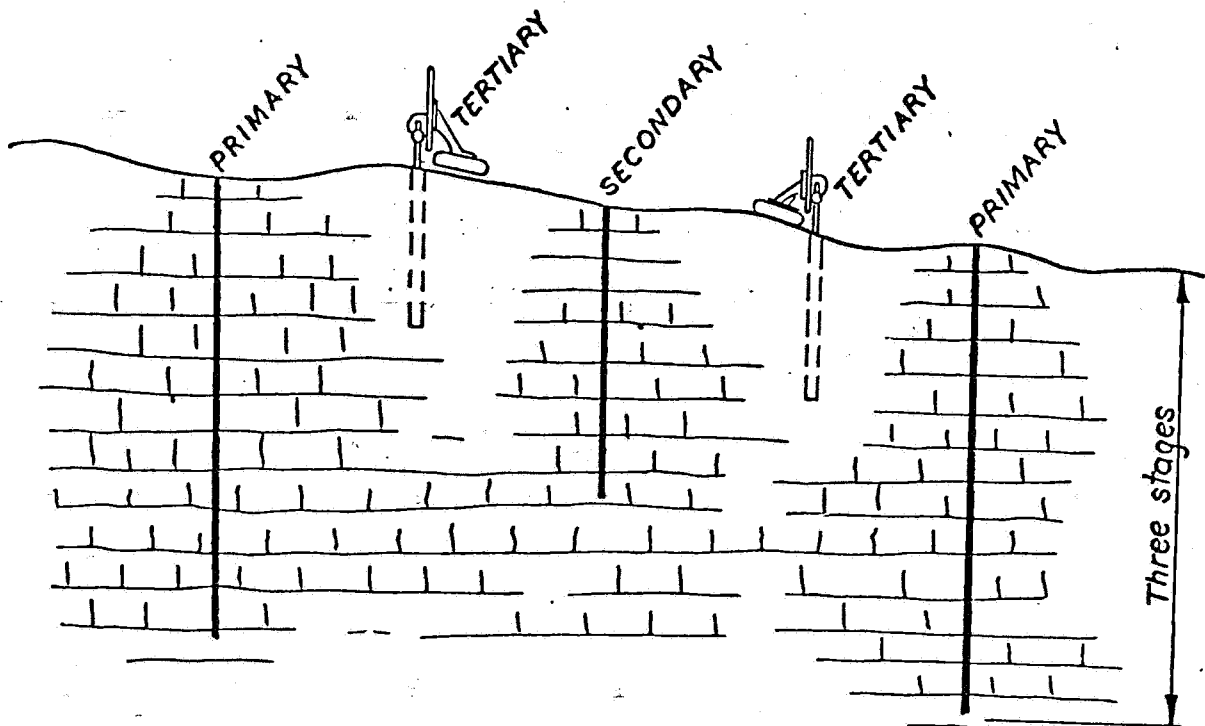
FIG. 39

for each stage grout is injected from the nipple on the standpipe attached to the grout pipe

TYPICAL DRILLING SEQUENCE FOR DOWNSTAGE GROUTING



Two stages of adjacent Primary holes have been completed (in this example). Drilling can therefore start on first stage of the Secondary hole.



Two stages of Secondary hole have been completely grouted
Drilling can therefore start on first stage of the Tertiary hole and similarly for later sequences

(In general the secondary holes were closed before tertiary holes were commenced)

GENERAL RULE

STAY ONE COMPLETED STAGE BEHIND PREVIOUS HOLES

RIGHT ABUTMENT DRILLING AND GROUTING PROCEDURES

3 STAGES

Stage	Depth	Grouting Pressure
<i>Primary, Secondary, Tertiary Holes</i>		
1	0-7 m	110 kPa
2	7-14 m	250 kPa
3	14-20 m	500 kPa
<i>Quaternary & Higher Order Holes</i>		
1	0-7 m	110 kPa
2	7-14 m	250 kPa
3	14-20 m	250 kPa

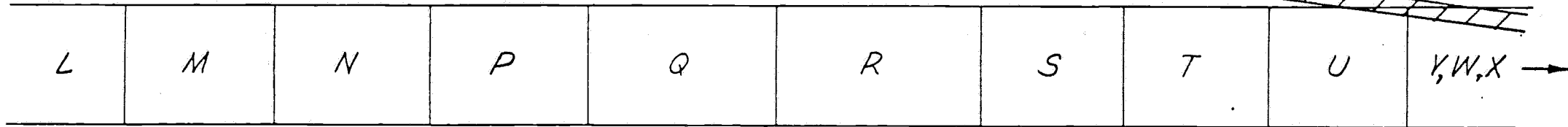
2 STAGES

Stage	Depth	Grouting Press.
1	0-10 m	150 kPa
2	10-20 m	350 kPa
<i>All Holes</i>		

2 STAGES

Stage	Depth	Grouting Press.	
		<i>Block S</i>	<i>T, U, V, W, X</i>
1	0-10 m	150 kPa	110 kPa
2	10-20 m	250 kPa	250 kPa
<i>All Holes</i>			

DOWNSTREAM ROW



UPSTREAM ROW

UPSTREAM ROW
AS ABOVE

UPSTREAM ROW
AS ABOVE

UPSTREAM ROW
AS ABOVE

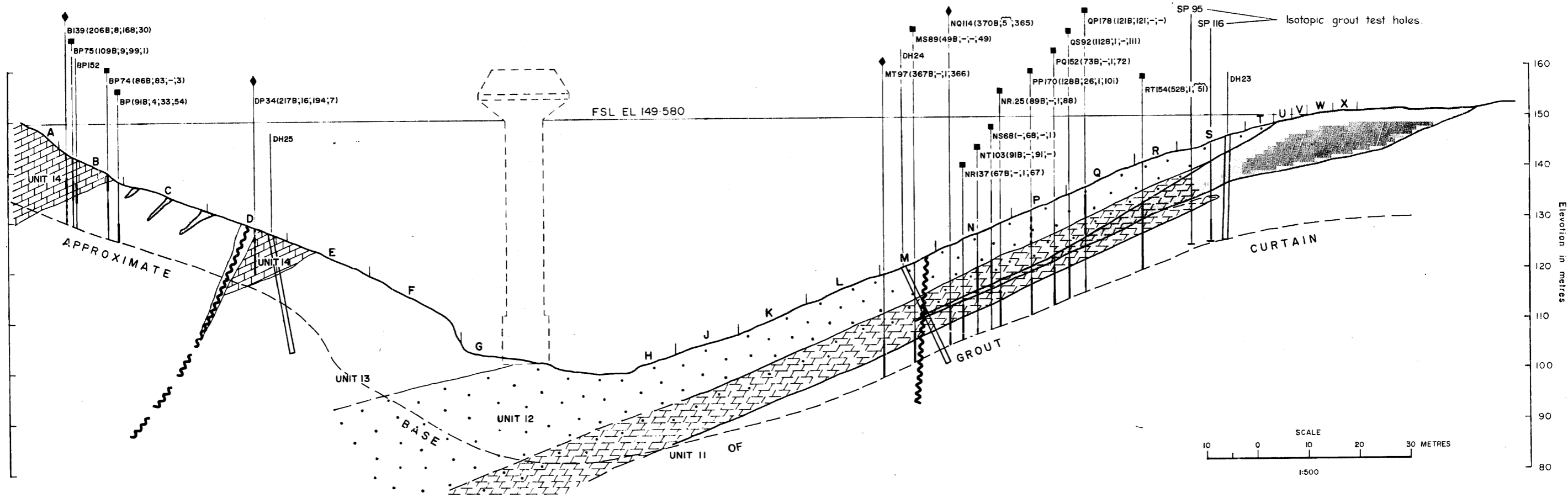
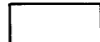





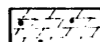



Fig. 42

LEGEND

- | | | |
|---|--|---|
|  DOLOMITIC SILTSTONE |  DOLOMITIC SILTSTONE - COMPLETELY WEATHERED |  >200 BAGS (cement) |
|  SLATY DOLOMITIC SILTSTONE |  QUARTZITE |  50-200BAGS (cement) |
|  TRANSITIONAL STRATA (DOLOMITIC SILTSTONE & QUARTZITE) |  SHEAR ZONE | |

DEPARTMENT OF MINES - SOUTH AUSTRALIA			
LITTLE PARA DAM			
GEOLOGICAL CROSS SECTION			
SUMMARY OF MAJOR GROUT CURTAIN TAKES			
COMPILED J. BEAL	DRN I.M.	SCALE 1:500	PLAN NUMBER
DIRECTOR OF MINES	CKD	DATE 9-11-77	77-1001

112C

Supplement One

Water Pressure Test Results on Check Hole DH 24

- . Log of DH 24
- . Example of Data recording form
- . Lugeon Values for DH 24 (Figure 44)
- . Calculation of Lugeon Values from effective pressure (Figure 45)

PROJECT: *LITTLE PARA DAM*

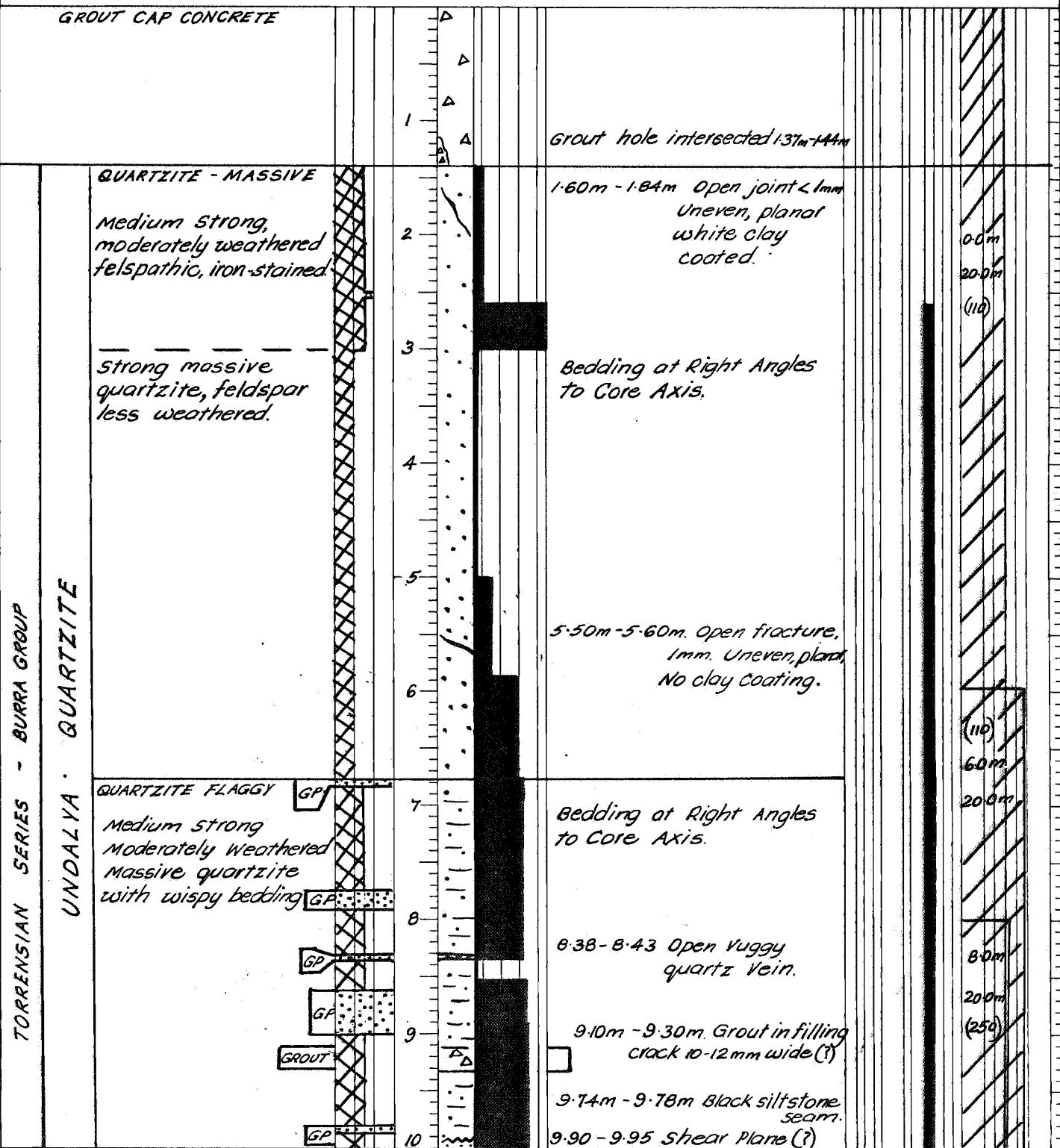
LOCATION OR CO-ORDS: *GROUT CURTAIN CHECK HOLE BLOCK 'M'*

LOG OF DIAMOND DRILL HOLE

HOLE NO. *DH 24*
UNIT/STATE NO. *6628280EWO4130*
SERIAL NO. *624/77*
FOLDER NO. *055241*

SEC. _____ HD. _____ EL Surface _____ EL ref. point _____ Datum _____

GEOLOGICAL DESCRIPTION OF CORE	GROUP SYMBOL	STRENGTH TERM	HOLE DIA	DEPTH m	GRAPHIC LOG	R.Q.D. %	STRUCTURES JOINTS, VEINS, SEAMS, SHEARED ZONES, CRUSHED ZONES	LIFT CORE LOSS %	WATER LEVEL	CASING	DRILL WATER LOSS %	WATER PRESSURE TESTS LUGEONS
								10	DATE	0 100	0.5 5 10 50	



① ROCK SUBSTANCE

STRENGTH TERM
VS-Very Strong
S-Strong
MS-Medium Strong
W-Weak
VW-Very Weak
SO-Soil properties

CONDITION TERM
Fresh
Weathered
Altered
Soil properties

Numbers give diametral point load strength (Is) in MPa.

③ ROCK QUALITY DESIGNATION

0-25% Very poor
25-50% Poor
50-75% Fair
75-100% Good to excellent

④ (350) Maximum effective pressure (kilopascals) reached during test.

DRILL TYPE <i>E 1000</i>	LOGGED BY: <i>J.C. BEAL</i>
CIRCULATION: <i>WATER</i>	DATE: <i>22-6-77</i>
HOLE ANGLE: <i>70°</i>	BEARING: <i>358°</i>
START: <i>20-6-77</i>	TRACED BY: <i>D.W.W.</i>
FINISH: <i>21-6-77</i>	DATE: <i>19-9-77</i>

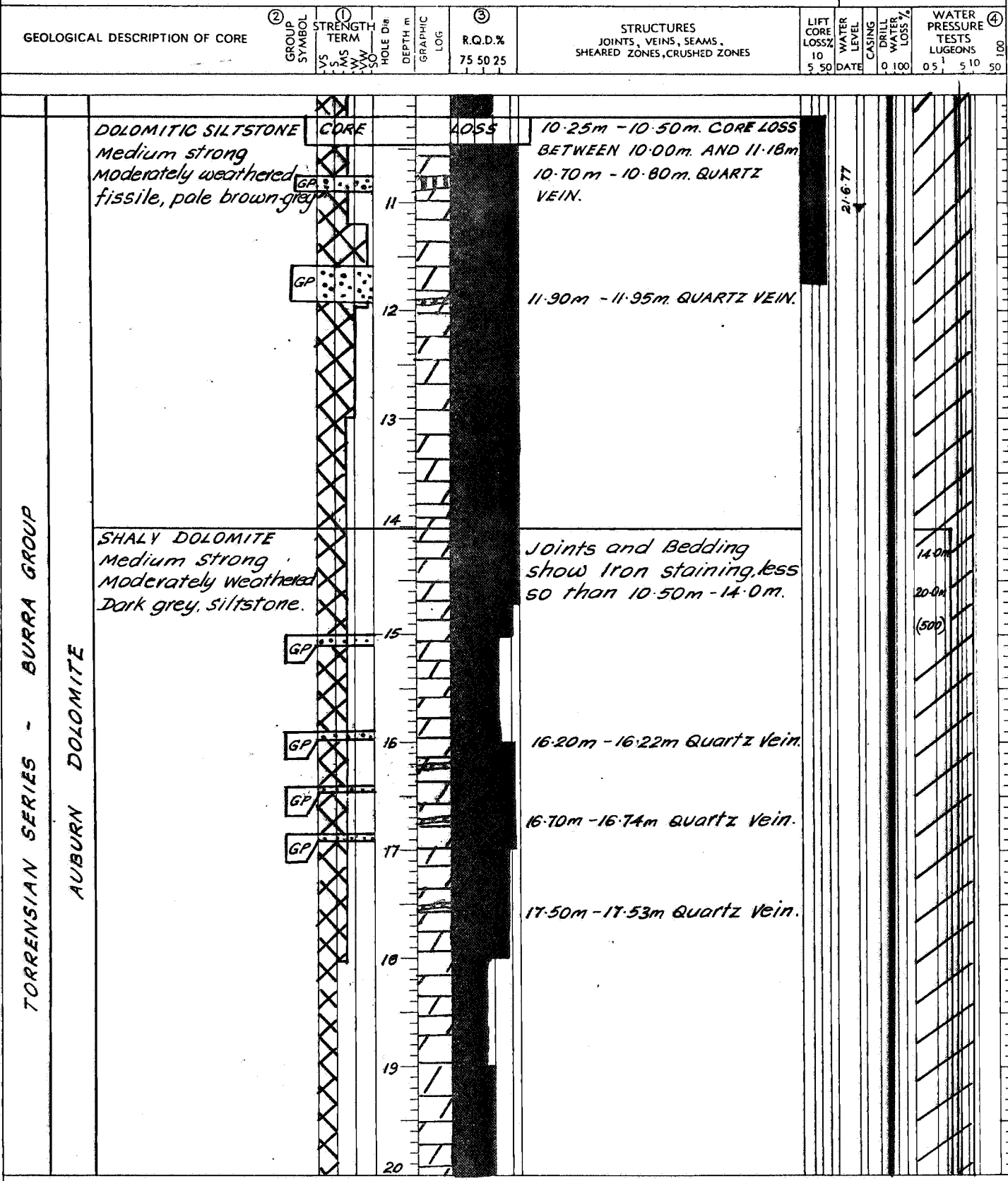
PROJECT *LITTLE PARA DAM*

LOCATION OR CO-ORDS *GRBUT CURTAIN CHECK HOLE
BLOCK 'M.'*

LOG OF DIAMOND DRILL HOLE

HOLE NO. *DH 24*
UNIT/STATE NO. *6628280EW0430*
SERIAL NO. *624/77*
FOLDER NO. *055241*

SEC. HD. EL Surface EL ref. point Datum



TORRENSIAN SERIES - BURRA GROUP
AUBURN DOLOMITE

① ROCK SUBSTANCE

STRENGTH TERM
VS-Very Strong
S-Strong
MS-Medium Strong
W-Weak
VW-Very Weak
SO-Soil properties

CONDITION TERM
Fresh
Weathered
Altered
Soil properties

Numbers give diametral point load strength (1s) in MPa.

③ ROCK QUALITY DESIGNATION

0-25% Very poor
25-50% Poor
50-75% Fair
75-100% Good to excellent

④ (350: Maximum effective pressure (kilopascals) reached during test.

② Substances with soil properties remoulded and classified by Unified System

DRILL TYPE <i>E 1000</i>	LOGGED BY: <i>J.C. BEAL</i>
CIRCULATION: <i>WATER</i>	DATE: <i>22-6-77</i>
HOLE ANGLE: <i>70°</i>	BEARING:
START: <i>20-6-77</i>	TRACED BY: <i>D.W.W.</i>
FINISH: <i>21-6-77</i>	DATE: <i>19-9-77</i>

PROJECT LITTLE PARA DAM		DEPARTMENT OF MINES SOUTH AUSTRALIA ENGINEERING DIVISION		HOLE NO. DH 24
LOCATION OR CO-ORDS GROUT CURTAIN CHECK HOLE BLOCK 'M'		LOG OF DIAMOND DRILL HOLE		UNIT/STATE NO 6628280EW04130
SEC	HD			EL Surface
				SERIAL NO 624/77
				FOLDER NO 055241

GEOLOGICAL DESCRIPTION OF CORE	GROUP SYMBOL	STRENGTH TERM	HOLE DIA	DEPTH, m	GRAPHIC LOG	RQD %	STRUCTURES JOINTS, VEINS, SEAMS, SHEARED ZONES, CRUSHED ZONES	LIFT CORE LOSS %	WATER LEVEL	CASING	DRILL WATER LOSS %	WATER PRESSURE TESTS LUGS, etc.
SHALY DOLOMITE						75 50 25						
End of Hole 20.80m				21								

<p>① ROCK SUBSTANCE</p> <p>STRENGTH TERM</p> <p>VS Very Strong S Strong MS Medium Strong W Weak VW Very Weak SO Soil properties</p> <p>CONDITION TERM</p> <p> Fresh Weathered Altered Soil properties</p> <p>Numbers give diametral point load strength (ls) in MPa</p> <p>② Substances with soil properties remoulded and classified by Unified System</p>	<p>③ ROCK QUALITY DESIGNATION</p> <p>0-25% Very poor 25-50% Poor 50-75% Fair 75-100% Good to excellent</p> <p>④ 3350 Maximum effective pressure (kilopascals) reached during test</p>	<p>DRILL TYPE E1000</p> <p>CIRCULATION WATER</p> <p>HOLE ANGLE 70°</p> <p>START 20-6-77</p> <p>FINISH 21-6-77</p> <p>LOGGED BY J.C. BEAL</p> <p>DATE 23-6-77</p> <p>BEARING</p> <p>TRACED BY D.W.W.</p> <p>DATE 19-9-77</p> <p style="text-align: center;">SHEET 3 OF 3</p>
--	---	--

WATER PRESSURE TEST RESULTS

DEPARTMENT OF MINES - SOUTH AUSTRALIA

LITTLE PARA DAM

(Compiled:)
 CKD.

INTERVAL TESTED	READINGS	TEST No: 6/C DATE 16th Aug., 77 PACKER Single								LUGEON		COMMENTS
		a	b	c	d	e	f	g	h			
9.0 - 10.2m	GAUGE PRESSURE	125	180	250	180	125				a	5	LAMINAR
	EFFECTIVE PRESSURE									b		
	WATER LOSS	14	15	24	20	12				c		
	(10 minutes)									d		
										e		
										f		
										g		

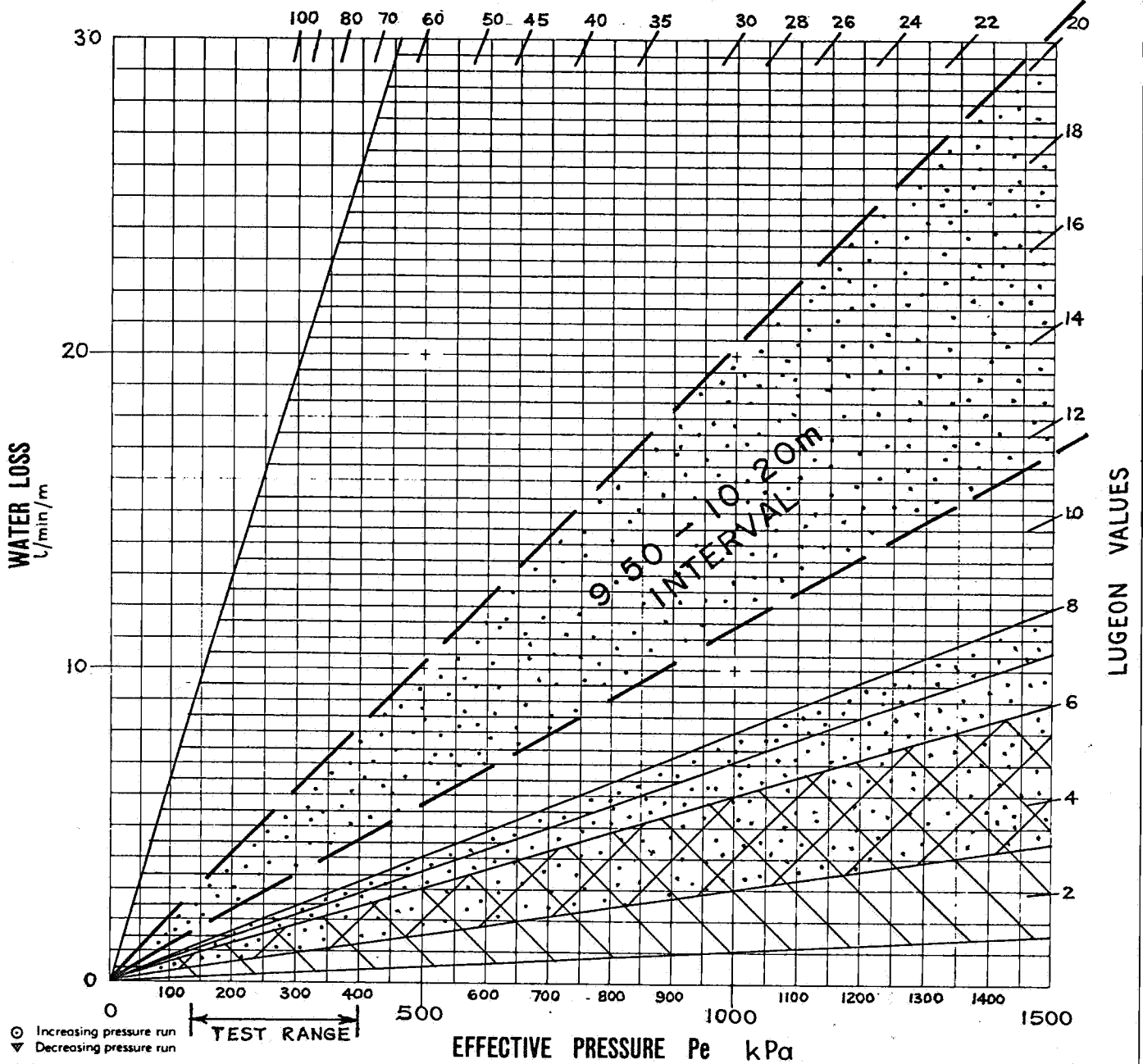
INTERVAL TESTED	READINGS	TEST No: 7/C DATE 17th Aug. 77 PACKER Single								LUGEON		COMMENTS
		a	b	c	d	e	f	g	h			
9.0 - 10.2m	GAUGE PRESSURE	125	180	250	180	125				a	7	LAMINAR ? OR DILATION?
	EFFECTIVE PRESSURE									b		
	WATER LOSS	16.5	23.0	34.0	23.5	15.5				c		
	(10 minutes)									d		
										e		
										f		
										g		

INTERVAL TESTED	READINGS	TEST No: 6/D DATE 16th Aug., 77 PACKER Single								LUGEON		COMMENTS
		a	b	c	d	e	f	g	h			
8.0 - 10.2m	GAUGE PRESSURE	125	180	250	180	125				a	3	DILATION?
	EFFECTIVE PRESSURE	215	270	340	270	215				b		
	WATER LOSS	10	12	28	18	14				c		
	(10 minutes)									d		
										e		
										f		
										g		

INTERVAL TESTED	READINGS	TEST No: 6/E DATE 16th Aug., 77 PACKER Single								LUGEON		COMMENTS
		a	b	c	d	e	f	g	h			
7.0 - 10.2m	GAUGE PRESSURE	125	180	250	180	125				a	3	LAMINAR
	EFFECTIVE PRESSURE	215	270	340	270	215				b		
	WATER LOSS	18	24	35	24	17				c		
	(10 minutes)									d		
										e		
										f		
										g		

PLAN NUMBER
 DATE
 SCALE

WATER PRESSURE TEST · DIAMOND DRILL HOLE



LUGEON RANGE
PRIOR TO GROUTING
(Nipple stand pipe on open hole)
1-6

LUGEON RANGE
Double packer results
interpreted as a single packer
3-6

LUGEON RANGE
AFTER GROUTING
(Single packer in open hole)
3-8
11-20 (Over 9.50m - 10.20m
interval)

LUGEON RANGE
Accepting double packer
results
7-70

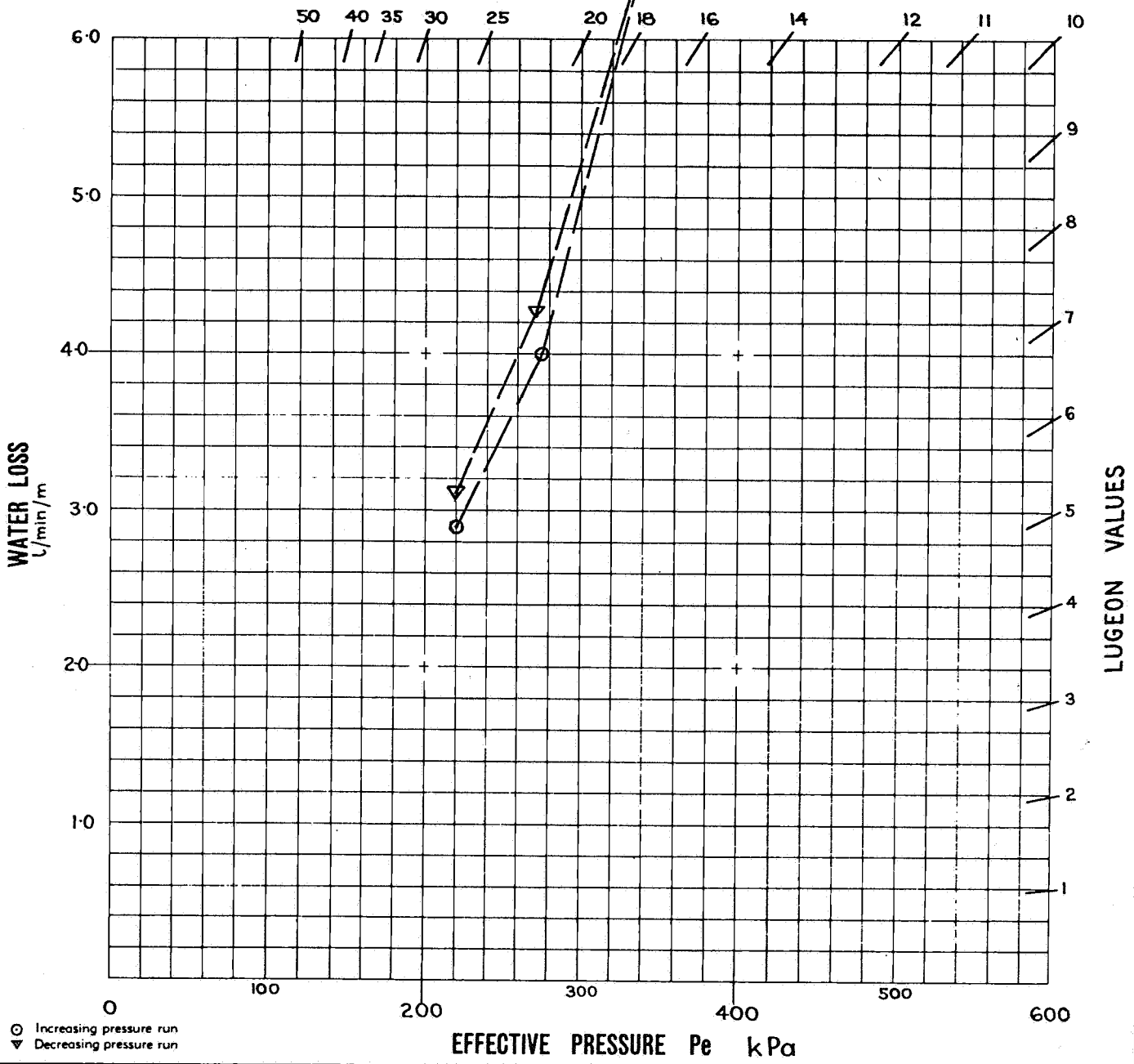
Plan no. S 13885
FIG. 44
J.C. BEAL

WATER PRESSURE TEST · DIAMOND DRILL HOLE

HOLE DH 24
SECTION TESTED
From 9.50. m.
To 10.20. m.
Mean Depth 9.85. m

PROJECT LITTLE PARA DAM
FEATURE GROUT CURTAIN CHECK
LOCATION BLOCK M.

CO-ORDINATES
ANGLE FROM HORIZONTAL 70° (Sine = 0.94) PLANE OF DIRECTION CURTAIN
R.L. Collarmetres Datum



Slope height of pressure gauge above collar 0.65 m
Groundwater level at beginning of shift 9.90 m
Length of test section 0.70 m

WATER COLUMN CORRECTION
Slope height of water column above groundwater level
Below collar 9.85 m
Below pressure gauge, H_w 10.50 m
Extra pressure due to head of water column, P_w 96.81 kPa

GAUGE P_g lb/in ²	PRESSURE P_c kPa*	WATER LOSS			SUPPLY LINE CORRECTION P_s kPa	EFFECTIVE PRESSURE P_e kPa
		gall/min	L/min	L/min/m		
	125		2.0	2.9		222
	180		2.8	4.0	NEGLIGIBLE	277
	250		4.7	6.8		347
	180		3.0	4.3		277
	125		2.2	3.1		222

PACKER TYPE
SINGLE

Date of Test 16.8.77
Test by M. OBST
Calc by J.C. BEAL
Checked D.A.
Drg No S13886

$P_w = H_w \sin \theta \times 9.81$
 $P_e = P_c + P_w - P_s$ For general layout of water pressure tests see Drg No. P_s is obtained from Drg No. 0.006
* 100 kPa (kilopascal) = 1 bar

APPENDIX 2

REPORT ON THE INSTRUMENTATION
OF LITTLE PARA DAM

by

B. ADAMS

(SITE ENGINEER, ENGINEERING & WATER
SUPPLY DEPARTMENT, PUBLIC SERVICE
OF SOUTH AUSTRALIA)

CONTENTS

ABSTRACT

INTRODUCTION

INSTRUMENTS

RESULTS

Figure 46 Arrangement of Instrumentation

Figure 47 Stress Distribution in Outlet Duct
Reinforcement

Figure 48 Embankment Settlement against Time

Figure 49 Stress on Outlet Duct during
Embankment Construction

Figure 50 Embankment Settlement results of Hyd-
raulic Gauge No. 2

THE INSTRUMENTATION OF
LITTLE PARA DAM

ABSTRACT

A total settlement of 350 mm was recorded before the embankment became stable. Post construction settlement on the concrete face to date is 18 mm.

Stress readings of up to 97.47 MPa (tension) and 60.14 MPa (compression) have been recorded in the outlet duct. These figures are within the acceptable limits.

Movements at the grout cap-face slab joints are in the order of 1.0 - 2.0 mm.

INTRODUCTION

Instrumentation of the Little Para Dam has been carried out to provide information on loads, settlement, and horizontal movements of the dam during and after construction. The arrangement of the instruments is shown in Figure 46. The observations include:-

- (i) Settlement, horizontal movement and relative displacement of the upstream face concrete slabs.
- (ii) Settlement and horizontal movement of the downstream face rockfill.
- (iii) Stress distribution in the transverse reinforcing steel of the outlet duct.
- (iv) Loads induced by the rockfill on the outlet duct.
- (v) Internal Settlement of the rockfill.
- (vi) Relative movement in joints between face slabs and grout cap blocks.

Instruments

Survey levelling pins were installed to monitor upstream and downstream face movements. The upstream layout consists of 43 pairs of pins placed 305 mm each side of the slab joints at various levels during and after concreting of the face. It was not possible to place all pins during concreting because the wheels of the dragscreed were in line with the pins. Cored holes were used in these instances and the pins were grouted in after concreting.

The downstream layout consisted of ten pins grouted into suitable size rocks as close to the nominated position as practicable.

Survey triangulation and levelling are used to monitor horizontal and vertical movements of the pins. Relative movement between each pair of pins on the upstream is monitored with an INVAR bar vernier.

Carlson dynamometers were installed to monitor stress distribution in the outlet duct reinforcement. Three gauges were installed on the top face reinforcement and three on the bottom face reinforcement. The instruments are dual coil meters which allow for temperature correction.

Loads induced by the rockfill on the outlet duct were measured with Hall total pressure cells. 18 cells were placed in groups of six, each group placed around the duct as shown. Gas tubes from each instrument were channeled to reading stations in the duct. Operation of the pressure gauges is based on pressure changes of the feed gas (dry nitrogen) to maintain a constant flow rate through a dilating diaphragm.

Each instrument was set into an epoxy mortar paid in a blockout on the outside face of the duct. The height of the sensing face of the instrument above the surrounding concrete was required to be 1.6 mm (± 0.8 mm). The close tolerance was achieved by placing an epoxy mortar annulus around the blockout and screeding this flat with a large steel screed plate. After hardening, the instrument was seated into an epoxy mortar which had been set to the correct height with an interval screeding ring.

The instruments were protected from damage by the rockfill with bedding sand.

Internal settlement of the rockfill is monitored using four hydraulic settlement gauges set out in a grid pattern at approximately EL. 123.5.

The gauges, supplied by Snowy Mountains Engineering Corporation operate on a simple manometer basis. These gauges were set into protective fine grained bedding material on the embankment and connected to the external reading station with nylex duplatube.

The initial level check was carried out after field assembly and placement of the gauges was completed, but before backfilling of protective material. Checking the instruments consisted of pumping de-aired distilled water through the system. When the complete system was full and water levels were steady, in the sight glasses at the reading station, the overflow weir were accurately levelled. When the weir and reading station levels coincided the system was accepted to be air free and reading correctly.

Each gauge had a dual manometer system with two overflow weirs at the gauge, the weirs are set so that there is a 30 mm difference in the overflow level. This difference was designed to check that the system was air free and reading correctly. during normal operation of the gauges. Each tube and weir of a gauge is flushed separately and allowed to settle. When the difference between the two sight glass readings for a gauge is 30 mm then it is assumed that the system is reading correctly.

Joint movements between the grout cap and face concrete are monitored by using Carlson electrical joint meters.

The joint meters are similar in operation to the strain meters used in the duct except that they have a higher range of operation (12 mm). The higher range is made possible by incorporating a set of bellows at the central part of the gauge casing.

The gauge is constructed in two parts, an anchor socket and the strain meter. The anchor socket was placed in position on the first side of the joint to be poured - in this case the grout cap block. When the face slab was ready to be poured the strain meter was screwed into position in the anchor socket and the lead wire run out to the reading station.

Results to Date

Results taken up to September 1978 show a maximum post construction settlement of 18 mm measured at EL. 148 on the upstream face. Five readings beyond this date are to be taken at six monthly intervals.

Downstream face settlement and horizontal movement are given in Figure 47.

As would be expected, bulging and settlement have occurred. Movement is not as extensive in the lower part of the bank (below EL. 108) as it is the central section (EL. 118.138). There appears to be virtually no bulging and only moderate settlement in the higher bank section (EL. 138-148).

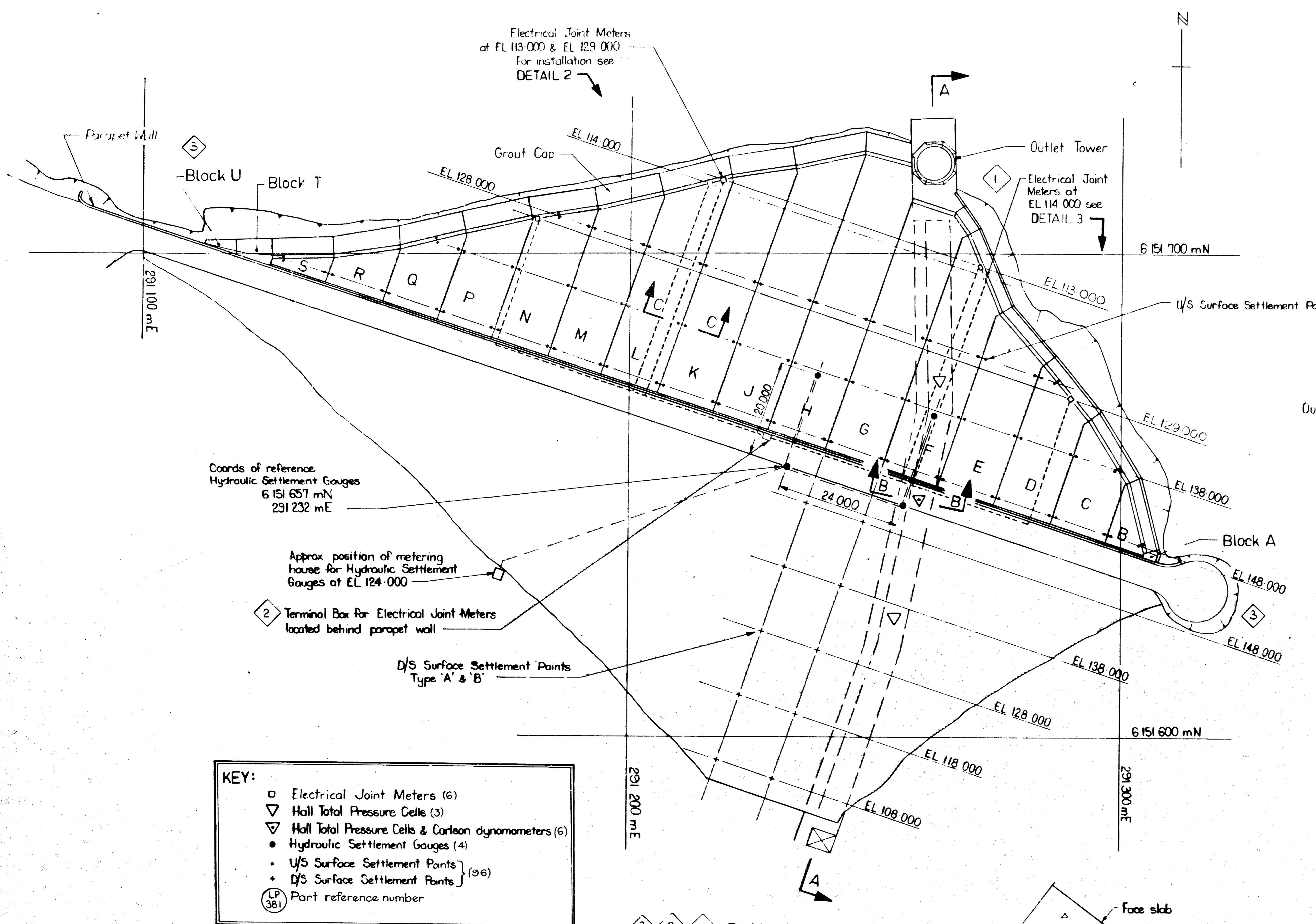
Figure 48 indicates that the rate of settlement of the lower section has reduced since the completion of the bank and also shows that some settlement is still occurring in the upper levels.

Stress distribution in transverse reinforcing steel at the centre reading station in the outlet duct is shown in Figure 49. Data supplied by Design Branch indicate that stresses are within acceptable limits.

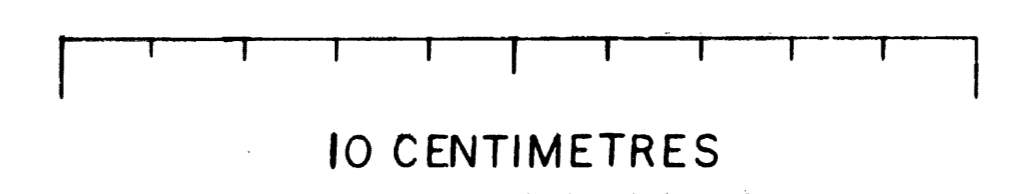
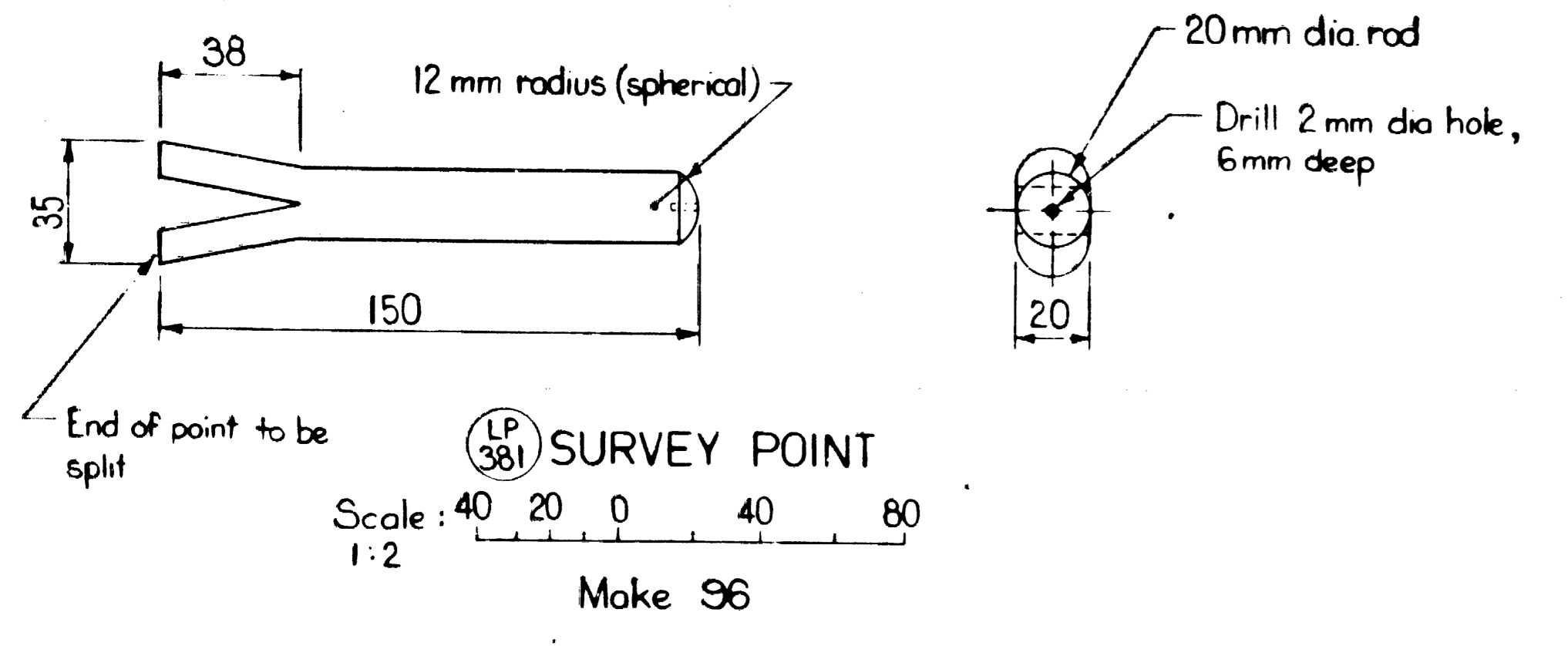
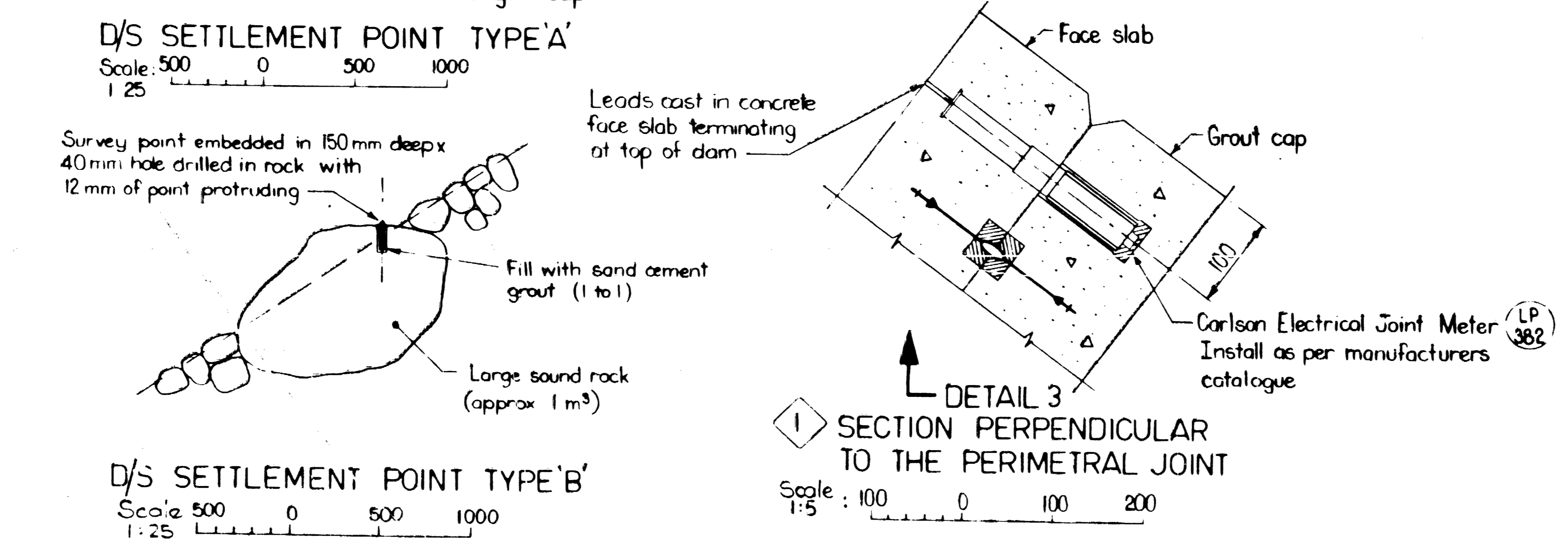
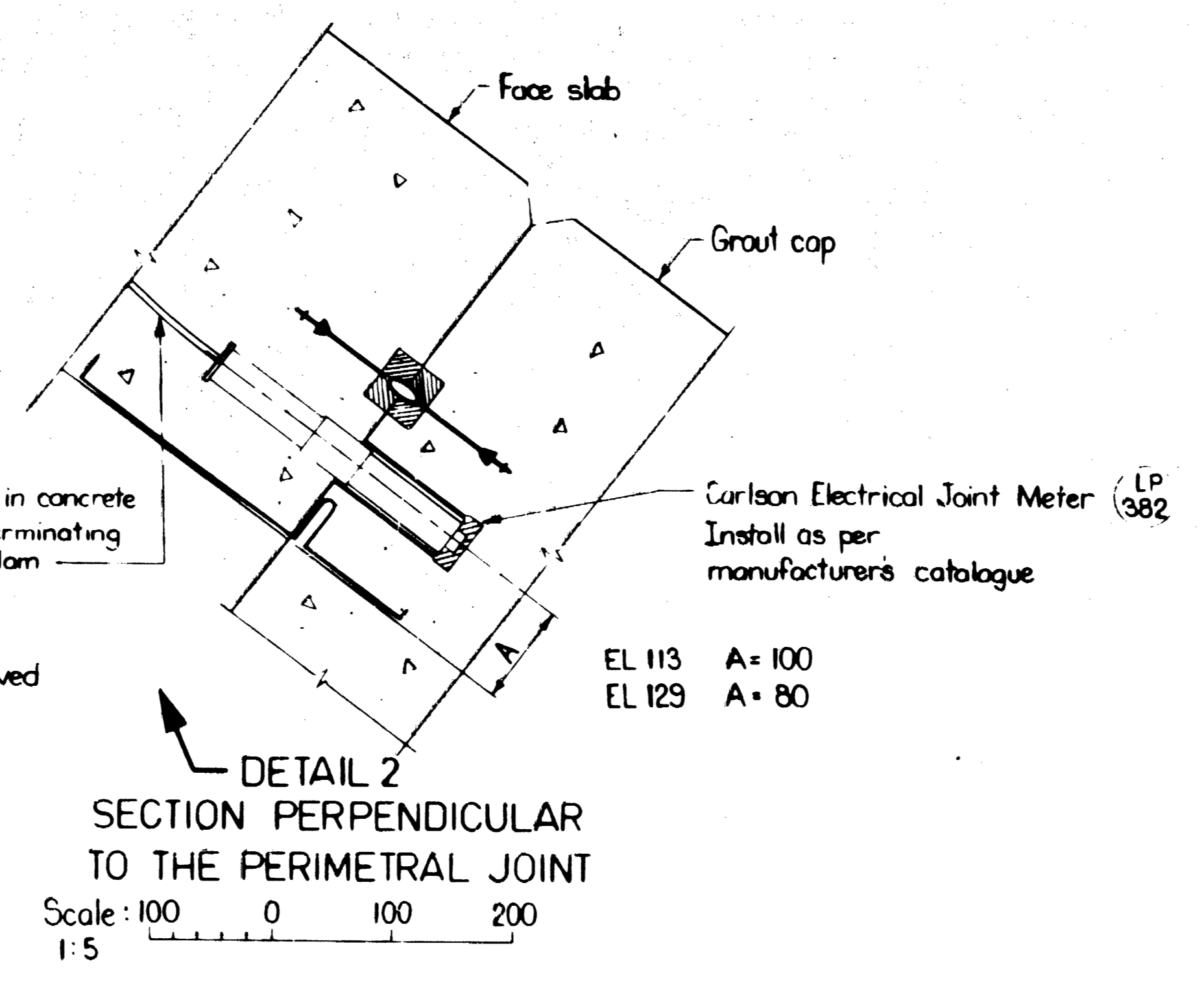
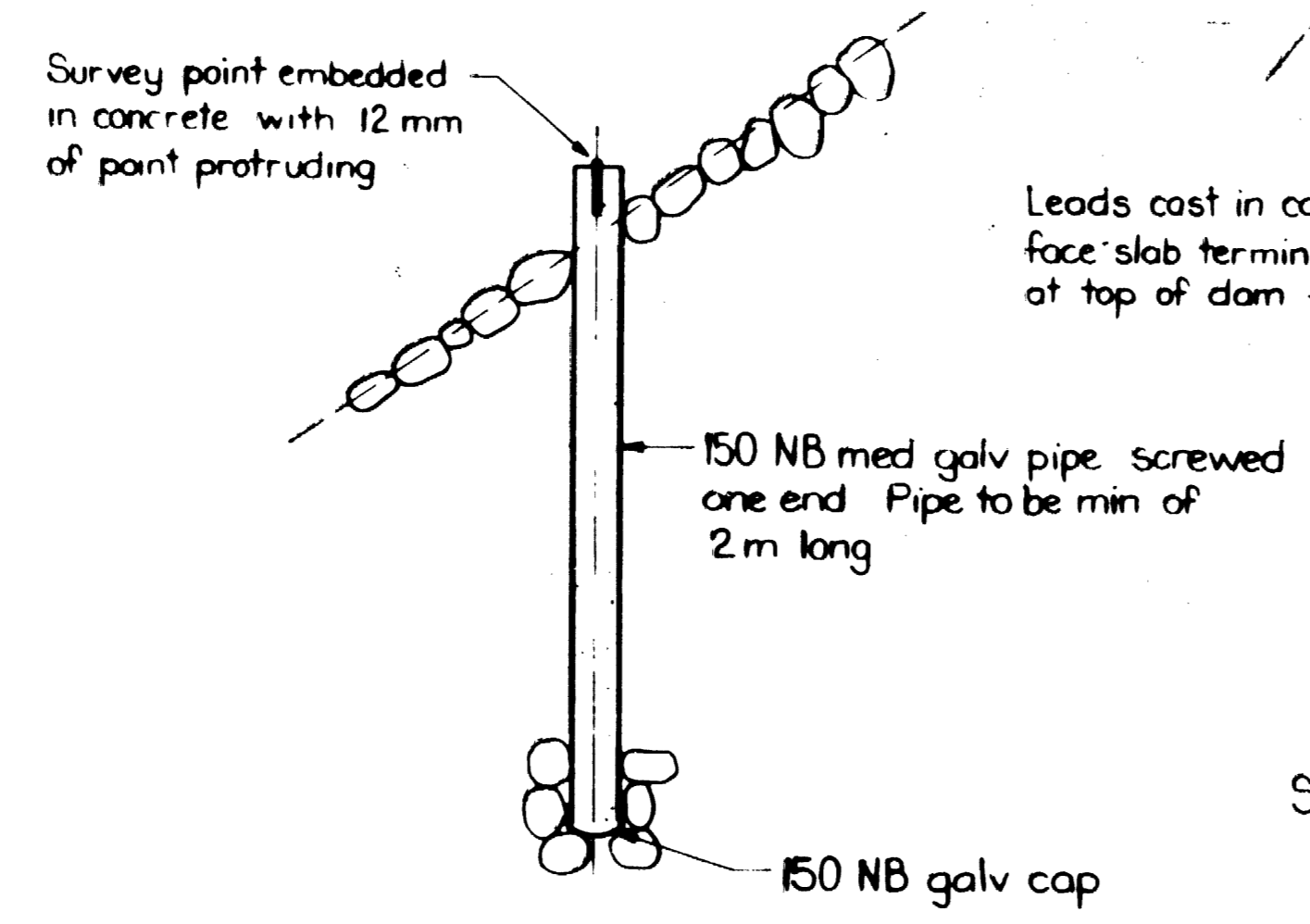
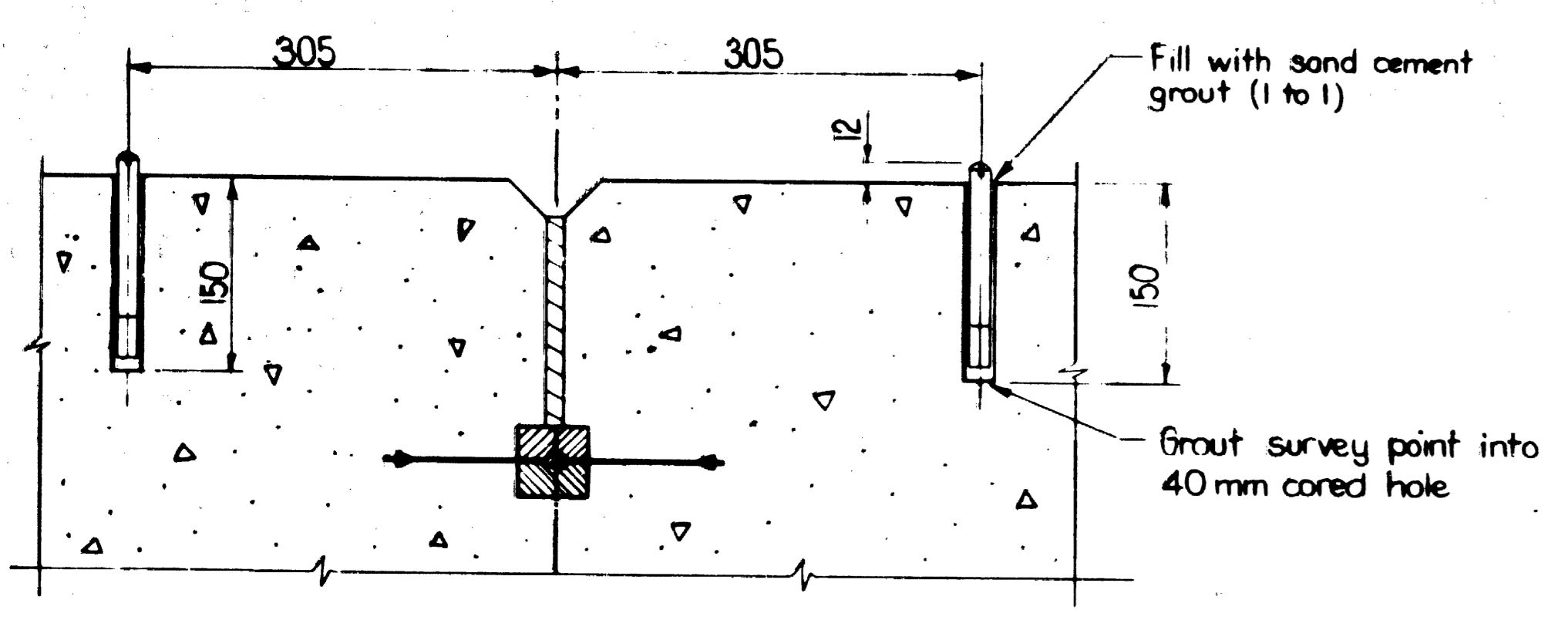
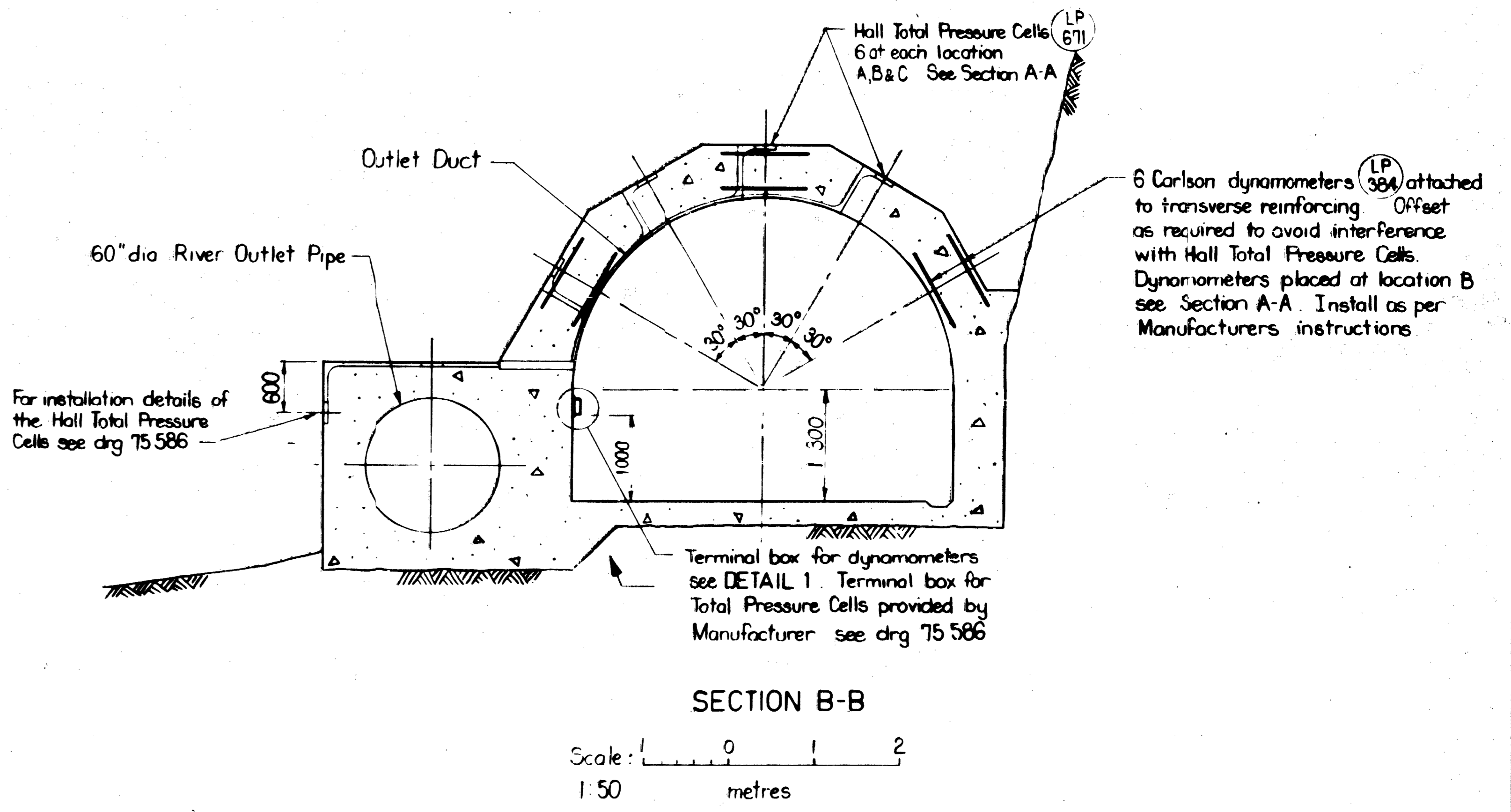
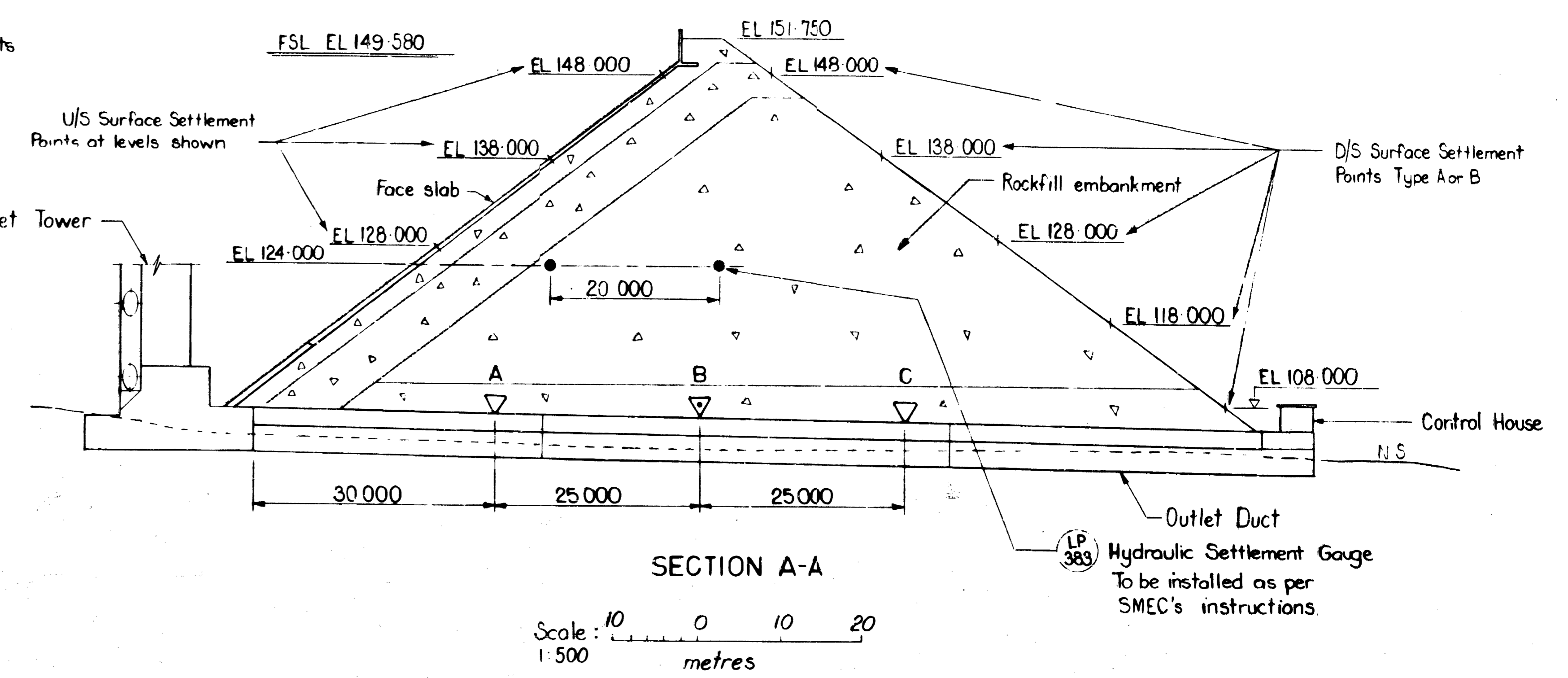
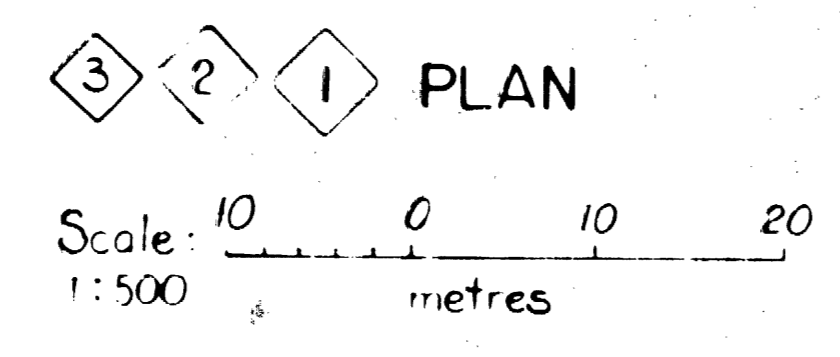
Pressures induced by fill loads, on the outlet duct during construction are shown in Figure 50. A comparison of measured pressure and theoretical pressure indicate construction pressures in excess of the theoretical value, which was based on fill density and embankment height at the time of reading. After embankment completion, measured values have relaxed to a value quite close to the theoretical pressure.

Typical results of fill settlement indicated by the hydraulic settlement gauges are shown in Figure 48. The results indicate that the settlement rate slowed considerably after placement of the embankment was complete, as would be expected for a granular material.

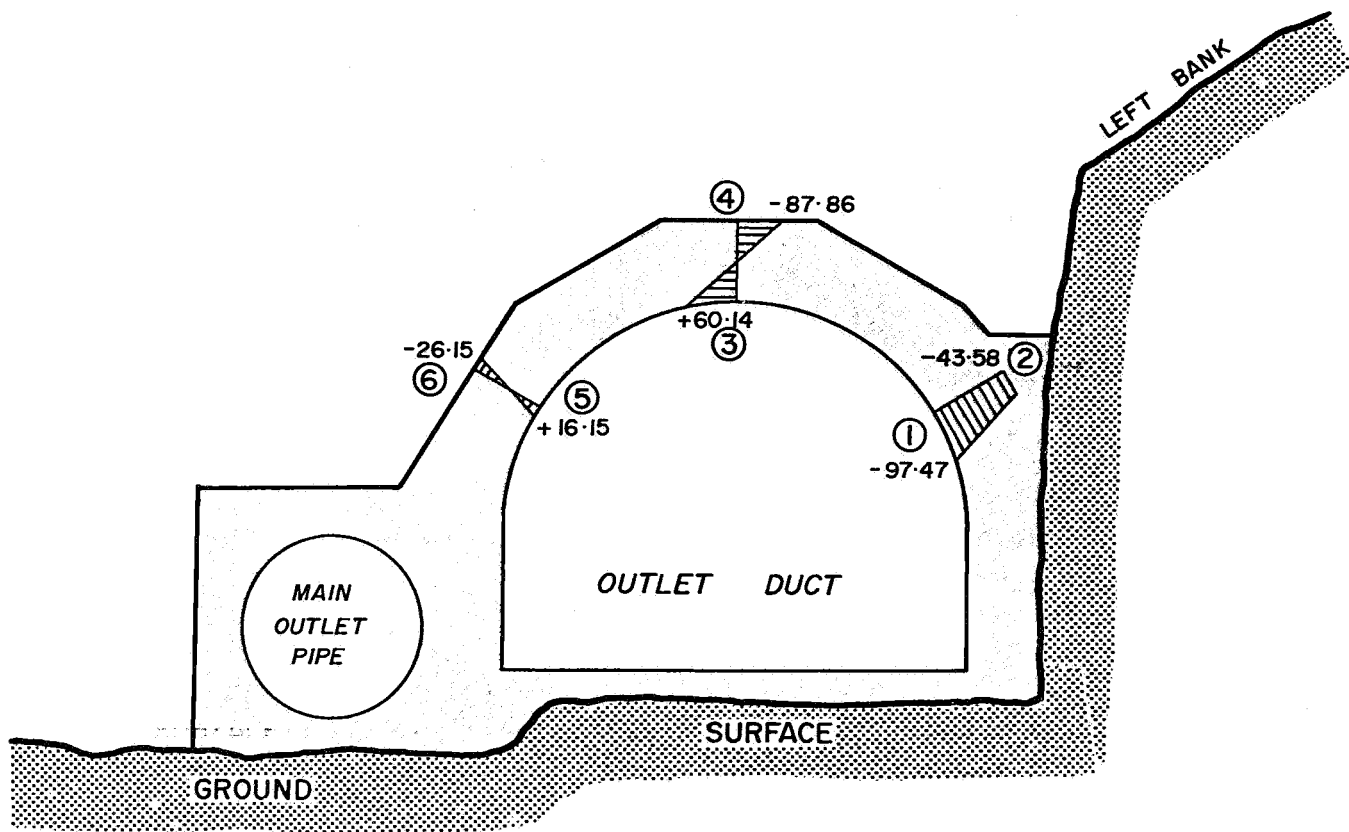
The joint meters indicate movement at the grout cap-face slab joints in the range of 1.0 - 2.0 mm the maximum on Block D at E.L. 128 (July 19th 1978).



- KEY:**
- Electrical Joint Meters (6)
 - ▽ Hall Total Pressure Cells (3)
 - ▽ Hall Total Pressure Cells & Carlson dynamometers (6)
 - Hydraulic Settlement Gauges (4)
 - U/S Surface Settlement Points (26)
 - + D/S Surface Settlement Points (26)
 - Ⓟ Part reference number



DEPARTMENT OF MINES - SOUTH AUSTRALIA				
ENGINEERING SERVICES	COMPILED J.C. BEAL	DRN	SCALE AS SHOWN	PLAN NUMBER
DIRECTOR OF MINES	CKD	DATE SEPTEMBER '76		76-729



LEGEND

Embankment level EL. 147.50m. (A.H.D.)

Water level 000

Date of reading 20.1.77

① Meter number

Stress meter readings (MPa). - Dec. 1977

- ve. : Compression

+ ve. : Tension

FIG. 47

DEPARTMENT OF MINES AND ENERGY
SOUTH AUSTRALIA

SCALE: —

COMPILED: J.C.B.

LITTLE PARA DAM

DATE: MAY 1978

DRN: M.R. CKD:

STRESS DISTRIBUTION IN
OUTLET DUCT REINFORCEMENT

PLAN NUMBER

S 13403

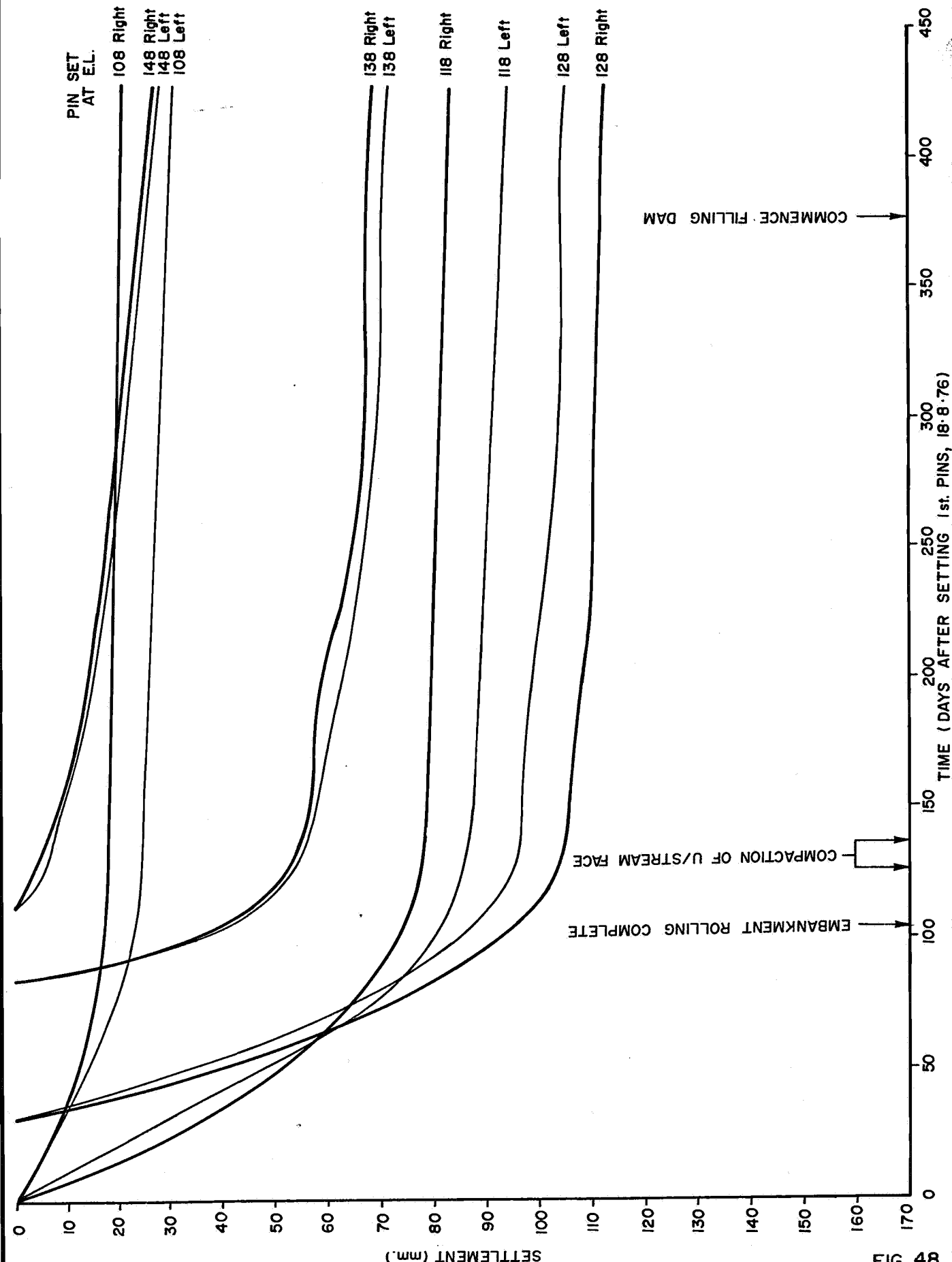


FIG. 48

DEPARTMENT OF MINES AND ENERGY
SOUTH AUSTRALIA

LITTLE PARA DAM
EMBANKMENT SETTLEMENT
VERSUS TIME

SCALE: —

DATE: MAY 1978

PLAN NUMBER
S 13402

COMPILED: J.C.B.

DRN: M.R. CKD:

1126

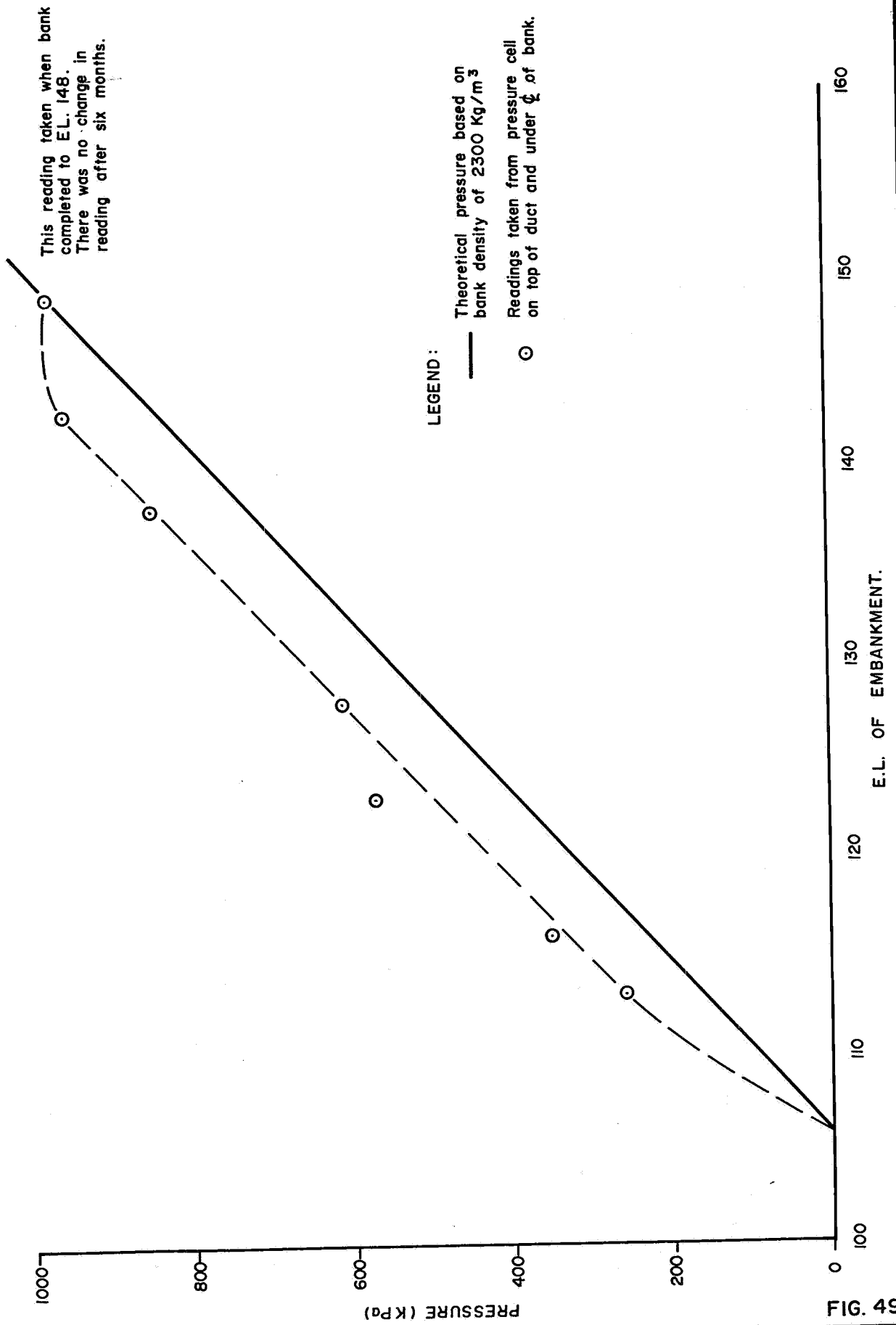


FIG. 49

DEPARTMENT OF MINES AND ENERGY
 SOUTH AUSTRALIA

LITTLE PARA DAM
 LOADS INDUCED BY ROCKFILL ON
 THE OUTLET DUCT DURING CONSTRUCTION

SCALE —

DATE: MAY 1978

PLAN NUMBER

S 13404

COMPILED: J. C. B.

DRN: M.R.

CKD:

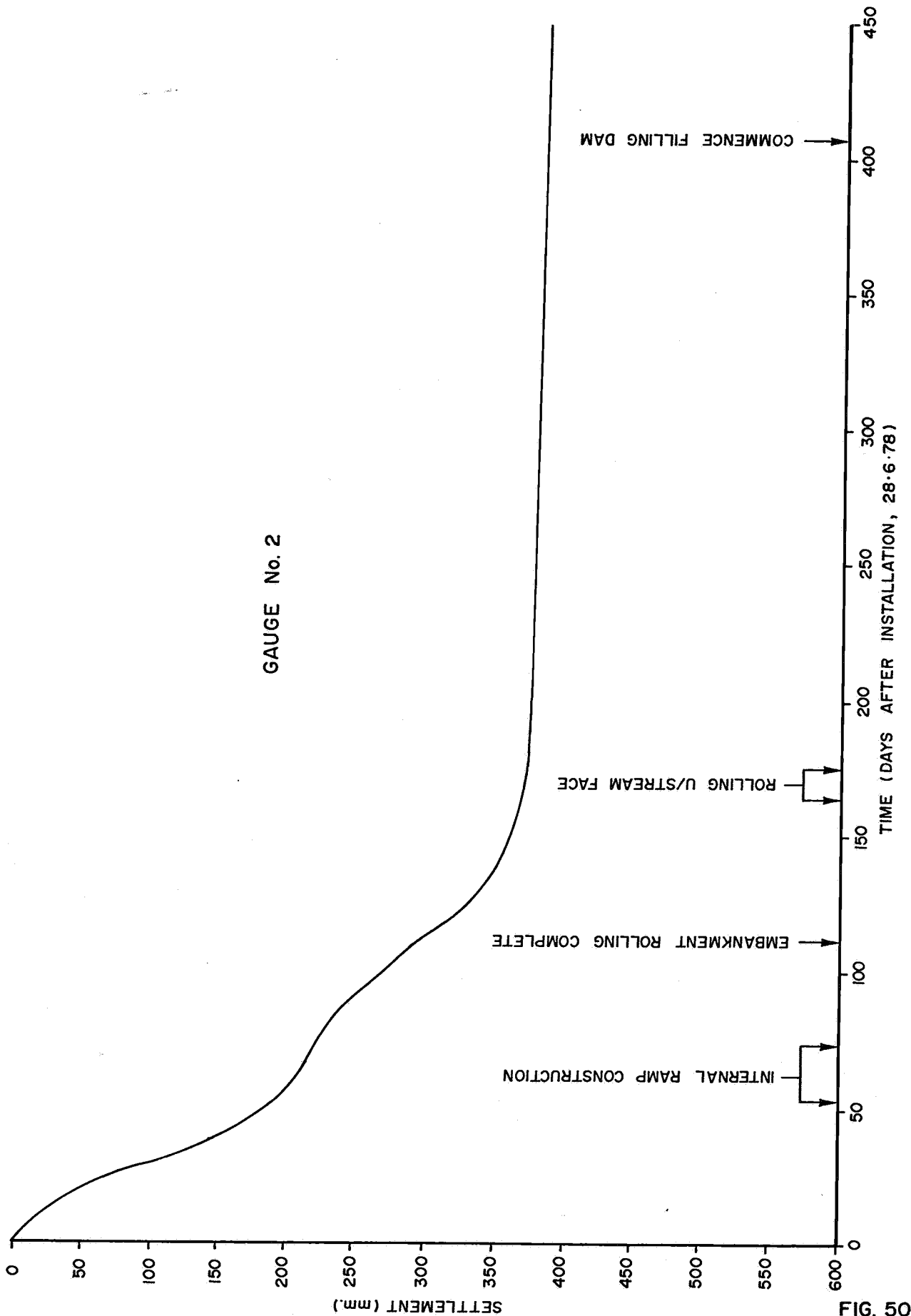


FIG. 50

DEPARTMENT OF MINES AND ENERGY
SOUTH AUSTRALIA

SCALE: —

COMPILED: J.C.B.

LITTLE PARA DAM

DATE: MAY 1978

DRN: M.R. CKD:

EMBANKMENT SETTLEMENT RESULTS
OF HYDRAULIC GAUGE No. 2

PLAN NUMBER

S 13405

APPENDIX 3

REPORT ON SLOPE STABILITY INVESTIGATIONS

by

J.C. BEAL

(GEOLOGIST, DEPARTMENT OF MINES & ENERGY
PUBLIC SERVICE OF SOUTH AUSTRALIA)

CONTENTS

ABSTRACT

INTRODUCTION

HILL SLOPE STABILITY

THE QUARRY

THE SPILLWAY

Table 18: Summary of Fracture Data

Table 19: Factors of Safety

Table 20: Rock Block - Sizes

Figure 51 - Figure 54 - Hoek Shear Box tests

Figure 55 Stereogram - Contoured pole of
Fractures Prior to
Quarry Excavation

Figure 56 Stereogram - Contoured Poles of
Fractures Following
Quarry Excavation

Figure 57 Stereogram - Summary of Main Fractures

Figure 58 The Quarry - Regime Locations

Figure 59 Sterographic Failure Analysis -
Eastern Quarry Batter

Figure 60 Sterographic Failure Analysis -
Central Quarry Batter

Figure 61 Sterographic Failure Analysis -
Western Quarry Batter

Figure 62 Stability Assessment-Quarry Profile

Figure 63 Spillway Fracture Survey.

LITTLE PARA DAM
SLOPE STABILITY INVESTIGATION

ABSTRACT

Hoek Shear Box Tests gave bedding plane frictional angles of 35° and 25° for quartzite and moderately weathered dolomitic siltstone respectively.

Stereogram plots of quarry fracture data and spillway joint survey show stable batter conditions for all quarry faces. Falls of isolated boulders are expected to occur.

Monitoring of hillslope survey pegs shows no indication of soil-slip.

LITTLE PARA DAM
SLOPE STABILITY INVESTIGATION

INTRODUCTION

A project such as the construction of a dam involves the excavation of many batters in soil or rock and it was decided early on in the project to assist the stability investigation by calculating the residual friction angles for the two rock types found on the site.

The friction values were calculated by Coffey and Partners Pty. Ltd. Soil Consultants, using a HOEK SHEAR BOX. (Figures 51-54). The minimum residual friction angles for quartzite and moderately weathered dolomitic siltstone are 35° and 25° respectively, and these values have been used in the calculation of factors of safety for the quarry investigation discussed below.

The strata dip at about 30° eastwards across the site and any excavation in quartzite will be inherently stable; for dolomitic siltstone, particularly if highly weathered and saturated, any strike aligned excavation allowing down dip movement is likely to be unstable.

HILL SLOPE STABILITY

The soil adjacent to the dam is mainly a red-brown, calciomorphic soil up to 1-0 m thick resting upon weathered dolomitic siltstone.

Hillslope survey pegs were placed on the right bank upstream and downstream of the dam axis. Monitoring of these pegs over a two year period showed no evidence of movement.

Following construction of the dam the area on the right bank immediately upstream of the dam, involving an approximate soil volume of $45,000 \text{ m}^3$, was re-peged and monitored prior to filling the reservoir.

This is the only area where it is considered that soil slip into the reservoir resulting from saturation and subsequent reservoir draw down may occur. To date there has been no record of soil movement.

THE QUARRY

Short Term Fracture Survey

Prior to quarry excavation field data (stereogram Figure 55) indicated the potential instability of quartzite boulders during excavation of a fold in the quartzite stratum (Unit 9) which traverses the quarry. Using the data, a safe sequence for the early quarry excavation was therefore suggested:

- (a) Manual removal of large unstable blocks of quartzite;
- (b) Excavation of the folded part of the quartzite stratum;
- (c) Extraction of dolomitic siltstone starting from the western end and working eastward.

To guarantee the safety of the water treatment plant a second field data survey was carried out to assess the long term stability of the completed quarry batters.

Long Term Fracture Survey

Field data for the fracture analyses is shown as poles plotted on a stereogram (Figure 56). A summary of the field data for the eastern, central and western batters is shown in Figure 57 and the batters are referred to respectively as Regime I, II & III (Figure 58). Rock falls from the vertical batters of the central and eastern faces of the quarry can be expected with maximum block sizes of up to 1.0 m x 1.0 m x 0.50 m. Placement of a shallow ditch and cyclone fence at the foot of the batters has been advised, to prevent falling boulders from reaching the treatment works.

Small rock falls could also be expected from the western batter excavated at 40° and a low safety barrier is to be placed at the foot of the batter. Because bedding plane angle of friction is greater than bedding plane dip a planar failure of the batter into the excavation, although geometrically possible, is highly unlikely. Table 18 gives typical fracture data and their description and Figures 59, 60 and 61 show the stereographic calculation of the stability of rock masses formed by the intersection of fracture planes.

Mylonite occurs in three 200 mm - 400 mm wide shear zones 0.50 m apart found in the centre of the quarry at EL. 110 - EL. 123 within the quartzite stratum traversing the quarry. (Quarry profile summary Figure 62). Discontinuous joints, parallel to these shears, are clay coated and where they intersect open bedding planes form the main toppling feature.

Factors of safety for the fractures were calculated by assuming zero cohesion and zero water pressure across the two surfaces. Only the angle of friction was used. This value may be assumed on the basis of results of testing elsewhere of similar rocks or, as in this case, measured in the laboratory on rocks taken from the field (Hoek and Bray, 1974). An in-situ test, although possible was not carried out because of the high cost. Two coefficients (A and B) have been previously calculated by Hoek for most combinations of plane intersections. These values can be derived using his graphs and substituted in a simple equation with the friction angle. The result gives the factor of safety. Factors of safety above 2 indicate a stable condition able to withstand all but the most severe seismic activity.

TABLE 18 LITTLE PARA DAM QUARRY AND WATER TREATMENT WORKS, FRACTURE DESCRIPTION

LOCATION	TYPICAL MEASUREMENTS TAKEN	DESCRIPTION	NOTE
Eastern Regime I	090/90° 160/75°E Bedding 010/20°E	All joints in dolomite are planar curvilinear, uneven iron stained, tight to open upto 2 mm clay coating Average block sizes are in the range: 0.60 m x 0.50 m x 0.20 m to slabs: 1.40 m x 1.00 m x 0.30 m upto large blocks: 2.20 m x 2.10 m x 0.80 m. and rarely 2.70 m x 2.20 m x 1.70 m the last two sizes will require breakdown before use in the embankment.	
E.L.153-168 Quarry Centre Regime IIA	020/80°NW, 020/80°NW, 022/75°NW 080/80°N, 080/78°N, 080/80°N	Planar; uneven; clay coated upto 3 mm; discontinuous, against 090/68°N; iron stained. Similar orientation to 090/68°N but not planar uneven, semi continuous, fresh clean.	SEE NOTE A Fig. 62
E.L.137-153 Quarry Centre Regime IIB	040/75°NW, 042/80°NW, 040/85°NW 125/80°SW, 126/78°SW, 125/81°SW 070/55°N, 070/55°N, 068/55°N	Toppling fracture: planar, smooth-uneven continuous; clean, Tight-open (up to 4 mm) occur, 300 mm - 500 mm apart. Form wedges when intersect with above group; planar, discontinuous, open upto 10 mm showing clay coating, carbonate or quartz crystals. Planar, even, thinly clay coated, form very unstable wedges when intersect with above two groups	SEE NOTE B Fig. 62
Along the Quartzite Outcrop Central. Regime IIC.	010/85°W (dominant fracture) 085/85°N (i) 040/50°N fairly common. Shear (ii) 115/75°S pair? Form unstable wedges where intersect. 095/75°N Shear Zones Bedding 170°/22°E	Planar, uneven, ironstained, clay coated: 1-2 mm semi-continuous. (i) Planar, smooth, semi continuous, iron stained, slight clay development (ii) Irregular, uneven, ironstained. Mylonite and clay development Curvilinear, uneven, discontinuous closed - tight, rarely open 1-2 mm	SEE NOTE C Fig. 62
E.L.120-137 Central Regime IIC	005/88°N 000/vertical Bedding 000/12°E		
Western Regime III	085/75°N 000/80°W 170/80°E (rare) Bedding 005/3°E		
East of Centre	060/40°N 115/70°SW 040/82°N 020/90°	Common shallow angle joint spaced 0.30 m - 1.20 m apart planar, continuous, rarely coated. Important in reducing size of unit blocks. Common: 0.40 m x 0.25 m x 0.10 m to fist size typical large: 0.80 m x 0.50 m x 0.30 m rare large: 1.80 m x 0.80 m x 0.80 m.	
West of Centre	090/75°N 040/vertical; 040/80°SE, 038/85°NW Bedding 025/30°E	Planar - irregular; smooth-uneven, iron-stained, no clay coating, tight - open (4 mm); discontinuous. Curvilinear, even; continuous, ironstained no clay coating; tight to open (1mm - 3 mm) Unit block sizes. common: 0.60 m x 0.30 m x 0.15 m to fist size. Typical large: 0.90 m x 0.70 m x 0.70 m Rare large: 3.0 m x 2.0 m x 1.0 m	

TABLE 19

LITTLE PARA DAM QUARRY SITE - SLOPE STABILITY ANALYSIS

FACTORS OF SAFETY

Intersections ⁺	Dip	Dip Direction	Difference	ØA	Tan ØA	A Value	Comments	F.O.S.*
Plane A								
Plane B								
1+	20°	110°	65°	25°	0.47	> 5	Plane A, that is the plane designated 1 is the bedding plane. All other planes in the table are near vertical joints, and intersect to form thin elongate wedges. These are unstable except where they sit upon the bedding plane. In this case removal by crow bar is necessary before the batter is safe enough to work or build near. The fracture designated as 3 has a very variable strike (065-100). It is associated with poorly developed shear planes and provides potential toppling failures in the centre of the central batter between EL. 120 and EL. 130 (See Figure 62, Note C).	> 3.75
2	85°	130°	25°	35°	0.7	2.0		
1	20°	110°	55°	25°	0.47	3.1		
3	75°	175°	65°	35°	0.7	0.4		
1	20°	110°	70°	25°	0.47	> 5		
4	90°	090°	20°	35°	0.47	2.5		
1	20°	110°	65°	25°	0.47	2.7		
5	85°	040°	70°	35°	0.7	0.4		
2a	80°	130°	0°	35°	0.7	> 5		
2b	80°	310°	180°	35°	0.7	> 5		
2	75°	130°	10°	35°	0.7	<0.3		
5	85°	040°	90°	35°	0.7	<0.1		
3	75°	175°	10°	35°	0.7	0.6		
5	85°	040°	135°	35°	0.7	0.5		
5	85°	040°	5°	35°	0.7	0.2		
4	90°	090°	50°	25°	0.47	0.2		

Plane A taken as least steep plane. *F.O.S. = $A \tan \phi_A + B \tan \phi_B$. + See Figure 3 for identification and location of planes.

TABLE 19 Slope Stability Analysis Factors of Safety

Low factors of safety shown in Table 19 indicate only the instability of small thin slabs of rock (0.70 m x 0.30 m x 0.30 m) and do not indicate the presence of an unstable rock mass.

THE SPILLWAY

Stereographic plotting of rock defects, examination of drill core and a cross-sectional glass model were used to determine excavation conditions and batter angles in the spillway.

Dip and strike measurements of fractures were taken on outcrops of the dolomitic siltstone and quartzite, and their poles plotted on a stereogram (Figure 63).

It was established early in the fracture survey that the strike and dip readings for the joints and bedding planes were very similar for the two rock types but that the joints differed in intensity, frequency and condition. The thickness of the parting between bedding planes and between joints are greater in the quartzite strata; the dolomitic siltstone being more fissile. Maximum block sizes for the quartzite and dolomitic siltstone are shown in Table 20 below.

TABLE 20
MAXIMUM BLOCK SIZES

Rock Type	Geological Unit (Ref. Fig. 5)	Vol. (m ³)	Approx. Weight (Tonnes)
Dolomitic siltstone	17	0.2	½
Quartzite	16	2.0	5
Dolomitic Siltstone	15	0.2	½
Quartzite	14	2.5	5½
Dolomitic Siltstone	13	0.2	½
Quartzite	12	10.0	25

Bedding

The bedding and cleavage in the dolomitic siltstone are sub-parallel to one another. Measurements taken along the spillway alignment show strikes and dips ranging from $005/29^{\circ}$ eastwards to $015/35^{\circ}$ eastwards, with rare exceptions dipping up to 48° eastwards. The mean is taken as $012/33^{\circ}\text{E}$ and is shown as Group 1 in the table below and in Figure 62.

Group	Typical Strike	Dip
(Bedding) 1.	012°	33°E
(Joint) 2.	156°	76°W
(Joint) 3.	078°	83°W
(Joint) 4.	215°	77°W

HOEK SHEAR BOX
(Summary Sheet)

client: S.A. DEPARTMENT OF MINES
project: LITTLE PARA DAM
location:

office: ADELAIDE
date: 6/11/74
by: RAR & GS
checked:

sample identification: UNIT 10, QUARTZITE. NORTH OF CENTRE. SAMPLE 1

SUBSTANCE DESCRIPTION: QUARTZITE, fine to medium grained, slightly weathered, strong.

DEFECTS: One planar defect with interlocking asperities. 1-2 mm.

PHYSICAL PROPERTIES

Weight = 670.2 gms
Volume = 262 ccs
Bulk Density = 2.56 t/m³
Moisture Content = -
Shear Area = 6.8 x 10⁻³ m²

TEST PROCEDURE: Normal load of 1.5 mPa applied. Shear applied to displace 7.0 mm, load reversed to bring back to starting position and shear continued until approx. 7.0 mm displacement in direction opposite to initial displacement. Procedure repeated with loads of 0.9 mPa and 0.45 mPa.

STRAIN RATE	mm/min	Normal Load	Normal Stress
(1)	10	kN	1.5 mPa
(2)	6		0.9
(3)	3		0.45

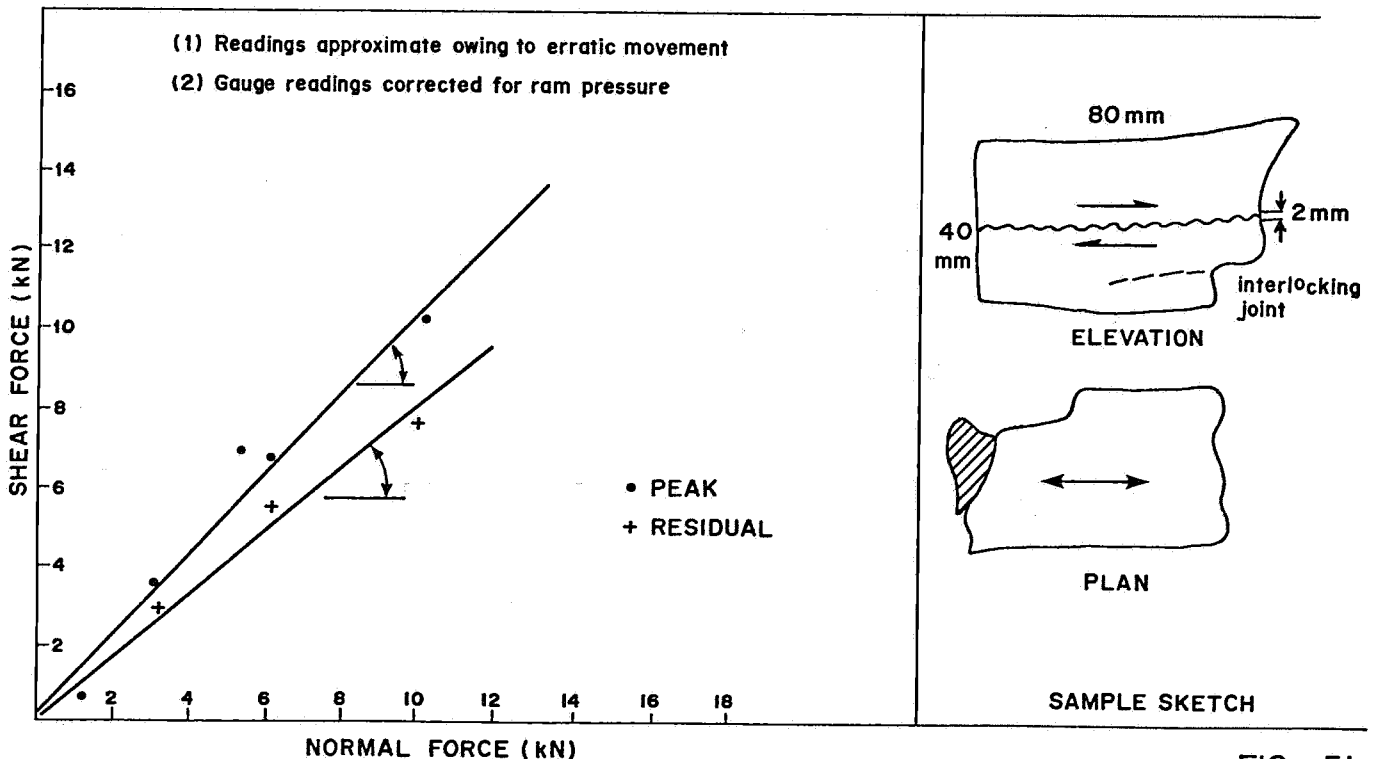
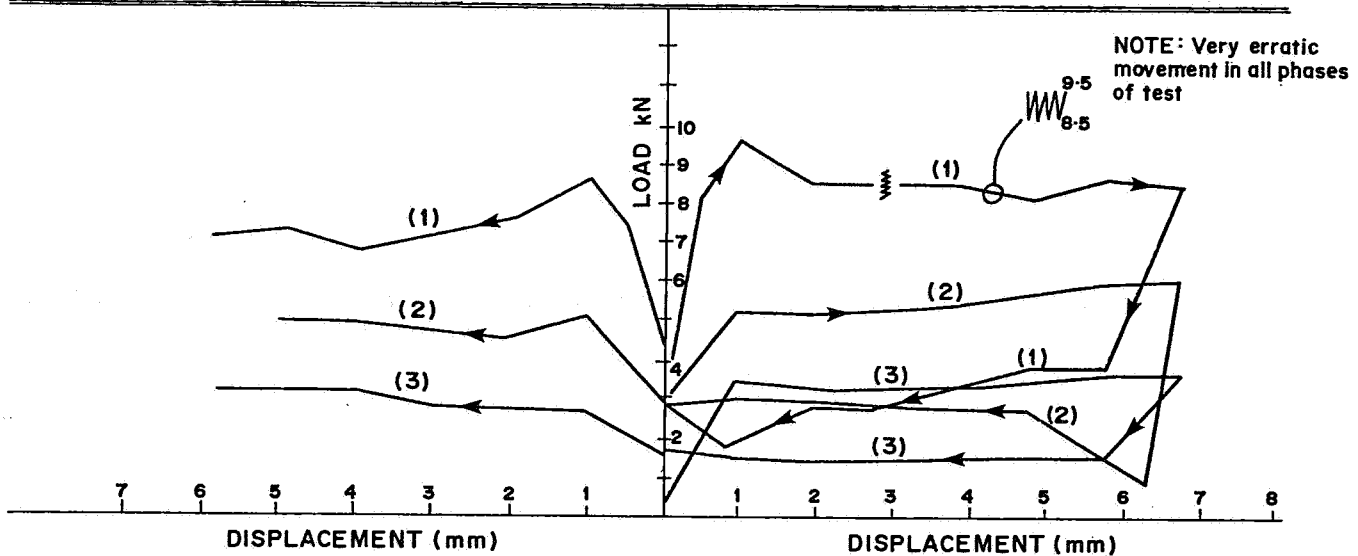


FIG. 51

HOEK SHEAR BOX
(Summary Sheet)

client: S.A. DEPARTMENT OF MINES
project: LITTLE PARA DAM
location:
sample identification: No. 2

office: ADELAIDE
date: 12/11/74
by: RAR & GS
checked:

SUBSTANCE DESCRIPTION: Dolomite siltstone, grey thinly laminated (1 mm bedding) finely micaceous

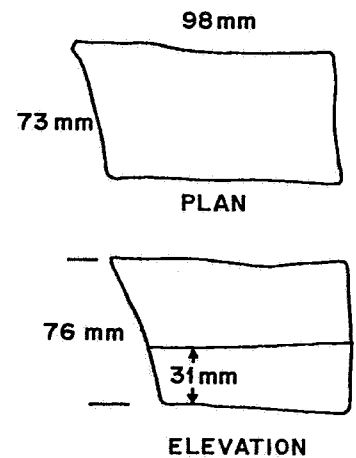
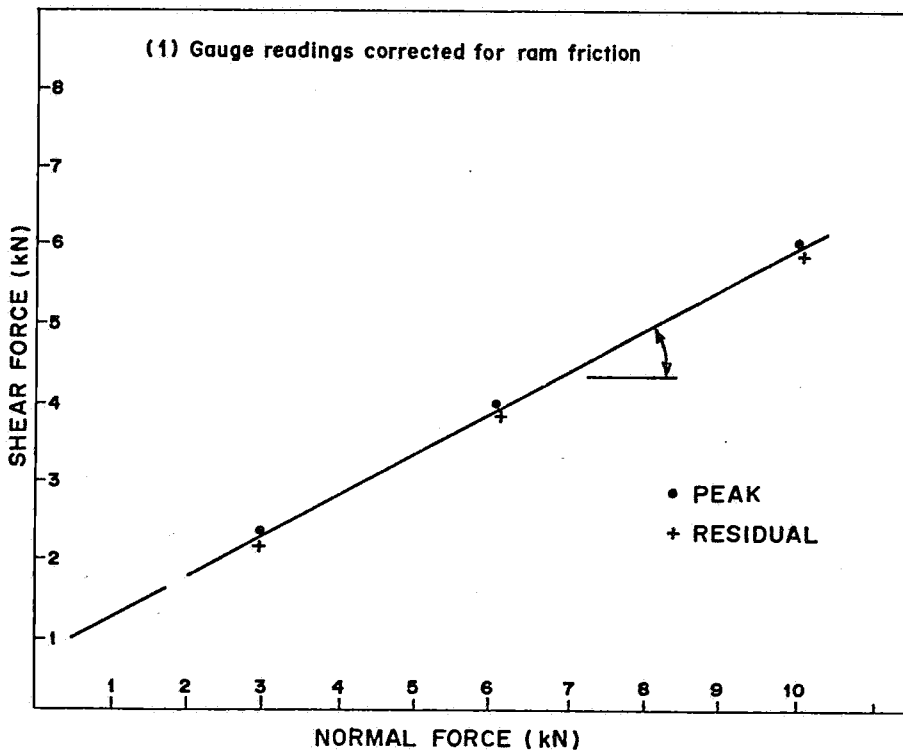
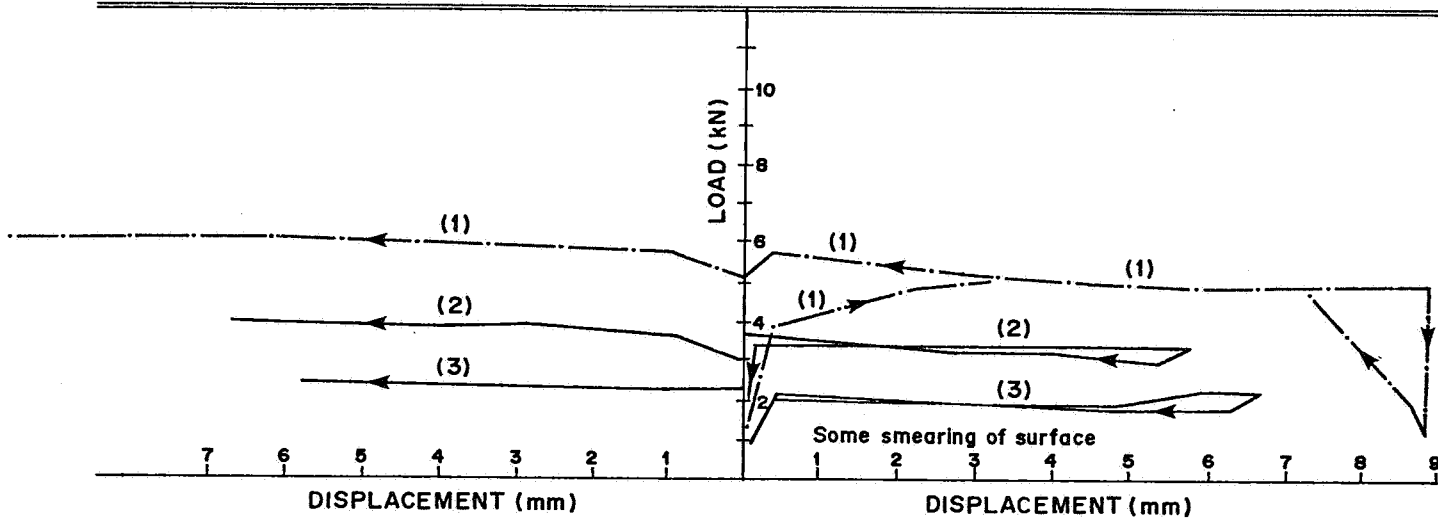
DEFECTS: Planar joint along bedding surface undulations ± 1-2 mm. Sample interlocks but not tightly.

PHYSICAL PROPERTIES

Weight = 1065.1 gms
Volume = 426 ccs
Bulk Density = 2.50 t/m³
Moisture Content = - %
Shear Area = 5.3 x 10⁻³ m²

TEST PROCEDURE: Normal load of 1.9 mPa applied. Shear applied to displace approx. 7.0 mm, load reversed to bring back to starting position and shear continued until approx. 7.0 mm displacement in direction opposite to initial displacement. Procedure repeated with loads of 1.1 mPa and 0.57 mPa.

STRAIN RATE	mm/min	Normal Load	Normal Stress
Stage (1)	10	kN	1.9 mPa
(2)	6		1.1
(3)	3		0.57



SAMPLE SKETCH

HOEK SHEAR BOX
(Summary Sheet)

client: S.A. DEPARTMENT OF MINES
project: LITTLE PARA DAM
location:
sample identification: No. 3

office: ADELAIDE
date: 11/11/74
by: RAR & GS
checked:

SUBSTANCE DESCRIPTION: QUARTZITE - UNIT 10
grey brown, strong-very strong, fresh to
slightly weathered.

DEFECTS: UNDULATING SURFACE (UNDULATIONS \pm
8 mm) though microsurface relatively smooth
with fine lime coating.

PHYSICAL PROPERTIES

Weight = 1037 gms
Volume = 408 ccs
Bulk Density = 2.54 t/m^3
Moisture Content = -
Shear Area = $6.1 \times 10^{-3} \text{ m}^2$

TEST PROCEDURES: Normal load of 1.6 mPa
applied. Shear applied to displace 7.0 mm
and then load reversed to bring back to
zero displacement. Procedure repeated with
normal loads of 1.0 and 0.5 mPa.

STRAIN RATE		mm/min.
Stage	Normal Load	Normal Stress
(1)	10 kN	1.6 mPa
(2)	6	1.0
(3)	3	0.5

NOTE: Minor grinding of asperities and flaking
of corners

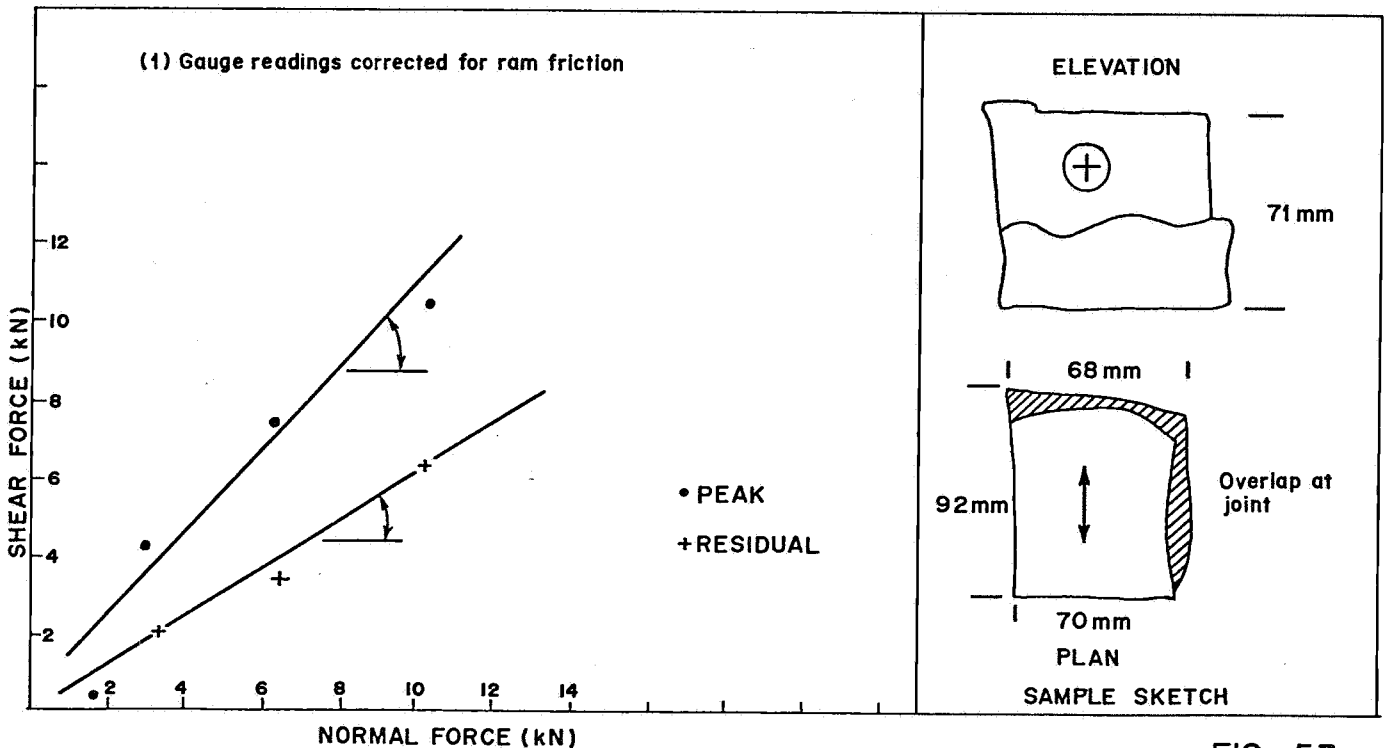
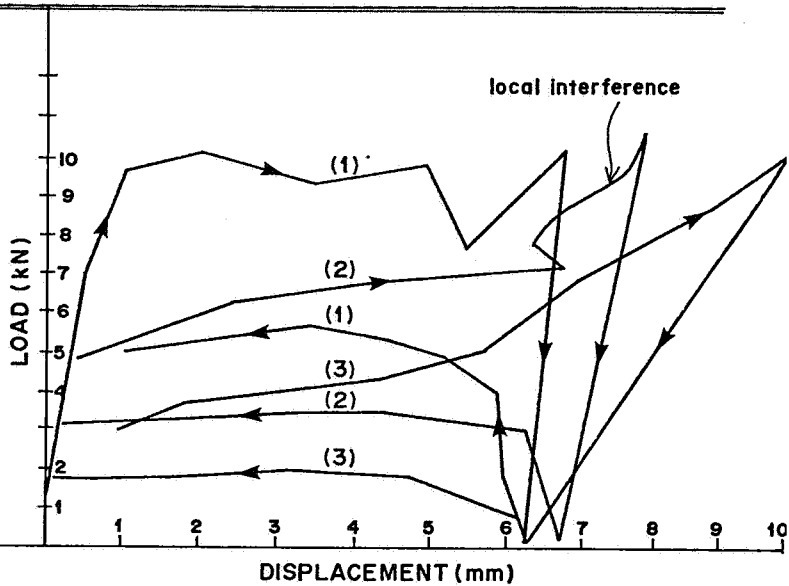


FIG. 53

HOEK SHEAR BOX
(Summary Sheet)

client: S.A. DEPARTMENT OF MINES
project: LITTLE PARA DAM
location:
sample identification: No. 4

office: ADELAIDE
date: 12/11/74
by:
checked:

SUBSTANCE DESCRIPTION: Dolomite siltstone
thinly laminated highly weathered, weak.

PHYSICAL PROPERTIES

Weight = 1232 gms
Volume = 710 ccs
Bulk Density = 1.74 t/m³
Moisture Content: 27.4%
Shear Area = 7.8 x 10⁻³ m²

DEFECTS:

TEST PROCEDURE: Normal load 1.3 mPa applied. Shear applied to displace 4.0 mm. Sample tilted and caused interference between plaster sample mountings. Test discontinued.

STRAIN RATE	mm/min
Stage Normal Load	Normal Stress
(1)	10 kN 1.3 mPa
(2)	6
(3)	3

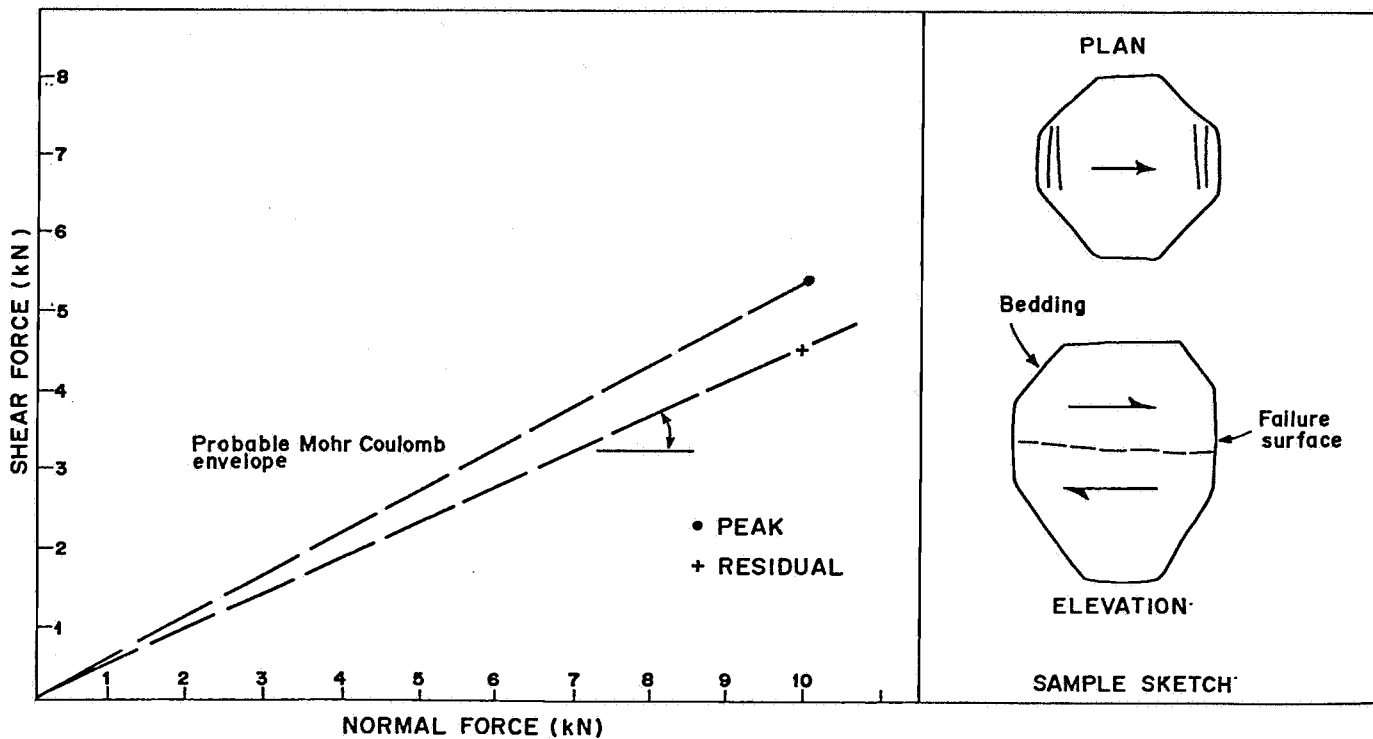
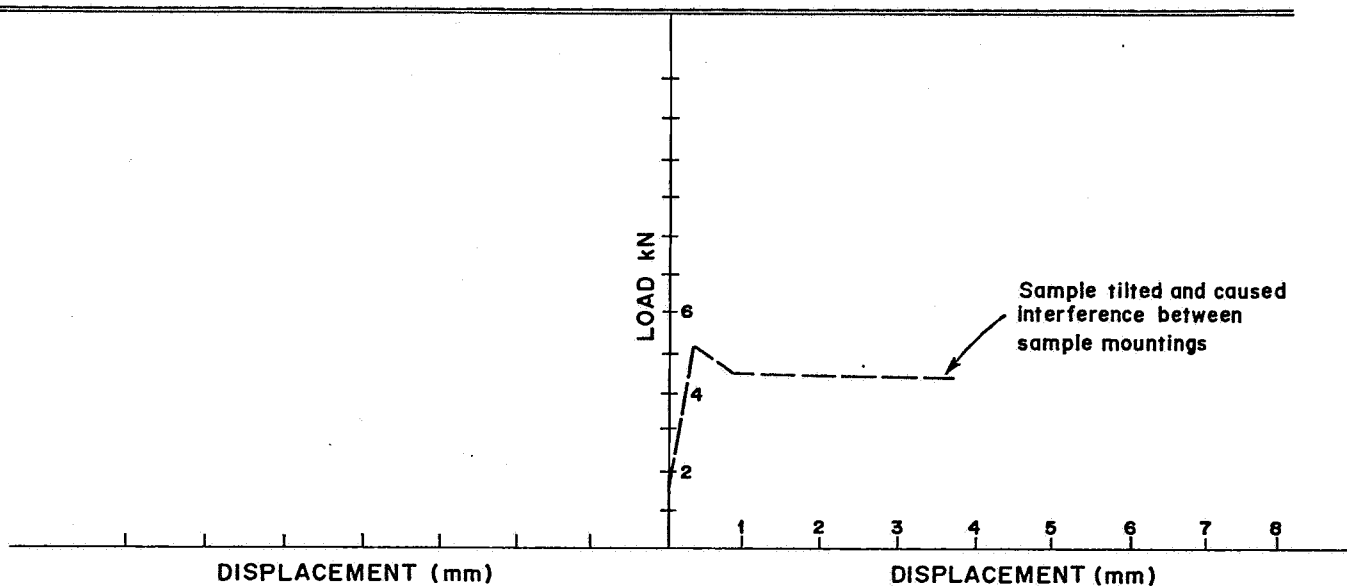
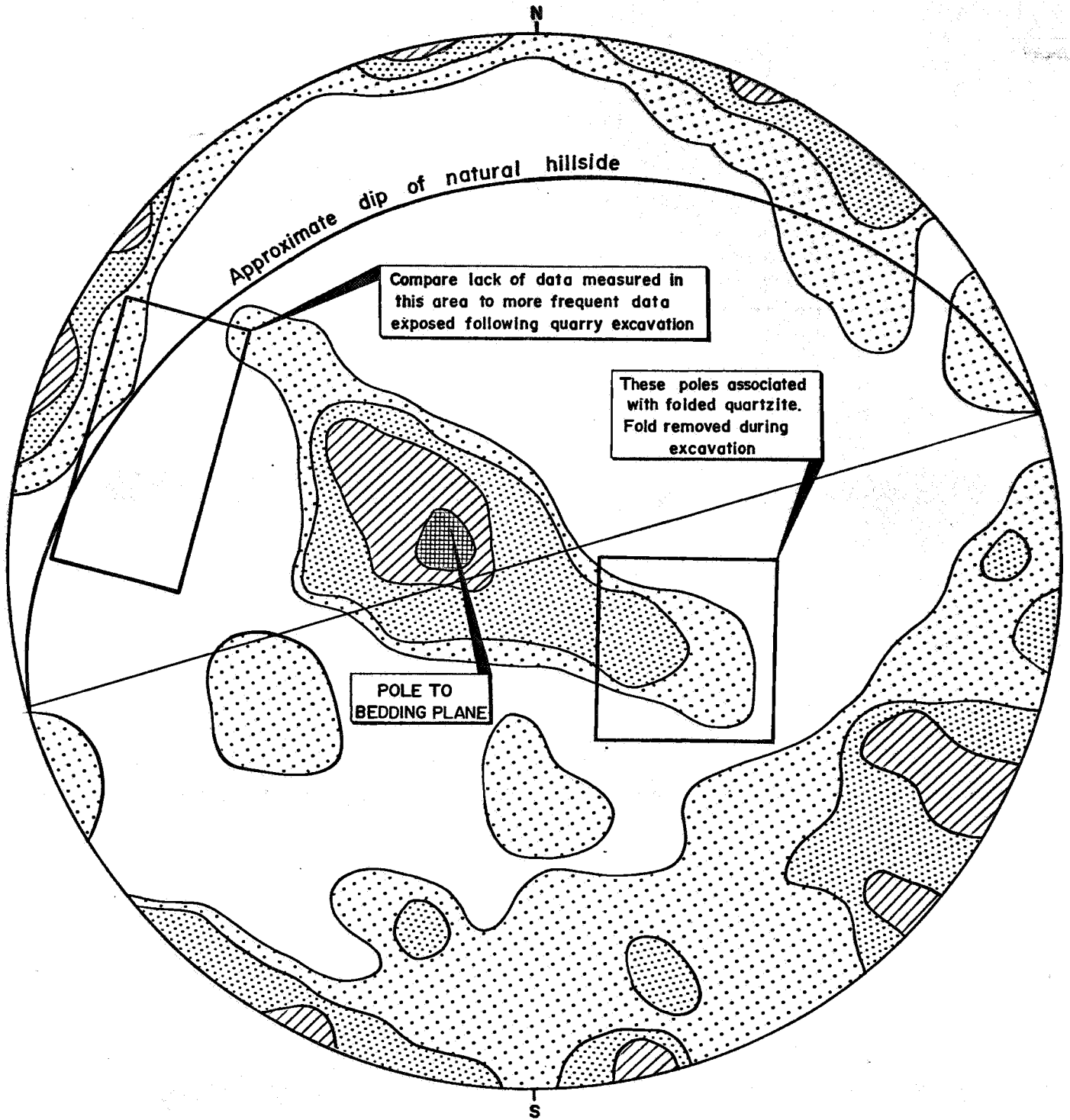


FIG. 54



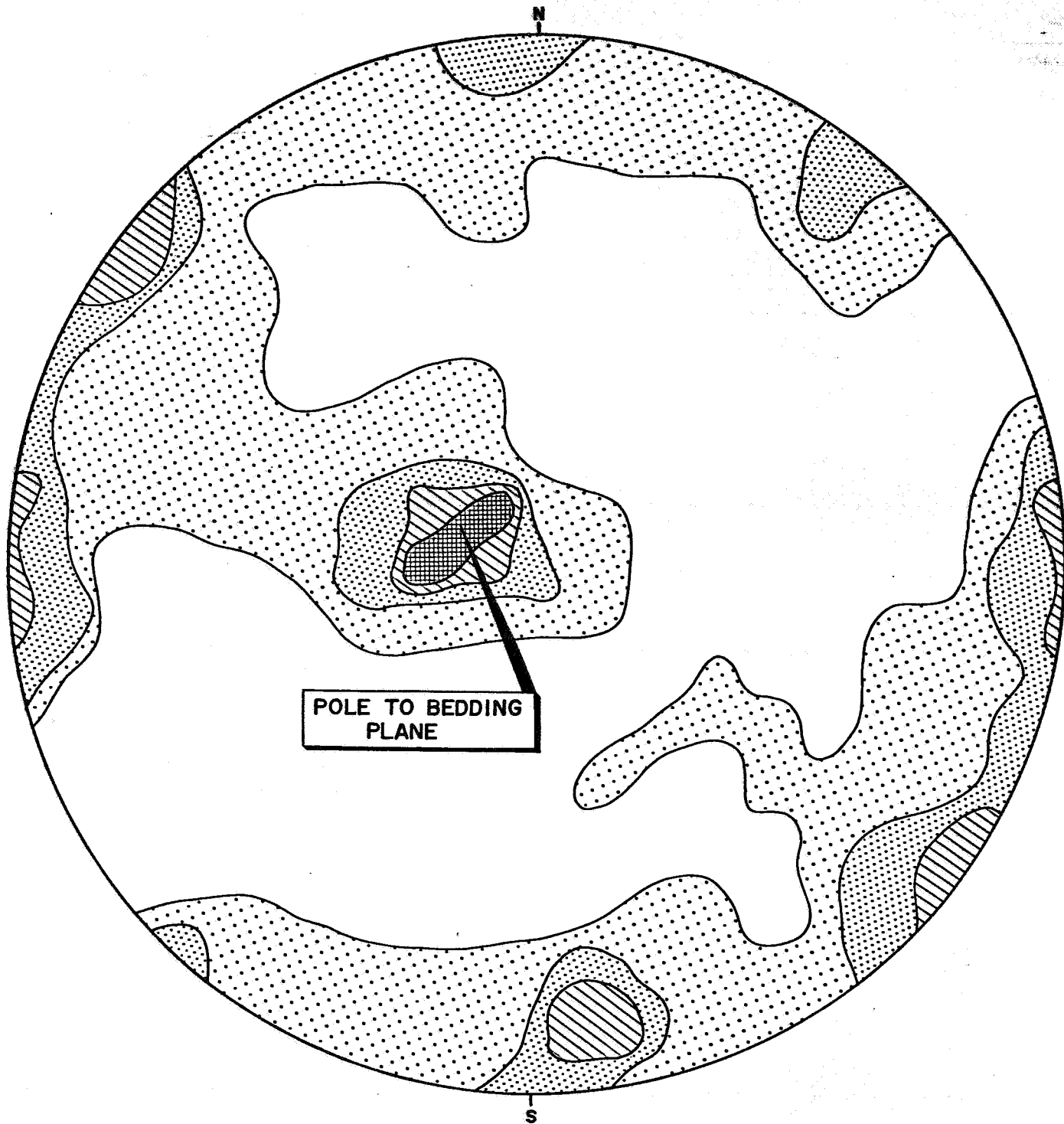
TOTAL POLES 80

4-8	(5-10%)	
8-16	(10-20%)	
16-20	(20-25%)	
>20	(>25%)	


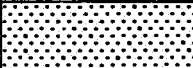

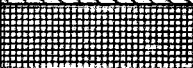
FIG. 55

TAKEN FROM NATURAL OUTCROP PRIOR TO QUARRY EXCAVATION 1975

ENGINEERING SERVICES	DEPARTMENT OF MINES - SOUTH AUSTRALIA	SCALE: —
COMPILED: J.C. Beal	LITTLE PARA DAM - WATER TREATMENT WORKS	DATE: 30-6-77
DRN: N.S. CKD.	SLOPE STABILITY ANALYSIS	PLAN NUMBER:
	STEREOGRAPHIC PROJECTION OF CONTOURS ON POLES OF JOINTS AND BEDDING PLANES	S12763



TOTAL POLES 140

1-4	(3%)	
5-9	(6.5%)	
10-14	(10%)	
>14	(>10%)	

DATA TAKEN AFTER QUARRY EXCAVATION

FIG. 56

ENGINEERING SERVICES

DEPARTMENT OF MINES - SOUTH AUSTRALIA

SCALE - —

COMPILED: J.C. Beal

LITTLE PARA DAM - WATER TREATMENT WORKS
SLOPE STABILITY ANALYSIS

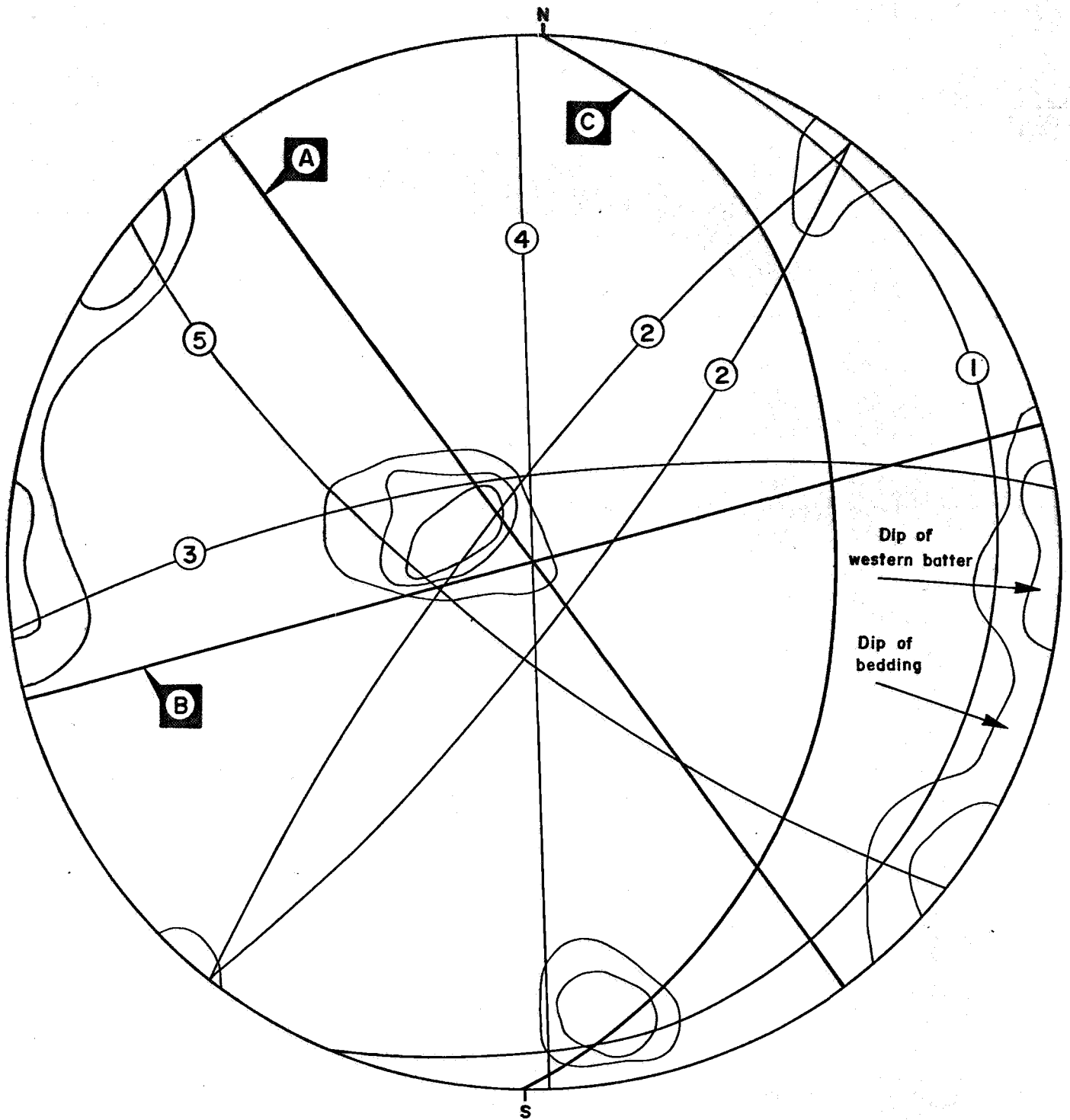
DATE: 30-6-77

DRN: N.S. CKD.

STEREOGRAPHIC PROJECTION OF CONTOURS
ON POLES OF JOINTS AND BEDDING PLANES

PLAN NUMBER:

S12762



- ① Bedding plane.
- ② Near vertical joints in quartzite and dolomite.
- ③ Steep joints mainly found in quartzite and associated with shear zone.
- ④ Vertical joints mainly found in dolomite.
- ⑤ Near vertical joint mainly found in quartzite.

- A** EASTERN BATTERS VERTICAL
- B** CENTRAL BATTERS VERTICAL
- C** WESTERN BATTERS 40°-45°

SUMMARY OF MAIN FRACTURES

FIG. 57

ENGINEERING SERVICES	DEPARTMENT OF MINES - SOUTH AUSTRALIA	SCALE. —
COMPILED: J.C. Beal	LITTLE PARA DAM - WATER TREATMENT WORKS SLOPE STABILITY ANALYSIS	DATE: 30-6-77
DRN: N.S. CKD.	STEREOGRAPHIC REPRESENTATION OF RELATIONSHIP BETWEEN FRACTURE POLES, FRACTURE PLANES AND QUARRY BATTER PLANES	PLAN NUMBER: S 12761

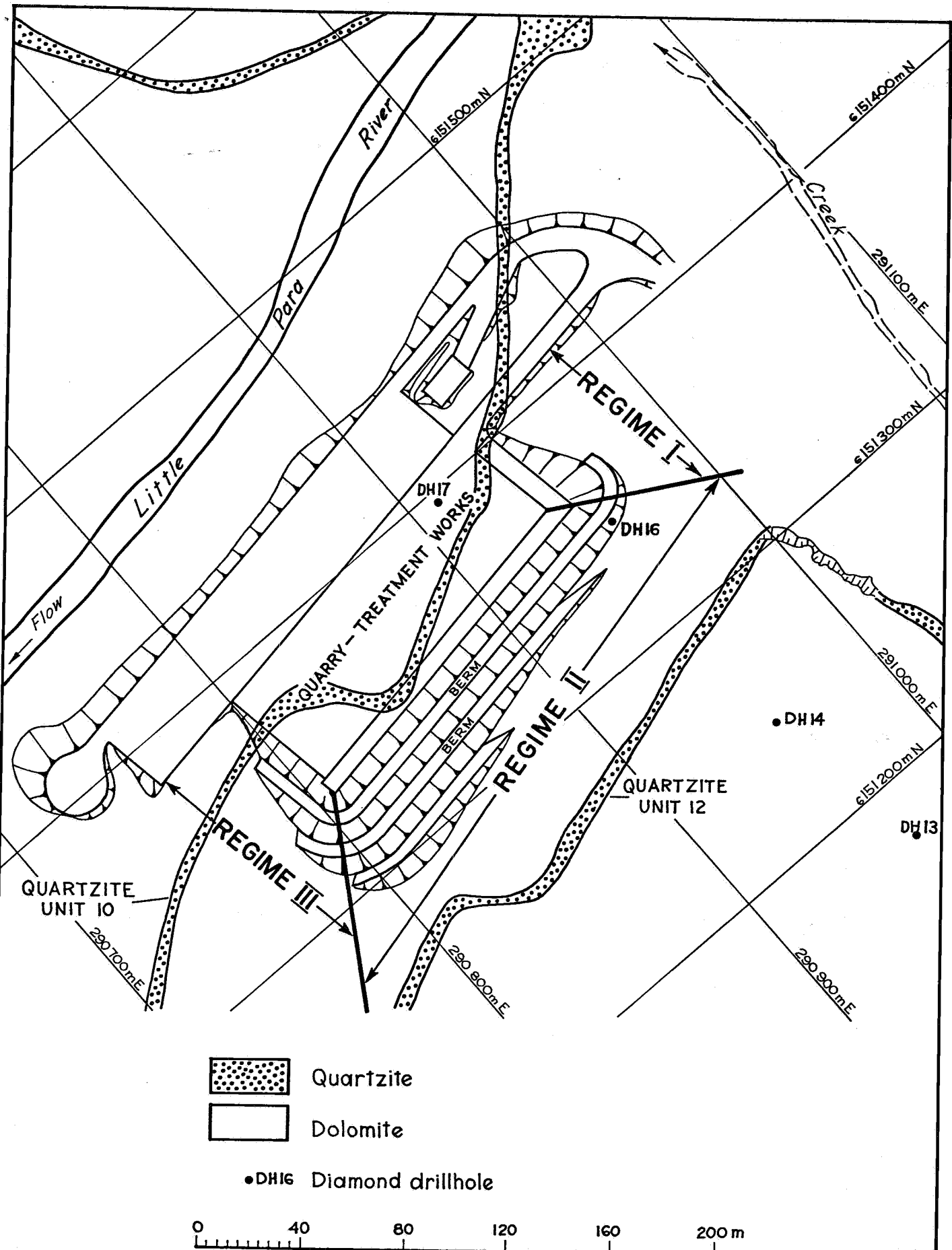
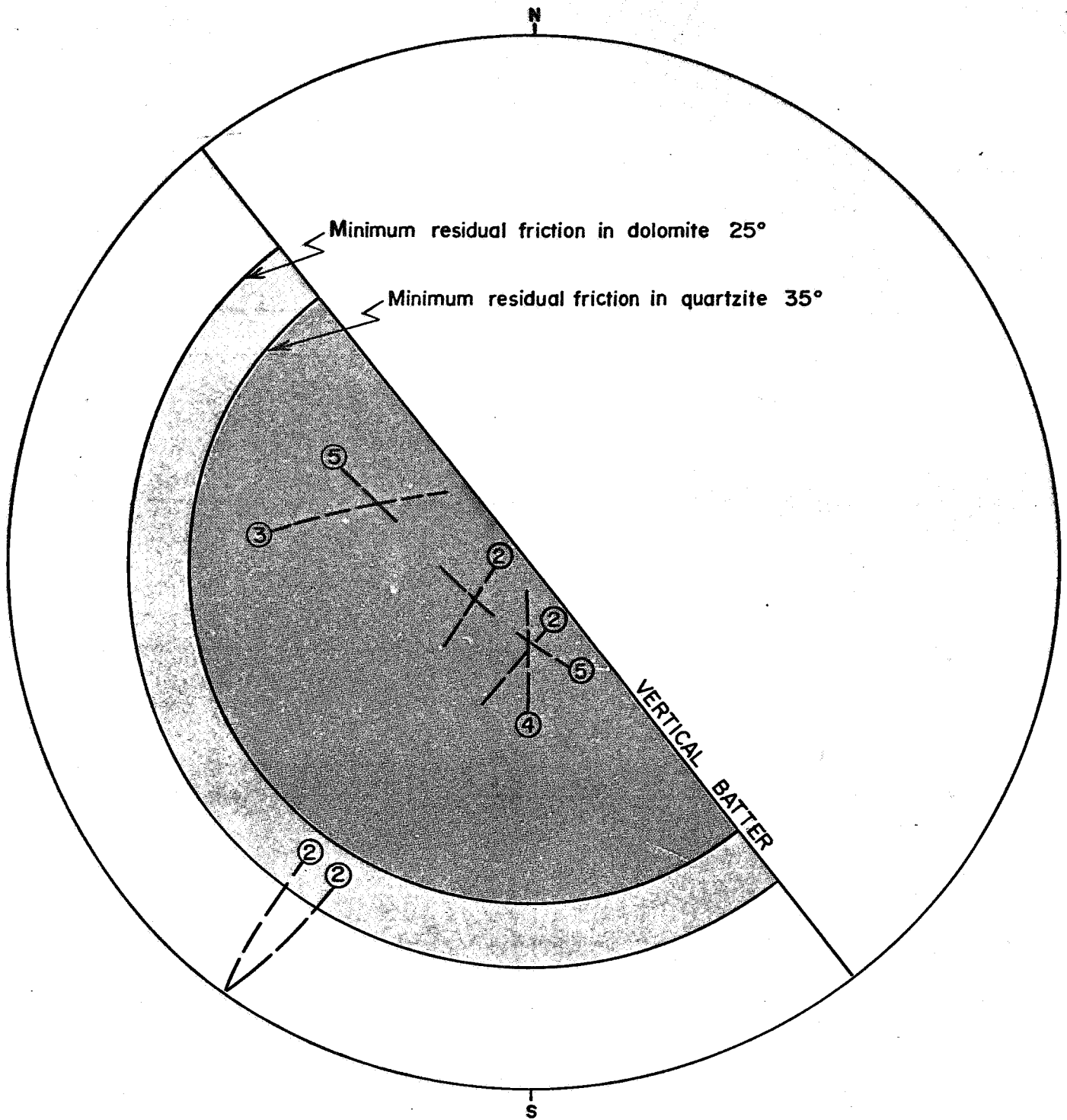


FIG. 58

ENGINEERING SERVICES	DEPARTMENT OF MINES - SOUTH AUSTRALIA	SCALE: 1:2000
COMPILED: J.C. Beal	LITTLE PARA DAM - WATER TREATMENT WORKS SLOPE STABILITY ANALYSIS REGIME LOCATIONS	DATE: 28.6.77
DRN: A.F. CKD.		PLAN NUMBER: S 12760

1126



NO LARGE SCALE INSTABILITY

FAILURE MODE	FRACTURE INTERSECTIONS
Small wedge-blocks	5 and 3 ; 2 and 5 ; 5 and 4

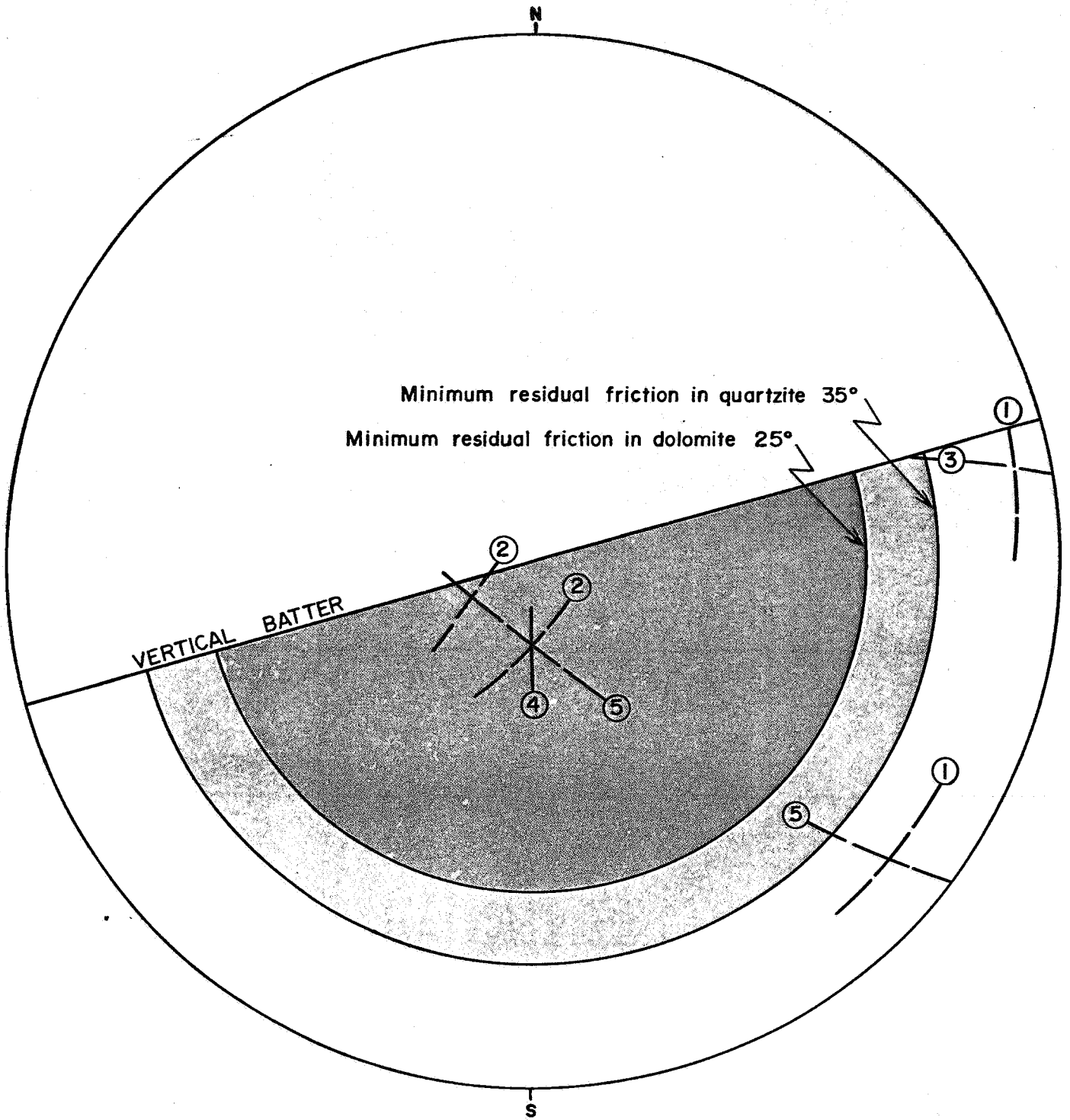
Intersections falling within shaded areas form potentially unstable wedges.

(from HOEK AND BRAY 1974)

FIG. 59

ENGINEERING SERVICES	DEPARTMENT OF MINES - SOUTH AUSTRALIA	SCALE: —
COMPILED: J.C. Beal	LITTLE PARA DAM - WATER TREATMENT WORKS SLOPE STABILITY ANALYSIS	DATE: 30-6-77
DRN: N.S. CKD.	STEREOGRAPHIC PROJECTION SHOWING INTERSECTION OF JOINTS - EASTERN QUARRY BATTER	PLAN NUMBER: S 12764

1126



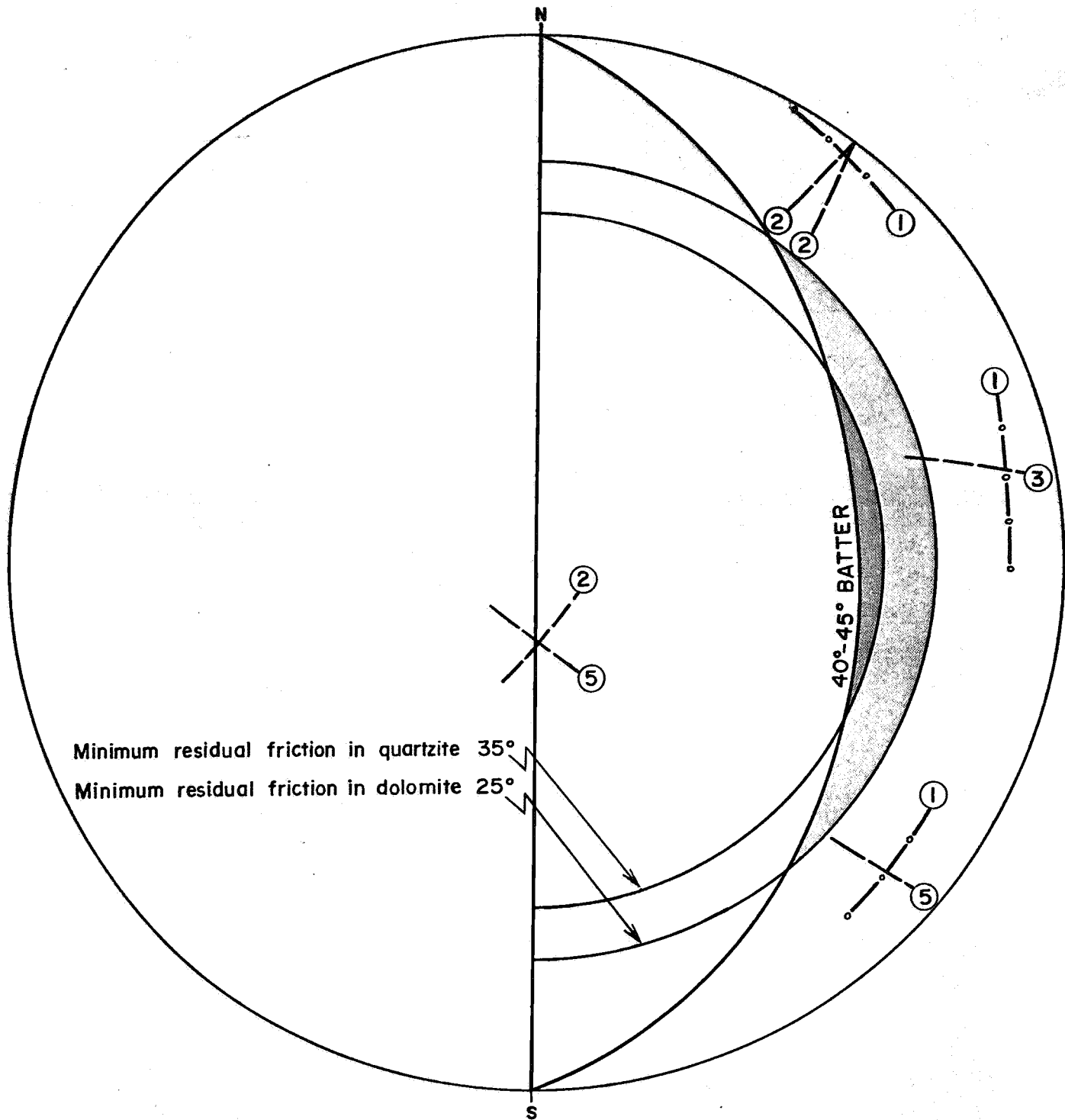
FAILURE MODE	FRACTURE INTERSECTIONS
Wedge failure of small blocks	2 and 5 ; 4 and 5

Intersections falling within shaded areas forms potentially unstable wedges.

(from HOEK AND BRAY 1974)

FIG. 60

ENGINEERING SERVICES	DEPARTMENT OF MINES - SOUTH AUSTRALIA	SCALE: —
COMPILED: J.C. Beal	LITTLE PARA DAM - WATER TREATMENT WORKS SLOPE STABILITY ANALYSIS	DATE: 30-6-77
DRN: N.S. CKD.	STEREOGRAPHIC PROJECTION OF THE INTERSECTION OF JOINTS AND BEDDING PLANE - CENTRAL QUARRY BATTER	PLAN NUMBER: S 12765



All intersections form stable blocks.

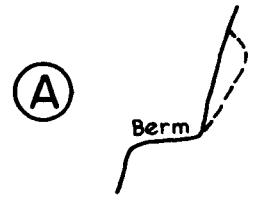
Intersections falling within shaded areas form potentially unstable wedges.

(from HOEK AND BRAY 1974)

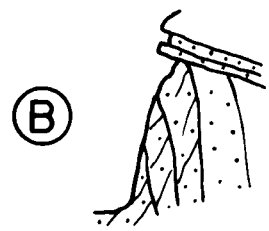
FIG. 61

ENGINEERING SERVICES	DEPARTMENT OF MINES - SOUTH AUSTRALIA	SCALE. —
COMPILED: J.C. Beal	LITTLE PARA DAM - WATER TREATMENT WORKS SLOPE STABILITY ANALYSIS	DATE: 30-6-77
DRN: N.S. CKD	STEREOGRAPHIC PROJECTION OF THE INTERSECTION OF JOINTS AND BEDDING PLANE - WESTERN QUARRY BATTER	PLAN NUMBER:
		S 12766

1126



Failure plane on joint (090°/68°N) and overhanging bedding plane 3.0m high ; 6.0m long ; 0.4 m deep
 Joint planar ; continuous ; iron stained ; some clay coating up to 3mm.



Dolomite slabs overhanging.
 Flaggy quartzite slabs overhanging.
 Quartzite. Continuous, clean planar fractures form toppling feature.



3 shear zones (095°/75°N) 0.50m apart.
 Mylonite /clay development up to 400mm form a potential toppling feature.

Note: 090°/68°N indicates that the plane strikes at 090° (E-W in this case) and dips towards the north at 68° from the horizontal.

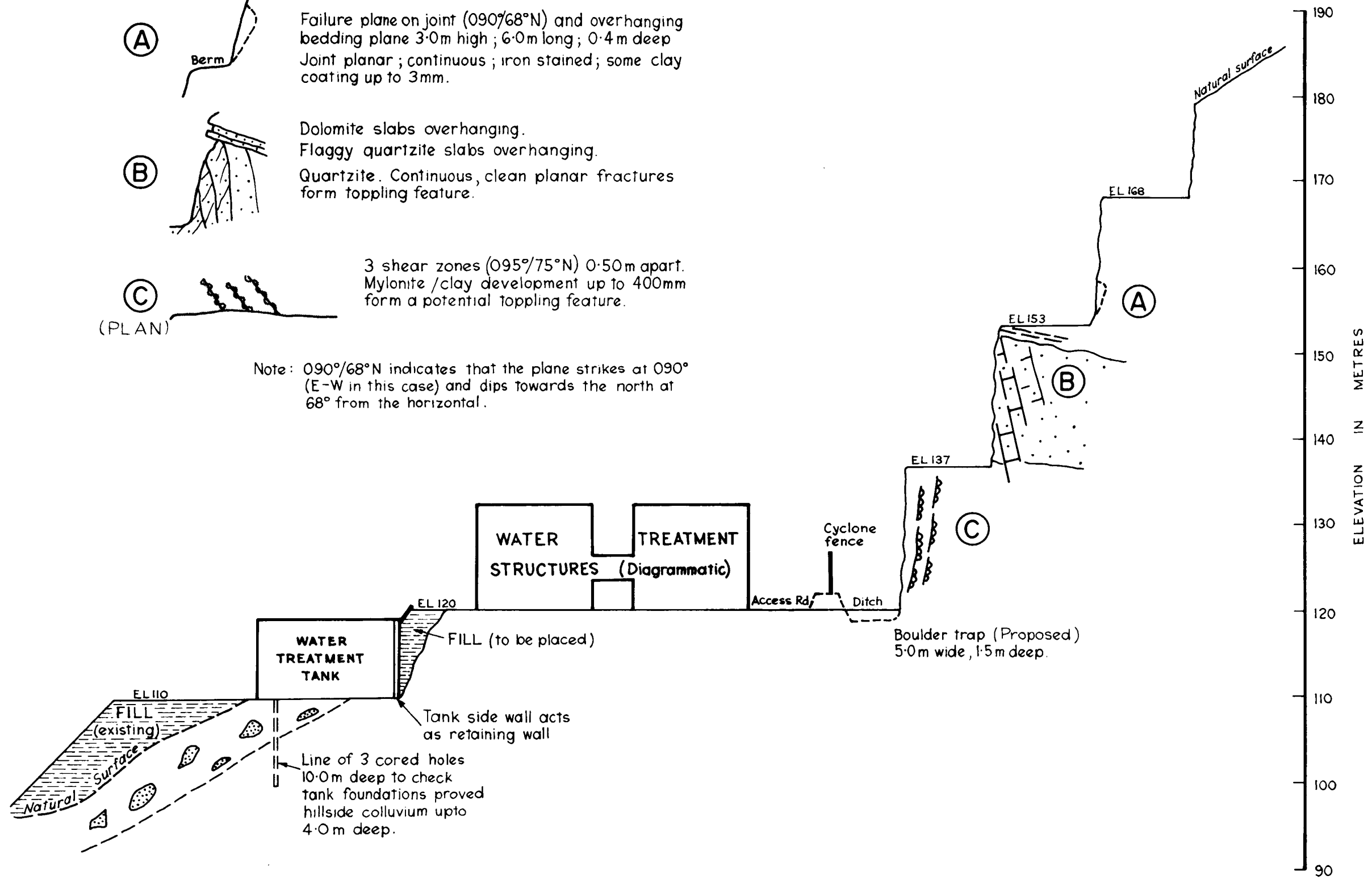
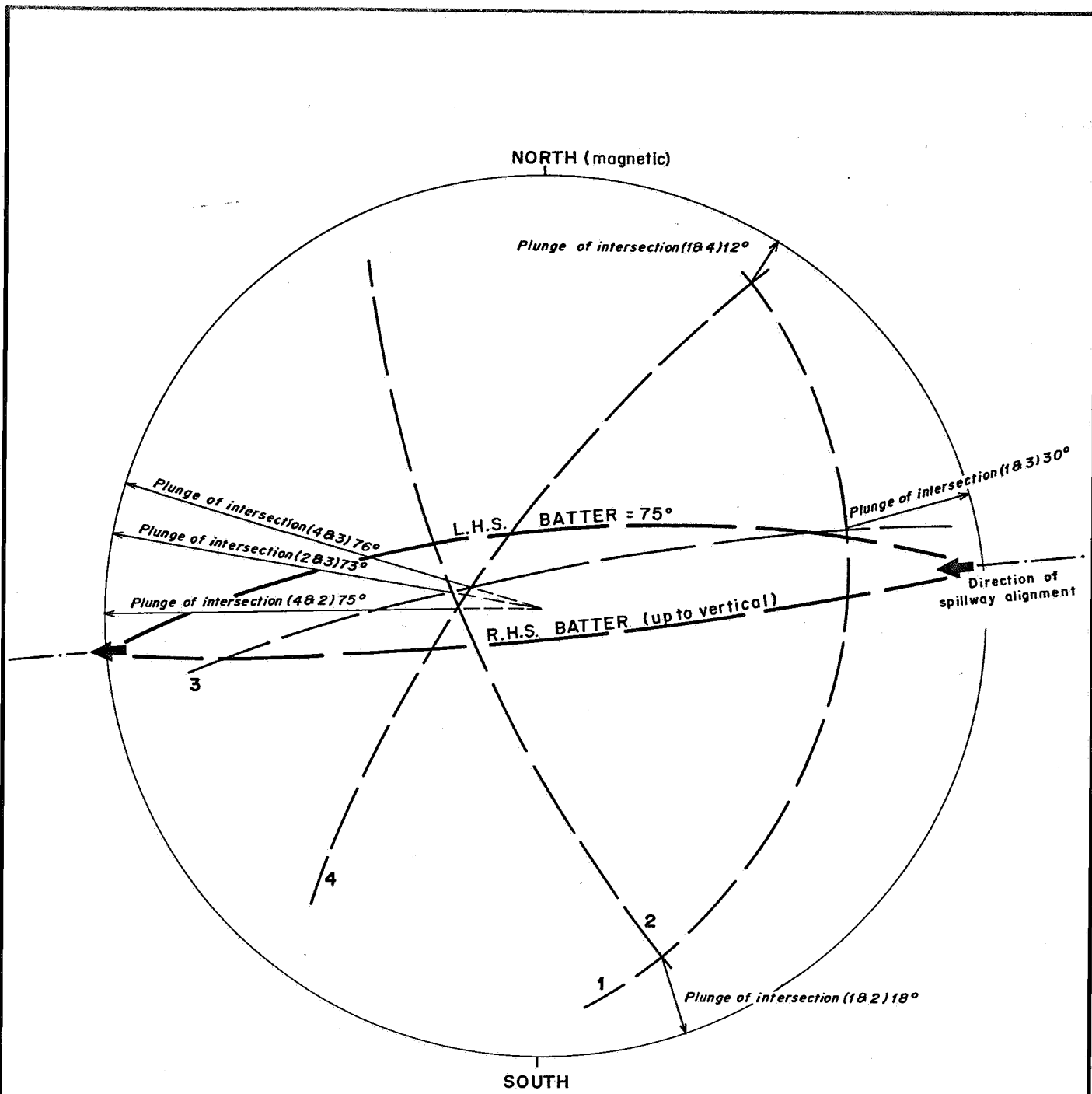


FIG. 62

ENGINEERING SERVICES	DEPARTMENT OF MINES - SOUTH AUSTRALIA	SCALE : 1:500
COMPILED : J.C. Beal	LITTLE PARA DAM	DATE : 30.6.77
DRN : A.F. CKD.	MAIN QUARRY AND WATER TREATMENT WORKS	PLAN NUMBER :
	SLOPE STABILITY ASSESMENT - QUARRY PROFILE	77-595



FEATURE	STRIKE	DIP
1 Bedding	012°	33°E
2 Joint	156°	76°W
3 Joint	078°	83°N
4 Joint	215°	77°W

Fig. 63

		DEPARTMENT OF MINES AND ENERGY SOUTH AUSTRALIA		SCALE: Diagrammatic	
COMPILED J.C.Beal.		LITTLE PARA DAM		DATE May 1978	
DRN.G.J.T.	CKD			PLAN NUMBER	
		SPILLWAY FRACTURE SURVEY		S13408	

1126

APPENDIX 4

MATERIAL TESTING

SUMMARY OF TABLES, FIGURES & REPORTS

SUMMARY OF MATERIAL TESTS

LIST OF CONTENTS

TABLES

- Table 21: Petrological Description of Rock Types.
- Table 22: Summary of Physical Properties.
- Table 23: Relationship between Drilling rate and rock strength.
- Table 24: Rockfill and Concrete Aggregate Laboratory Tests.
- Table 25: Summary of some physical tests on three samples taken from Parapet wall trench.
- Table 26: Summary of Ring Density Test results.

FIGURES

- Figure 64: Mechanical Analysis of Soil Road Fill.
- Figure 65: Grading Curves for weathered dolomitic siltstone samples from Inspection trench.
- Figure 66: Mechanical Analysis of weathered dolomitic siltstone from Parapet Wall trench and left bank grout cap.
- Figure 67: Ring Density Test and specification of Zone 1 rockfill.

REPORTS

- Report by the Australian Mineral Development Laboratories on the Suitability of 5 samples for concrete aggregate.
- Soils Laboratory Report on Permeability Tests on 3 samples of weathered dolomitic siltstone.

TABLE 21

Petrological Description of Rock Types

REPT. NO.	SAMPLE NO.	ROCK TYPE	MINERAL CONTENT %						
			Quartz	Dolomite	Carbonate	Phyllo- silicates	FELDSPAR Plag. Ortho.	Opaques	
MP2442/73	P853/72	QUARTZITE (1)	55-65			Tr (sericite/ chlorite)	5-10	20-30	Tr
	P854/72	DOLOMITE (2)	3-6	90-95					2-4
	P855/72	DOLOMITE (3) (impure)	2-4	90-95					2-4
MP5072/73	P307-310/73 T.S.30620-3	QUARTZITE (4) (feldspathic)	80-90		0-2		1-5	7-10	1

- (1) This rock is thought to be a well sorted sediment, an arkose sandstone that has been metamorphosed.
- (2) This is a fine grained impure dolomite which has been strongly foliated and now has a schistose texture.
- (3) As above (2) but lacking the schistose texture.
- (4) Recrystallised arkose sandstone firmly welded by fracturing and crystal growth; feldspar grains have fractured but have been sealed by quartz. A high confined compressive strength for the rock is expected.

TABLE 21 Petrological Description of Rock Types

TABLE 22
SUMMARY OF PHYSICAL PROPERTIES

SUBSTANCE	TEST	RESULTS	COMMENTS
QUARTZITE	YOUNGS MODULUS	5.3 x 10 ⁴ - 8.7 MPa	Tested wet and dry.
"	SPECIFIC GRAVITY	2.593 - 2.650	Gross Apparent: (SSD Basis).
DOLOMITE	WATER ABSORPTION	1.2%	*range of values from different samples tested in different laboratories.
QUARTZITE	" "	*0.41% - 0.60%	
"	UNIAXIAL COMPRESSIVE STRENGTH	85.5 - 296 MPa	Tested wet and dry. Samples from 8.00-16.00 m depth. Axial failures.
"	POINT LOAD TESTS	DIAMETRAL: 36.2-44.8 MPa AXIAL : 15.5-39.6 MPa	Using N.M.L.C. diam. Core.
DOLOMITE	" " "	DIAMETRAL: 1.7- 4.8 MPa AXIAL : 8.3-13.8 MPa	" " " "
QUARTZITE	PETROLOGICAL DESC.	QUARTZ 55 - 95% FELDSPARS 5 - 45% OPAQUES) SERICITE) Traces only CHLORITE)	Quartzite to Metamorphosed arkosic sandstone
DOLOMITE	" "	DOLOMITE 90 - 95% QUARTZ 3 - 6% OPAQUES 2 - 4%	Foliated with Schistose texture (Referred to in text as phyllitic dolomite).
QUARTZITE	∅ Shear test	45° - 69° ≠	≠ Measured on plane dipping 22° into proposed Quarry.
DOLOMITE	" "	25° - 30° §	§ Measured along bedding plane in moderately weathered and highly weathered.

TABLE 22 Summary of Physical Properties

TABLE 23

LITTLE PARA DAM SITE - QUARRY TEST
 RELATIONSHIP BETWEEN DRILLING TIME AND POINT LOAD TEST

Drill Hole No.	Drill Interval metres	Drill Rate m/hr.	Rock Type / Comments	Point Load Test *		Strength Designation	Unconfined Compressive Strength Test. MPa
				MN/m ² Axial	MN/m ² f Diametral		
1	0 - 0.6	34	Surface Rubble				
	0.6 - 3.0	40	Weathered dolomite				
	3.0 - 5.3	15)				
	5.3 - 6.0	6) Rods Jamming				
	6.1 - 7.9	-)				
	7.9 - 9.1	31	Moderately weathered dolomite				31
	9.1 - 10.7	35	" " "				
	10.7 - 12.2	31	" " "				
	12.2 - 13.4	24	" " "	7		Very High	30 (57 where siliceous).
13.4 - 14.4	27	" " "		2.2	High		
2	0 - 1.2	25	" " "				
	1.2 - 3.0	34	" " "				
	3.0 - 4.3	40	Soft weathered dolomite				
	4.3 - 4.9	29	Weathered dolomite				
	4.9 - 5.8	44	" "		2.0	High	
	5.8 - 6.5	78	highly weathered dolomite seam				
	6.5 - 6.7	10	Quartzite		6.4 † o	Very high	90 - 290
	6.7 - 7.6	21	Flaggy Quartzite		0.5 †	Medium	
	7.6 - 9.1	16	Rods Sticking				
9.1 - 12.2	37	-					
12.2 - 15.2	26	Slightly weathered dolomite	5.0		Very high	30.0 (105 where siliceous)	
3	0 - 1.2	58	Surface Rubble				
	1.2 - 2.7	46	Highly weathered dolomite				
	2.7 - 3.0	27) Flaggy		1.8 †		
	3.0 - 5.8	21) Quartzite		2.4	High	
	5.8 - 9.1	21)				
	9.1 - 10.1	43	Weathered Dolomite		1.3	High	
	10.1 - 12.1	20)Rods				
12.1 - 13.7	11)Jamming					

* Reference to E. Broch and J.A. Franklin
 Drilling done by air track drill using a 76 mm bit.
 Point load tests carried out on core from nearby earlier test holes in quarry area.

‡ True diametral fracture very difficult to achieve
 † Fracture along cleavage/bedding plane
 ‡ Part fracture along cleavage/bedding plane
 o Quartzite gave extremely high readings and damaged equipment. New dial required.

TABLE 24

ROCKFILL AND CONCRETE AGGREGATE - LABORATORY TESTS

TEST	QUARTZITE		SILICIOUS DOLOMITE		COMENTS
	40 mm	20 mm	40 mm	20 mm	
LOS ANGELES ABRASION TEST (% weight loss)	21%	19%	21%	18%	Considered very resistant to abrasion.
AGGREGATE CRUSHING VALUE (% weight loss)	Insufficient material	18%	19%	19%	Considered hard material.
FLAKINESS INDEX	22%	24%	36%	36%	Australian Standard A.S. 1141 - recommended value less than 35.
ELONGATION INDEX	43	64	34	47	A.S. 1141 - recommended value less than 35.
SODIUM SULPHATE SOLUTION (% weight loss)	0.2%		6.5%		12% loss considered unacceptable
PHYLLITIC DOLOMITE ACCELERATED WEATHERING TEST	PRIOR TO CYCLES		FOLLOWING 10 CYCLES		≠ Zone 3 material Department of Main Roads. (N.S.W.). Test using Sodium Chloride. Sieve analyses were carried out using sieve sizes 3/4, 3/8, 3/16, 7, 14, 25, 52, 100, 200. Some breakdown of the coarser material is shown, otherwise very little change following the weathering and compaction tests (modified Proctor).
	L.L.	26-27	L.L.	21-23	
	P.L.	14-15	P.L.	8-9	
	P.I.	12-13	P.I.	13-14	
	LINEAR SHRINKAGE	2-5	LINEAR SHRINKAGE	No Result	

SUMMARY - The carbonate of the dolomite is not affected to any great extent by the weak acid of the sulphate and chloride tests. Presence of silicates renders dolomite more resistant to abrasion but may however increase the flakiness.

TABLE 24 Rockfill and Concrete Aggregate-Laboratory Tests

TABLE 25

LITTLE PARA DAM

TESTING OF COMPLETELY WEATHERED DOLOMITIC SILTSTONE-RIGHT ABUTMENT

		SAMPLE 1	SAMPLE 2	SAMPLE 3
Moisture Content %		12	19	11
Liquid Limit		34	42	41
Plasticity Index (LL.-P.)	P.I. 20% is suspect	9	11	13
% passing .425 mm		99	93	93.5
Mech Analysis % passing .075 mm		81	63	65.5
% finer than 0.0005 mm	25% 0.0005 is suspect	17	14	13.5
% clay		11	9	9
Activity = $\frac{PI}{\% \text{ finer than } .0002}$	Corrected activity should be 0.6	0.82	1.29	1.44
* Some typical Activity values are:-		Values for the Activity Index fall within three main groups:		
Bentonite	7.2			
Calcium Montmorillonite	1.5			
Illite	0.9			
Kaolinite	0.3 - 0.5			
(Mica	0.23			
Clay Size (Calcite	0.18			
(Quartz	0			
			INACTIVE CLAY	0.75
			NORMAL CLAY	0.75 - 1.25
			ACTIVE CLAY	1.25

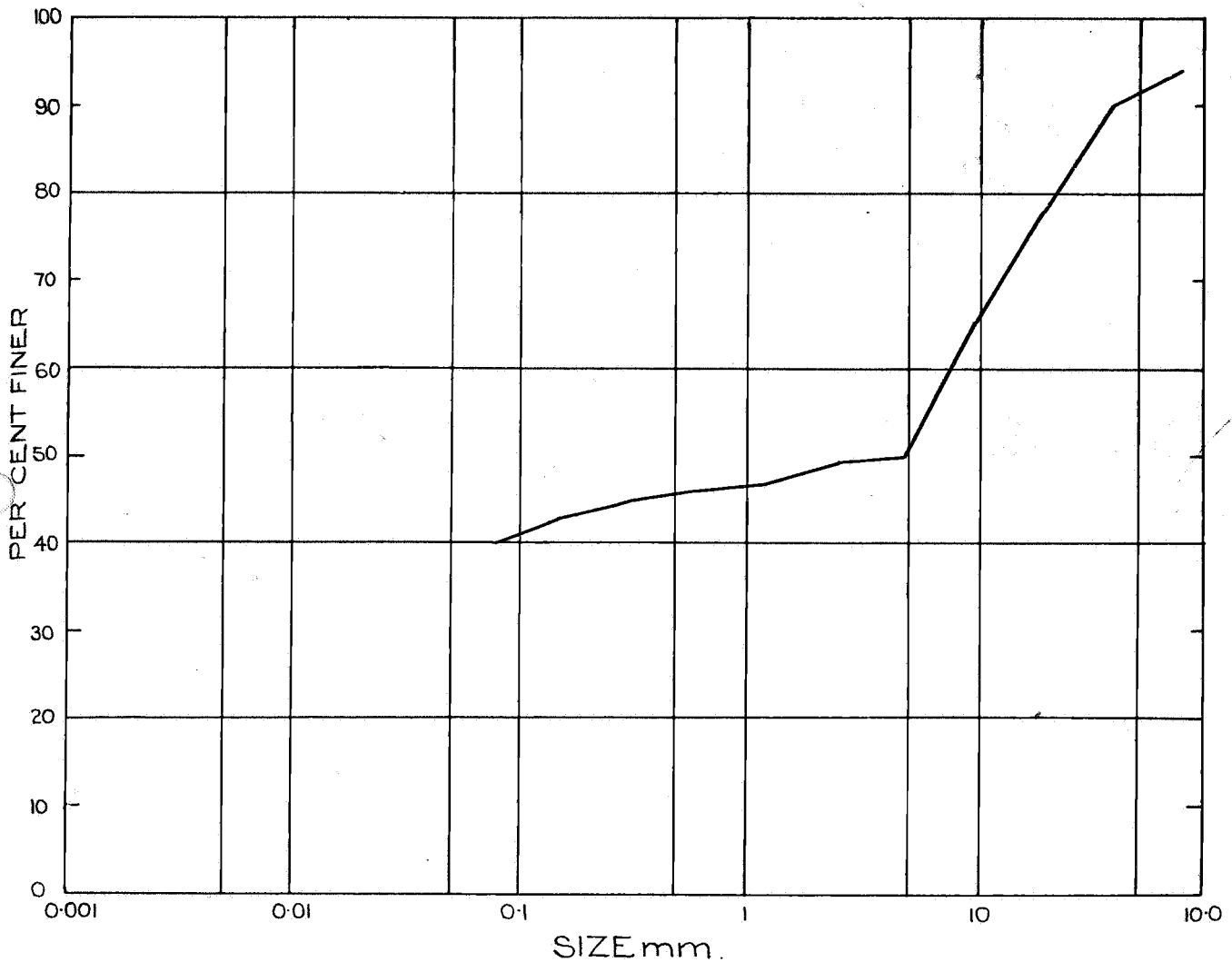
TABLE 25

TABLE 26

SUMMARY OF RING DENSITY TEST RESULTS

Zone	Date of Test	Elevation Tested EL	Test Material Analysis	Material Specified	Dry Density kg/m ³ (lb/ft ³)	Bulking Factor %	Compaction (No. of passes of 10T VIB. Roller)	% Fines Passing 26.5 mm Test Sample	28-67 Grading Envelope Specification	Remarks
1	27-2-76	112.0 to 111.0	QUARTZITE (medium weathered to weathered)	HARD DURABLE ROCK	1840 (115)	27.6	8 (min. of 4 specified)	47	28-67 Refer to FIG. 67 grading Envelope	Grading slightly out-side grading envelope on lower sizes. Material slightly on soft side. (L.A. Value is 40%).
2	24-3-76	112.0 to 111.0	QUARTZITE(Fresh) with traces of dolomitic shale in lower sizes and fines	HARD DURABLE ROCK	2150 (134.4)	18.5	8 (min. of 4 specified)	40	20	% fines (less than 26.5 mm) excessive. Sample not truly representative for Zone 2 to EL 112. High degree of contamination from adjacent Zone 3.*
4	26-3-76	110.0 to 109.0	QUARTZITE(Fresh, hard, some medium weathered) few shaley dolomite fines	HARD DURABLE ROCK	1973 (123.1)	25	8 (min. of 4 specified)	23.4	20	% Fines (less than 26.5 mm) slightly above specified limit.
6	27-3-76	110.0 to 109.2	SHALE & DOLOMITIC SHALE(Weathered to slightly weathered)	not specified, poorer quality rock acceptable.	1997 (124.6)	21.3	2 (2 specified)	26.7	40	Material and % Fines within specification.
1	1-7-76	125.0 to 124.5	SOUND QUARTZITE	HARD DURABLE ROCK	2116.5 (132.1)	4.9	8 (min. of 4 specified)	38	28-67 Refer to attached grading Envelope For Zone 1.	
3	9-6-76	121.0 to 120.0	SOUND SHALE, Dolomitic shale with some weathered dolomite.	HARD DURABLE ROCK	2010 (125.4)	17.9	8 (min. of 4 specified)	38	30	

* Top 0.5 m of Zone 2 layer was removed and replaced with clean fresh quartzite after the ring density test samples were taken.

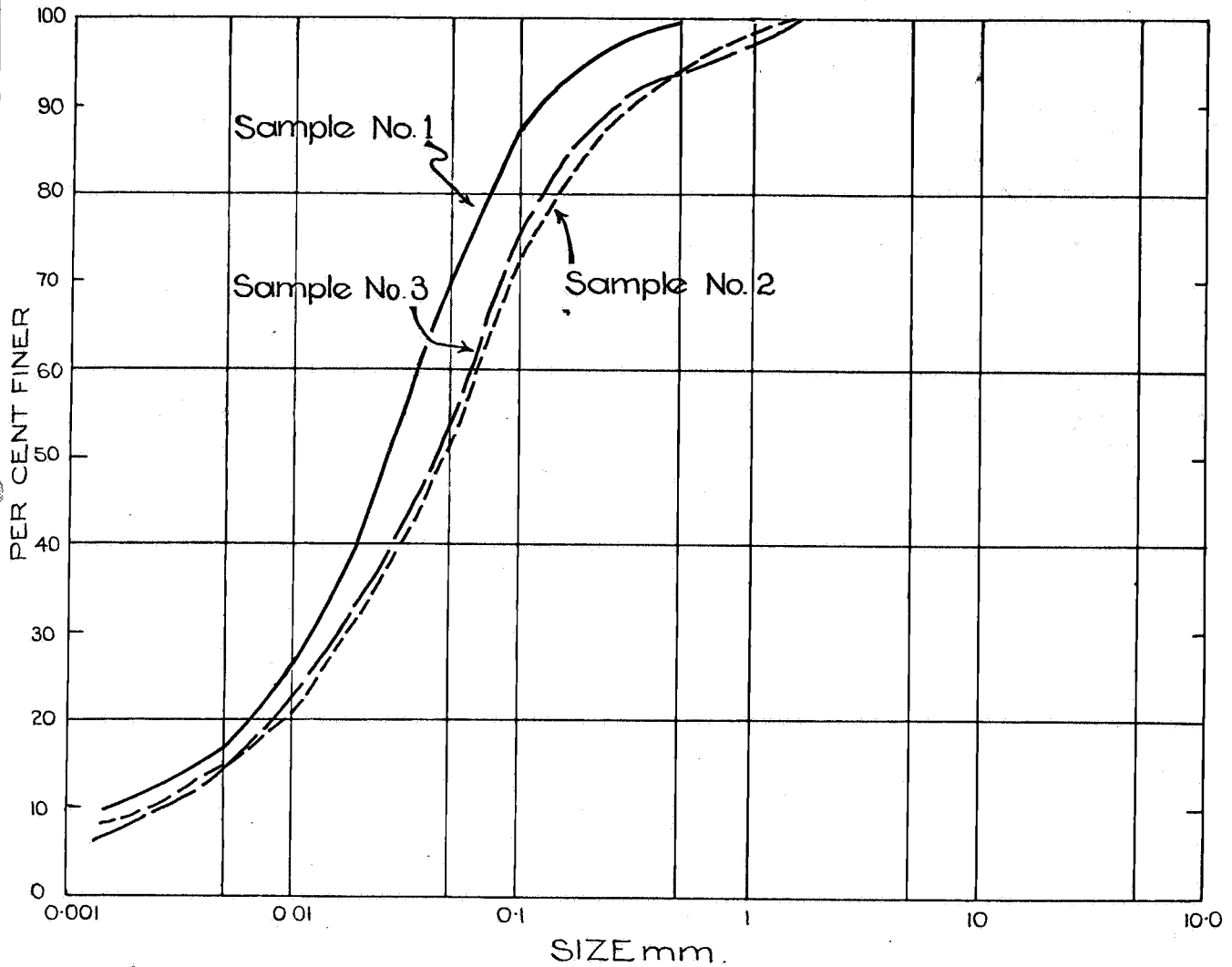


CLAY	Fine SILT	Medium SILT	Coarse SILT	Fine SAND	Medium SAND	Coarse SAND	GRAVEL
------	-----------	-------------	-------------	-----------	-------------	-------------	--------

Mechanical Analysis	% Passing	Mechanical Analysis	% Passing	Soil Test Constants
75 mm.		9.5 mm. (3/16")	56	LL. 46.4 PL. 13.7 PI. 32.7 LINEAL SHRINKAGE 8.7% COMPACTION TEST Mod. A.A.S.H.O. O.M.C. 11.5% D.D. 120
63 mm.	96	6.7 mm. (No.7)	49	
53 mm.	90	4.75 mm. (No.14)	47	
37.5 mm.	84	2.36 mm. (No.25)	46	
26.5 mm.	78	1.18 mm. (No.52)	45	
19 mm.	71	600 μm. (No.100)	43	
16 mm.	65	425 μm. (No.200)	40	
13.2 mm.	56			

Fig. 64

ENGINEERING GEOLOGY SECTION	DEPARTMENT OF MINES — SOUTH AUSTRALIA	Scale :
Compiled J.C.B.	LITTLE PARA DAM MECHANICAL ANALYSIS— SOIL ROAD FILL	Date : 15-1-76
Drn J.W. Ckd		Drg. No.
		SI2069

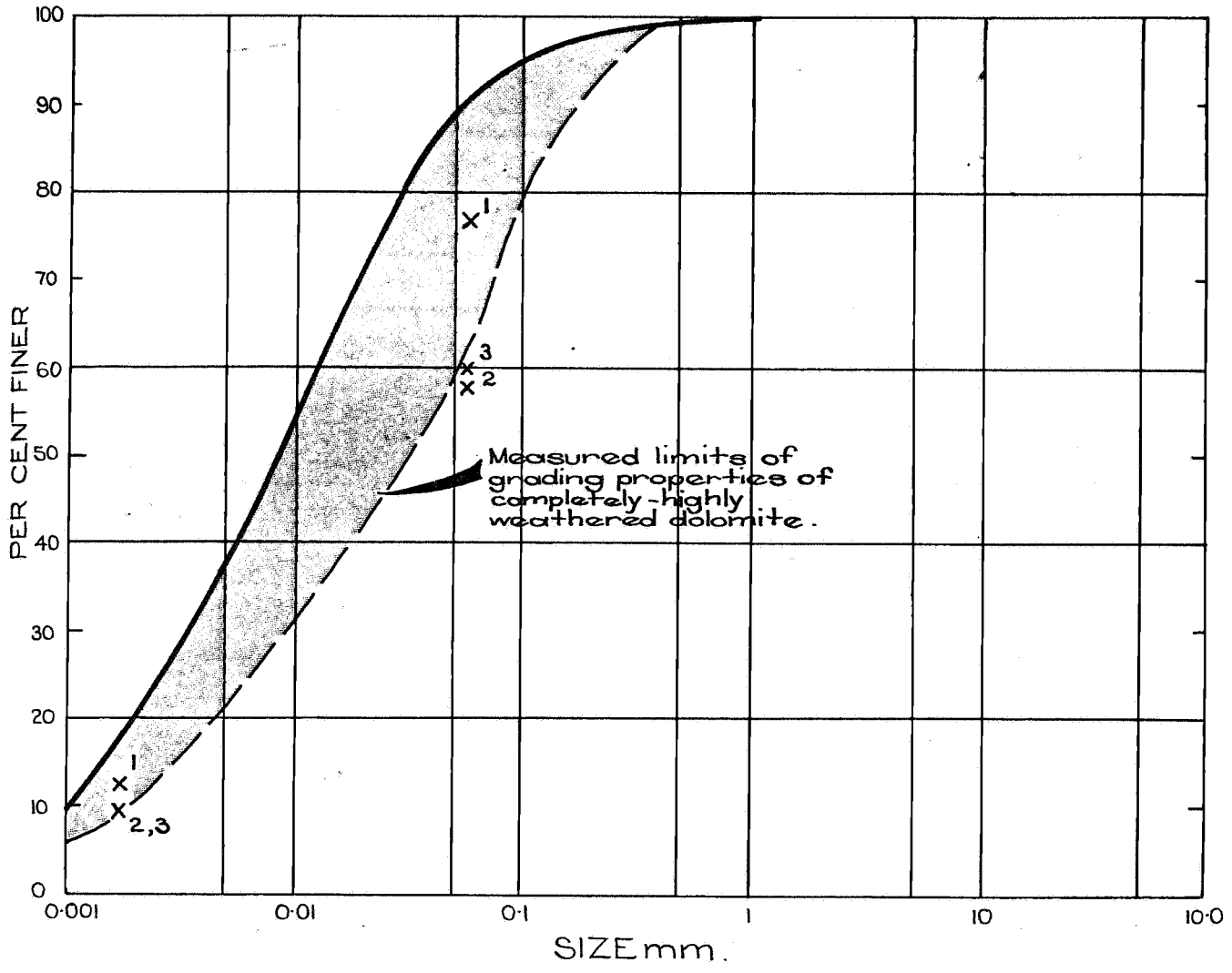


CLAY	Fine	Medium	Coarse	Fine	Medium	Coarse	GRAVEL
	SILT			SAND			

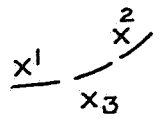
Sample	Depth	Description	Line	M.C. %	Lime Cont.	Hydrometer			Sand Fraction				
						Clay	Silt	Sand	-200	Fine	Med.	Coarse	Gravel
SPL.1		Decomposed Rock		12		11	64	25		20	5	-	
SPL.2		"		19		9	47	44		29	11	4	
SPL.3		"		11		9	49	42		29	8	5	

Date tested - 23-8-75
 Mechanical Analysis - Weathered dolomitic siltstone Fig. 65

ENGINEERING GEOLOGY SECTION	DEPARTMENT OF MINES — SOUTH AUSTRALIA	Scale :
Compiled J.C.B.	LITTLE PARA DAM	Date : 15-1-76
Drn J.W. Ckd	MECHANICAL ANALYSIS OF ROCK SAMPLES FROM INSPECTION TRENCH ON RIGHT ABUTMENT	Drg. No. SI2068



CLAY	Fine	Medium	Coarse	Fine	Medium	Coarse	GRAVEL
	SILT			SAND			



Samples taken from parapet wall trench at top of right bank grout cap blocks T & U.

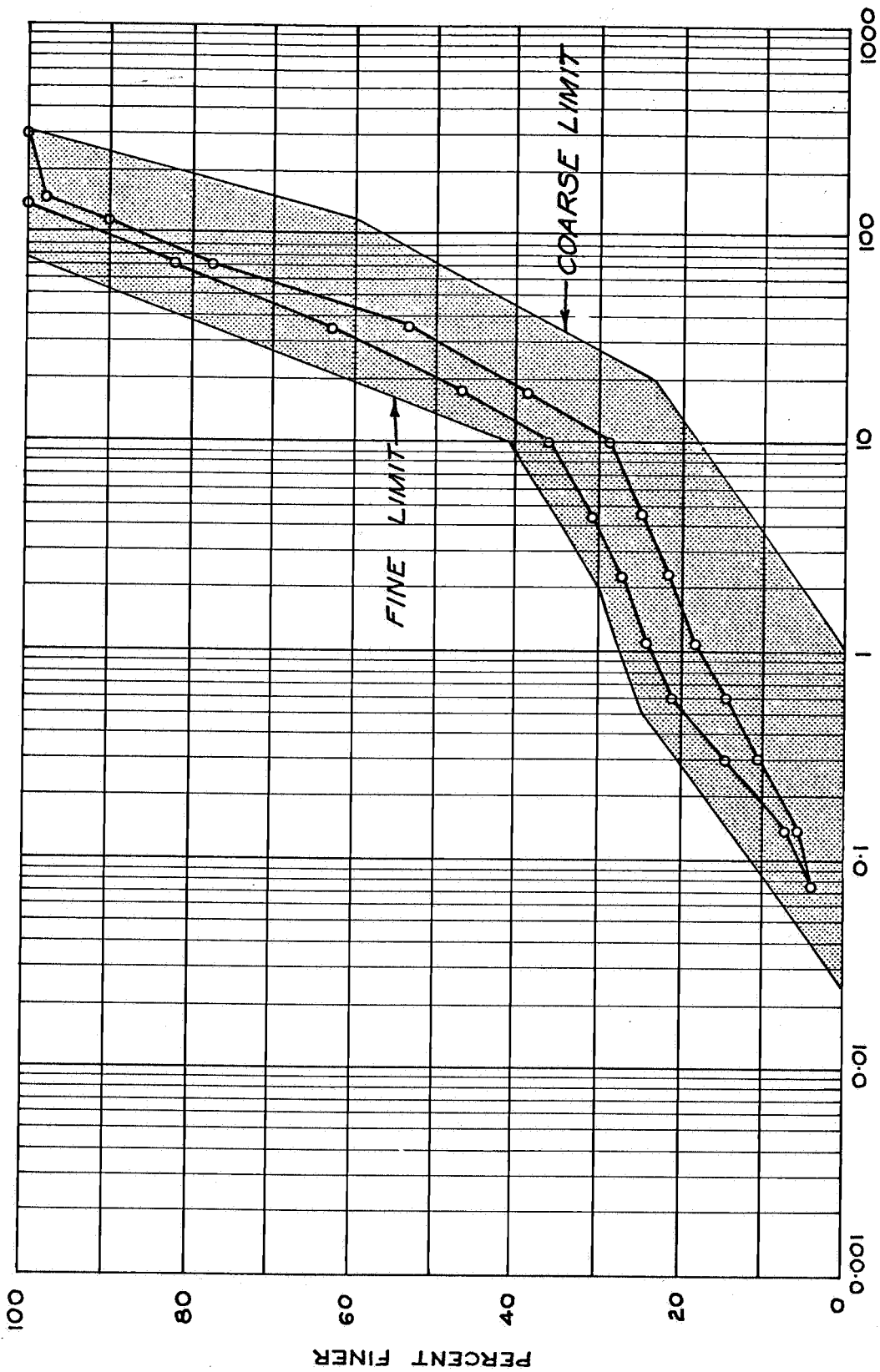


Sample taken from weathered dolomitic siltstone seam associated with stress relief fracture towards base of BLOCK E, left bank grout cap.

Date tested : 11-3-75
FIG. 66

ENGINEERING GEOLOGY SECTION	DEPARTMENT OF MINES — SOUTH AUSTRALIA	Scale :
Compiled : J.C.B.	LITTLE PARA DAM RIGHT AND LEFT BANK GROUT CAPS MECHANICAL ANALYSIS- WEATHERED DOLOMITIC SILTSTONE	Date : 15-1-76
Drn. J.W. Ckd :		Drp. No. S12067

1126



○ Grading curves
 [shaded area] ZONE 1 Grading Envelope

DATA FROM ADDITIONAL LABORATORY TESTING	
Wet Density = 1,170 lb/ft ³	Porosity, N = 27.3%
M/C = 1.7%	Appt. S G = 2.55
Dry Density = 1,150 lb/ft ³	

Fig. 67

ENGINEERING SERVICES	DEPARTMENT OF MINES - SOUTH AUSTRALIA	SCALE GRAPHICAL
COMPILED: J.C. BEAL	LITTLE PARA DAM	DATE: 26 TH APRIL 1977
DRN: CKD.	RING DENSITY TEST N ^o 2	PLAN NUMBER
	ZONE 1 (EL 112.0)	SI2680

1126

PETROLOGICAL DESCRIPTION OF FIVE ROCK SAMPLES
 FROM LITTLE PARA DAM AND THEIR ASSESSMENT
 FOR USE AS CONCRETE AGGREGATE.
 REPORT BY AUSTRALIAN MINERAL
 DEVELOPMENT LABORATORIES, ADELAIDE. S.A.

Sample: P384/74, TS33034

Rock Name:

Carbonate bearing mica schist.

Hand Specimen:

Beige coloured schistose meta siltstone.

Thin Section:

An optical estimate of the constituents gives the following:

	<u>%</u>
Quartz	30-35
Feldspars	5
Muscovite and other Phyllosilicates	20
Carbonate	40
Opauques	1
Biotite	Trace

This sample represents a carbonate-bearing siltstone which has undergone greenschist facies regional metamorphism.

The rock is most probably unsuitable for use in concrete aggregate because it contains dolomite and phyllosilicates.

Independent whole rock X.R.D. analysis indicated the following minerals and proportions.

Dolomite	D	(Dominant)
Quartz	SD	(Sub-dominant)
Muscovite	SD	
Biotite or similar	SD	
Feldspar (Albitic)	A	(Accessory)
Chlorite	A	
K-Feldspar	Tr	(Trace)

Sample: P385/74, TS33035

Rock Name:

Feldspathic quartzite

Hand Specimen:

Fine grained, well sorted quartzitic feldspar bearing rock.

Thin Section:

An optical estimate of the constituents gives the following:

	<u>%</u>
Quartz	75
K-Feldspar	20-25
Lithic fragments	2
Plagioclase	1
Opaques	trace
Muscovite	trace
Zircon	trace

The rock would most probably be suitable for use in concrete aggregate as it does not contain abundant phyllosilicates, dolomite or reactive forms of silica.

Sample: P386/74, TS33036

Rock Name:

Feldspathic quartzite

Hand Specimen:

Fine grained, well sorted, weakly bedded feldspar-bearing quartzitic rock containing minor muscovite.

Thin Section:

An optical estimate of the constituents gives the following:

	<u>%</u>
Quartz	70-75
K-Feldspar	15-20
Lithic fragments	1-2 (Quartz-feldspar)
Plagioclase	1-2
Muscovite	3-5
Opaques	1-2
Carbonate (?)	1-3
Zircon, Sphene, rutile	trace

The rock is clearly suitable for use in concrete aggregate as it does not contain reactive silica, phyllosilicates, dolomite

or pyrite (the last mineral causes cosmetic problems due to secondary iron staining).

Sample: P387/74, TS33037

Rock Name:

Weakly metamorphosed siltstone.

Hand Specimen:

Grey green schistose metasiltstone.

Thin Section:

An optical estimate of the constituents gives the following:

	<u>%</u>
Quartz	55-60
Feldspars	5
Muscovite and other Phyllosilicates	
Carbonate	1-2
Opagues	1-2

Texturally and mineralogically this rock closely resembles sample P384/74; however, carbonate is much less abundant and there is less evidence of recrystallization. Petrographic evidence suggests that the rock would not be suitable for use in concrete aggregate for the earlier mentioned reasons. Independent whole rock X.R.D. analysis indicated the following minerals and proportions.

Quartz	D
Muscovite	SD
Plagioclase (albitic)	A
Chlorite	A
(?) Biotite or similar	A
K-Feldspar	Tr

SUMMARY

<u>Sample</u>		<u>Suitability for use in concrete Aggregate</u>
P384/74	Carbonate-bearing mica schist	Unsuitable
P385/74	Feldspathic quartzite	Suitable
P386/74	Feldspathic quartzite	Suitable
P386/74	Feldspathic quartzite	Suitable
P387/74	Meta-siltstone	Unsuitable

PHYSICAL TESTS ON SAMPLES OF COMPLETELY WEATHERED
DOLOMITIC, SILTSTONE, RIGHT BANK GROUT CAP EXCAVATION,
LITTLE PARA DAM.

REPORT BY SOILS AND FOUNDATIONS LABORATORY NETLEY,
ENGINEERING AND WATER SUPPLY DEPARTMENT

Engineers on the site requested that the decomposed rock found in the excavation for the grout cap at the top of the right abutment be tested and the following properties ascertained.

1. Grading and dispersion properties
2. Atterberg limits
3. Permeability

This information is to be used to determine the likely behaviour of this material when subjected to the head at full storage level of the reservoir.

Three tube samples were taken of soft decomposed dolomitic siltstone underlying a quartzite stratum and all samples were taken from the downstream face of the trench. In addition bag samples of this material was taken. The trench was later infilled with concrete and served as the footing for the parapet wall.

In situ the material appeared to vary over the depth of the deposit. Most apparent variations were in the moisture content, suggesting possible local water paths, and also the brittleness. In places the material was very fractured and could easily be broken into small, strong rectangular prisms. The three sub types ie. normal, higher M.C.%, fractured, were all sampled and it was attempted to quantify the relative permeabilities in the laboratory.

RESULTS

The following results have been obtained from standard laboratory testing procedure on the material sampled:-

SAMPLE	M.C. %	SAND %	SILT %	CLAY %	L.L. %	P.L. %	k(perm) m/sec.	HT OF SAMPLE (mm)	HEAD WATER (mm)
1.	12	20(f) 5(m)	64	11	34	25	5.57×10^{-7}	100	1530
2.	19	29(f) 11(m) 4(c)	47	9	42	31	*	100	-
3.	11	29(f) 8(m) 5(c)	49	9	41	28	8.28×10^{-6}	65	1630

f = fine m = medium c = coarse

A clay dispersion test was done. This gave a negative result, ie. no dispersion of fine material was noticed.

Comment on Permeability Values

The permeability test was carried out on the actual tube samples as taken in the field, ie. no sub-sampling was necessary. This avoided any further disturbance to the material. Even so, some disturbance when jacking the samples in the field is unavoidable and in this case because of the presence of layers of very friable material is likely to cause significant increases in the permeability value as obtained from the laboratory test.

In all the tests the operator noticed an early rush of water through the sample which then slowed as a steady state flow was achieved. After the test was completed the samples were broken up and it was noticed that there had been a transportation of the fine particles through the sample. In sample 1 these particles were deposited on a fissure at right angles to the direction of flow. In sample 3 the fine particles migrated through the entire sample. Sample 1 probably gave the only realistic answer.

In samples 2 and 3 the operator noticed water passing through three or four small holes as well as around the edges of the sample. The hole in sample 3 was approx. 3-6 mm \emptyset and no sensible result could be obtained.

It would be dangerous to disregard these samples altogether as the layers of very friable material break off prismoidally and constitute easy access paths for the water. However, the disturbance associated with sampling will have contributed to the high leakage between the sample and the tube. To get the affect of these causes into perspective is mostly intuitive.

Therefore, it is suggested that a permeability of 5×10^{-7} m/sec be used.

This result is similar to one obtained previously when other tests on similar material obtained from the upstream part of the abutment were done.

The confidence level which can be assigned to the above given value of permeability must be low (2 test results). If a decision, based on this result, involves expensive remedial work, it may be advisable to arrange for more tests to be done.

ASSISTANT DESIGNING ENGINEER
SOILS AND FOUNDATIONS

APPENDIX 5
REFERENCE DATA
THE LUGEON TEST
DEFINITION OF ROCK TERMS
DEFINITION OF PERMEABILITY
THE UNIFIED SOIL CLASSIFICATION SYSTEM

THE LUGEON TEST

The Lugeon Unit

1 lugeon unit is defined as a water take of 1 litre per metre of test hole length per minute at 10 bars (1 000 KPa or 150 p.s.i.) and is very approximately equal in value with 10 ft/year of 1.2×10^{-5} cm/second.

1 lugeon is the degree of permeability encountered in those nearly tight foundations which require almost no grouting at all.

3 lugeons represent a foundation where some grouting may be required, if the dam is to be a concrete one, or where the water is so precious, or piping is very possible, that all seepage must be stopped.

5 lugeons warrants extensive grouting for a concrete dam, or light grouting for some earth rockfill ones.

10 lugeons warrants grouting for most types of dams.

20 lugeons is typical of heavily jointed sites with relatively small joint openings.

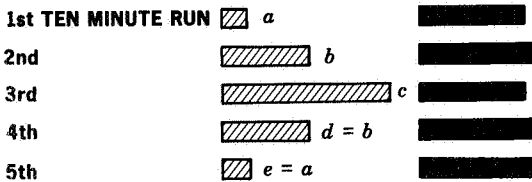
100 lugeons is encountered in heavily jointed sites with relatively open joints. It is also met in sparsely cracked foundations where joints are very wide open.

100 lugeons represents the upper limit of reasonableness
Taken from A.C. Houlsby (1976).

INTERPRETATION OF WATER LOSSES

TEST PRESSURES <small>(SHOWN IN APPROXIMATE RELATIVE MAGNITUDE)</small>	LUGEON PATTERN LUGEONS CALCULATED FOR EACH 10 MINUTE RUN* <small>(RELATIVE MAGNITUDES SHOWN IN GENERALISED PATTERNS. ACTUAL MAGNITUDES CAN VARY WIDELY)</small>	CHARACTERISTICS OF THE PATTERN, AND INTERPRETATION	WHICH OF THE LUGEON VALUES IN THE PATTERN SHOULD BE USED AS THE REPORTED PERMEABILITY ?	PERCENTAGE OF ACTUAL CASE HISTORIES STUDIED <small>WHEN THE REPORTED PERMEABILITY IS 1, 2 OR 3 LUGEONS 4 OR MORE LUGEONS</small>
--	--	--	---	---

GROUP A - LAMINAR FLOW



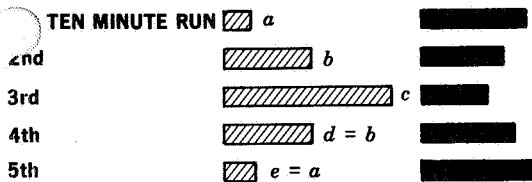
ALL 5 LUGEONS ARE ABOUT EQUAL HENCE LAMINAR FLOW

USE THE AVERAGE OF THE FIVE LUGEONS
(TO THE NEAREST WHOLE NUMBER)

78%

5%

GROUP B - TURBULENT FLOW



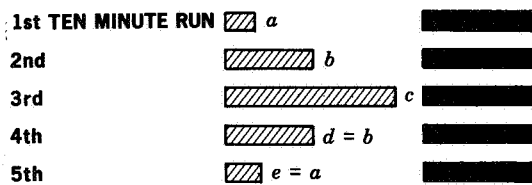
LOWEST LUGEON VALUE OCCURRING AT HIGHEST PRESSURE HENCE TURBULENT FLOW

USE THE LUGEON VALUE FOR THE HIGHEST PRESSURE

13%

53%

GROUP C - DILATION



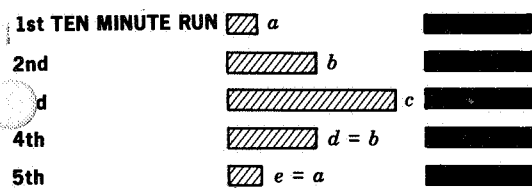
HIGHEST LUGEON OCCURRING AT HIGHEST PRESSURE HENCE DILATION

USE THE LUGEON VALUE FOR THE LOWEST (OR MEDIUM) PRESSURES

1%

9%

GROUP D - WASH-OUT



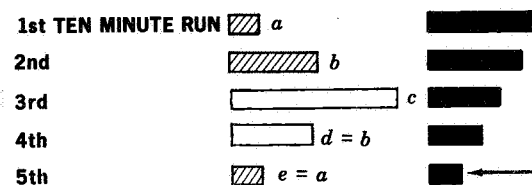
LUGEONS INCREASING AS TEST PROCEEDS HENCE THE TEST IS CAUSING CHANGES TO THE FOUNDATION

USE THE HIGHEST LUGEON VALUE UNLESS SPECIAL REASONS REQUIRE OTHERWISE

2%

21%

GROUP E - VOID FILLING



LUGEONS DECREASING AS TEST PROCEEDS HENCE THE TEST IS GRADUALLY FILLING EXTENSIVE VOIDS

USUALLY USE THE FINAL LUGEON VALUE

6%

12%

* CALCULATED USING DIRECT PROPORTION TO RELATE TO LUGEON'S 'DEFINITION' PRESSURE OF 10 BARS (150 p.s.f.)

THIS TABLE GIVES GENERAL PATTERNS ONLY. DISCRETION IS NECESSARY IN ADAPTING THESE TO THE INEVITABLE VARIATIONS MET IN PRACTICE.

Lugeon Patterns for Various Occurrences During Testing - Their Interpretation and Percentage Occurrences.

DEFINITION OF ROCK TERMS

1. ROCK CONDITION		
TERM	ABBRN	DEFINITION
Fresh	(F)	No weathering effects visible to naked eye.
Weathered	(W)	Shows visible effects of chemical decomposition caused by air and groundwater. Can be subdivided:
Slightly weathered	(SW)	- change in appearance but no loss in strength
Moderately weathered	(MW)	- change in appearance but with significant loss in strength
Completely weathered	(CW)	- has soil properties and often shows complete change in appearance
Altered	(A)	Shows chemical and physical alteration to rock fabric caused by temperature, pressure or injection of other material.

2. ROCK STRENGTH			
TERM	ABBRN	Kg cm ² (p.s.i.)	FIELD TEST
Very Weak	VW	70 (1 000)	Breaks and crumbles easily in the hands.
Weak	W	70-200 (1 000-3 000)	Breaks easily with hammer tap.
Medium strong	MS	200-700 (3 000-10 000)	Rings and breaks to firm hammer blow.
Strong	S	700-1 800 (10 000-25 000)	(Very difficult to break with hammer (and requires sledge
Very strong	VS	>1 800 (>25 000)	(

DEFINITION OF ROCK TERMS AFTER DEPT. OF MINES AND ENERGY

CLASSIFICATION AFTER BROCK AND FRANKLIN			DEPT. OF MINES & ENERGY CLASSIFICATION	
Rock strength class.	Point Load strength Index	Approximate compressive strength.	Term.	Field Test.
	Is (50) MPA	Qu MPA. Quartzite range.		
Extremely low				Breaks and crumbles easily in the hands.
	0.03	0.7	Very weak.	
Very low				
	0.1	2.4		
low				
	0.3	7		
medium			Medium	Broken with hammer tap
	1	24	Medium strong	Rings and breaks to firm hammer blow.
High				
	3	70		
Very high			Strong	difficult to break
	10	240	Very strong	requires sledge to break.
Extremely high				

Term	Point load strength (kN/m ² = 145 x 10 ⁻³ lb/in ²)	Compressive strength MN/m ² (1MN/m ² = 145 lb/in ²)
Extremely strong	>12000	>200
Very strong	6000-12000	100-200
Strong	3000- 6000	50-100
Moderately strong	750- 3000	12.5- 50
Moderately weak	300- 750	5- 12.5
Weak	75- 300	1.25- 5
Very weak	<75	<1.25

ROCK STRENGTH CLASSIFICATION AFTER GEOLOGICAL SOCIETY ENGINEERING GROUP WORKING PARTY (REF: Q.J. ENNG. GEOL. VOL. 5 NO. 4 1972).

DEFINITION OF PERMEABILITY

Soil description	Term	Permeability value k in m/s units
Clean gravels	Highly permeable	10^{-2} - 1
Clean sands, sandy gravels and gravelly sands	Moderately permeable	10^{-5} - 10^{-2}
Fine sands, silts, some weathered clay	Slightly permeable	10^{-9} - 10^{-5}
Clays	Effectively impermeable	$\approx 10^{-9}$

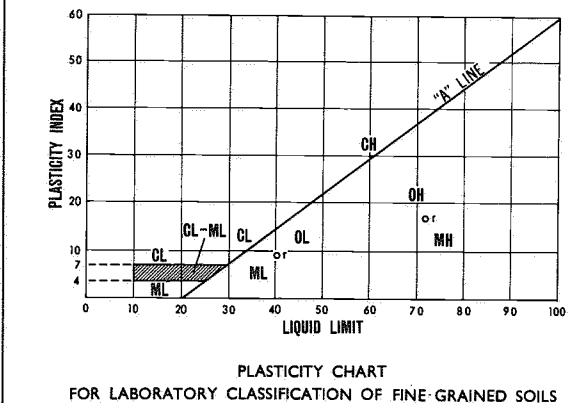
Rock mass description	Term	Permeability value k in m/s units
Very closely to ex- tremely closely spaced joints	Highly permeable	10^{-2} - 1
Closely to moder- ately widely spaced joints	Moderately permeable	10^{-5} - 10^{-2}
Widely to very widely spaced joints	Slightly permeable	10^{-9} - 10^{-5}
Unjointed, solid	Effectively impermeable	$< 10^{-9}$

PERMEABILITY VALUE CLASSIFICATION AFTER GEOL. SOC. ENGG. GROUP WORKING
PARTY.

(Ref: Q.J. Engng. Geol. Vol. 5 No. 4 1972).

DEPARTMENT OF MINES - SOUTH AUSTRALIA
ENGINEERING CLASSIFICATION OF SOILS
 The Unified Soil Classification System

COARSE-GRAINED SOILS More than 50% of material is larger than No. 200 B.S. sieve size	FIELD INVESTIGATION PROCEDURES Excluding particles larger than 7.5cm and basing fractions on estimated weights						GROUP SYMBOL	GROUP NAME and typical materials	LABORATORY CLASSIFICATION CRITERIA				
	GRAVELS More than 50% of the coarse fraction is larger than 2mm. (retained on B.S.7 sieve)	CLEAN GRAVELS Little or no fines	Wide range in grain sizes, and substantial amounts of all intermediate particle sizes								GW	GRAVEL, well graded; gravel sand mixtures, little or no fines	$C_u = \frac{D_{60}}{D_{30}} \geq \frac{D_{10}}{D_{60}}$ Greater than 4 $C_c = \frac{D_{30}^2}{D_{10} \times D_{60}}$ Between 1 and 3 Not meeting all gradation requirements for GW Atterberg limits below "A" line or PI less than 4 Atterberg limits above "A" line or PI greater than 7 $C_u = \frac{D_{60}}{D_{30}} \geq \frac{D_{10}}{D_{60}}$ Greater than 6 $C_c = \frac{D_{30}^2}{D_{10} \times D_{60}}$ Between 1 and 3 Not meeting all gradation requirements for SW Atterberg limits below "A" line or PI less than 4 Atterberg limits above "A" line or PI greater than 7
FINE-GRAINED SOILS More than 50% of material is smaller than No. 200 B.S. sieve size	SANDS More than 50% of the coarse fraction is smaller than 2mm. (passing B.S.7 sieve)	CLEAN SANDS Little or no fines	Wide range in grain sizes, and substantial amounts of all intermediate particle sizes				SW	SAND, well graded; well graded sands, gravelly sands, little or no fines	GRAIN SIZE CURVES to be used to identify soil fractions	PERCENT OF FINES GRAVELS SANDS Less than 5 GW GP More than 12 GM GC 5 to 12 Borderline cases, use 2 symbols	Coarse-grained soil classified on basis of percentage of fines, as follows Atterberg limits below "A" line or PI less than 4 Atterberg limits above "A" line or PI greater than 7 Above "A" line with PI between 4 and 7 are borderline cases requiring use of dual symbols		
			Predominantly one size or a range of sizes, with some intermediate sizes missing				SP	SAND, poorly graded; poorly graded sands, gravelly sands, little or no fines					
		DIRTY SANDS Appreciable amount of fines	Non-plastic fines—for identification see ML below				SM	SAND, excess silty fines; poorly graded sand-silt mixtures					
			Plastic fines—for identification see CL below				SC	SAND, excess clayey fines; poorly graded sand-clay mixtures					
			FIELD INVESTIGATION PROCEDURES on fraction smaller than 0.4mm. (passing B.S. 36 sieve)									GROUP SYMBOL	GROUP NAME and typical materials
			SILTS AND CLAYS Liquid limit less than 50	SOIL CAST (soil wet)	SOIL THREAD	SHINE	DILATANCY	ODOUR					
	Forms fragile cast Cracks form when kneaded while moist	Thick crumbly thread; easily broken		None to very dull	Distinct	Not significant	None to slight	CL				CLAY SOIL, low plasticity; inorganic clays of low to medium plasticity, gravelly clay, sand, clays, silty clays, lean clays	
	SILTS AND CLAYS Liquid limit more than 50	Cast maybe handled freely without breaking Can be kneaded moist without cracking Material adheres to the hand	Thread can be pointed as fine as a lead pencil but is fragile	Moderate	None to slight	Not significant	Moderate	OL				ORGANIC SOIL, low plasticity; organic silts and silt clays of low plasticity	
		Cast fragile to cohesive material will adhere somewhat to the hand	Soft, weak thread	None to very dull	Slight to distinct	Decayed organic matter	Low	MH				SILT SOIL, high plasticity; inorganic silts, micaceous or diatomaceous fine sandy or silty soils, elastic silts	
		Moderately plastic and cohesive Material adheres somewhat to the hand	Weak to medium thread May be crumbly	Dull	None to slight	Not significant	Moderate Powdered soil feels floury	CH				CLAY SOIL, high plasticity; inorganic clays of high plasticity, fat clays	
		Very plastic and cohesive Material very sticky to the hand Greasy to touch	Very tough thread, can be rolled to a pin point	Very glossy	None	Strong earthy	High to very high Cannot be powdered by finger pressure	OH				ORGANIC SOIL, high plasticity; organic clays of medium to high plasticity	
	SILTS AND CLAYS Liquid limit more than 50	Plastic and cohesive Feels slightly spongy Greasy to touch	Weak to medium thread Often soft and fibrous	Moderate to very glossy	None	Decayed organic matter	Moderate to high Powdered soil may be fibrous	PT				PEATY SOIL; Peat and other highly organic soils	
Readily identified by colour, odour, spongy feel and frequently by fibrous texture													



NOTE: BOUNDARY CLASSIFICATIONS: Soil possessing characteristics of two groups are shown as a combination of two group symbols, eg. GW-GC, well graded gravel with clay binder.

Based on "The Unified Soil Classification System" United States Department of the Interior, Bureau of Reclamation "Earth Manual" First Edition, Denver COLORADO 1960. S.A. Dept. of Mines